



FD3S Turbo Manifold

Rev.1 - Oct 8, 2015



Overview

This manifold came to life after seeing cheap, low quality manifolds pass through the RX7 community time and time again. No thought into wastegate priority, thin wall tubing construction, and laser cut mild steel flanges. These products would either leak, crack, or most commonly, boost creep. The exhaust temperatures and flow from a Rotary engine demand a better product.

Our new long runner twin scroll FD3S manifold is a solution to those problems. Billet CNC 304 stainless flanges, thick wall sch40 primaries (0.109" Thick), precision tig welding process that's fully back purged, and wastegate positions that are intentionally tear dropped directly into the path of exhaust flow.

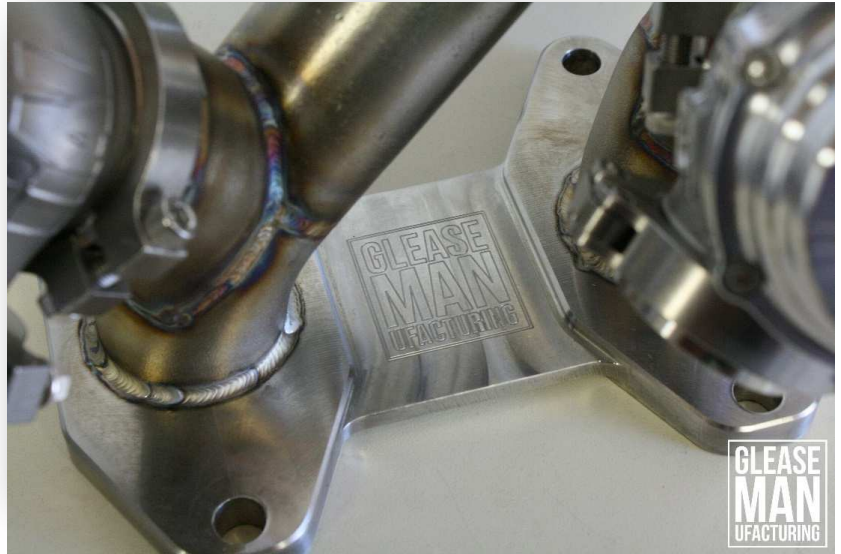

***** The Ultimate FD Turbo Manifold is now available.*****



Construction

All of our flanges are CNC machined from half inch billet 304 stainless. **Often builders will choose mild steel and basic laser cutting for cost effectiveness and ease of fabrication, but we don't.** This allows us to accurately and consistently match the exact shape of the rotor housing, and perfectly taper it to the dimension of the primaries. This means no hand porting what so ever, and perfectly matched ports on the front and rear.



The last step of building these manifolds is sanding the flanges perfectly flat. This is time consuming to do properly on 304 stainless, but it's a critical step for a perfect seal and crack resistance. Torqueing an untrue manifold to an engine block will stress the primaries, and often results in cracking.

We have never had a manifold leak or crack.



Our wastegate positions are crucial. This keeps from over-boosting at lower boost levels, and makes boost control smooth and predictable. The entries are tear dropped, which allows a larger, more directional flow into the wastegates.

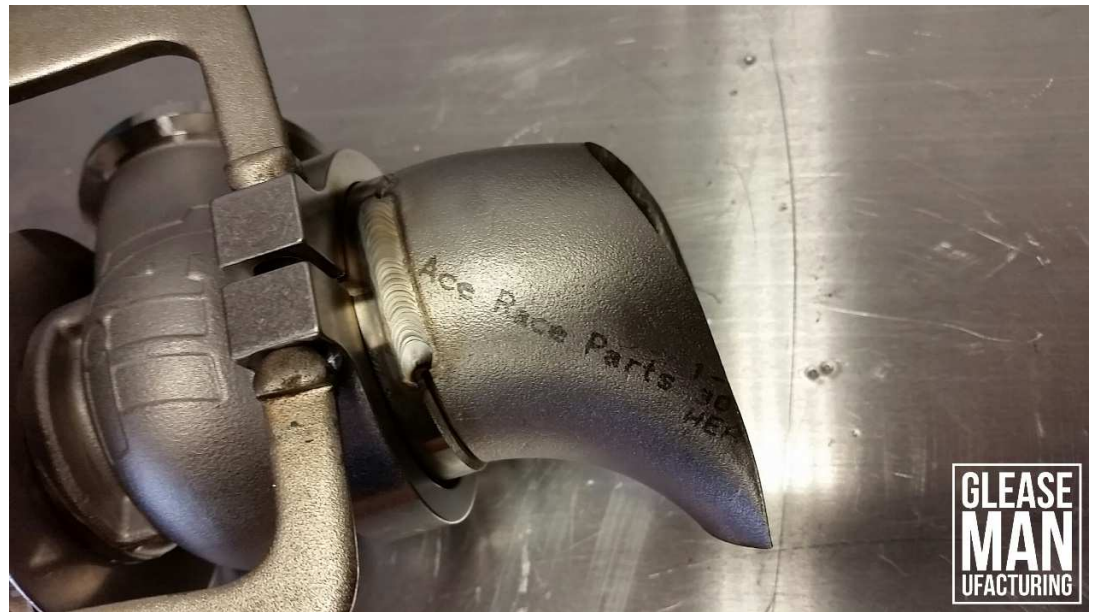

The entire manifold is Tig welded together and back purged throughout the entire process. Back purging means capping each end of the pipe being welded, and flowing Argon gas through it to keep oxygen away from the welds. This keeps the weld from “sugaring” on the inside of the pipe, which can break off in use and kill a turbine wheel. **This is the only acceptable method of manufacturing a turbo manifold.** The pipes are polished and prepped with a large chamfer on each end to allow full penetration. Perfect alignment of the pipes keeps turbulence from occurring in the primaries.



Fitment /Positioning

The manifold accommodates most RX7 based turbos. The pictures shown below show fitment using a Borg Warner EFR 9180 on a RHD FD. **We recommend upgrading from the worn factory engine mounts due to tight fitment to the frame, although have ran the manifold on good condition stock mounts with success.**





Wastegates / Dump Tubes

The manifold comes with three wastegate configurations. Two Tial MV-S 38mm gates, Turbosmart 40mm gates, or no wastegate provisions for internally gated turbos.

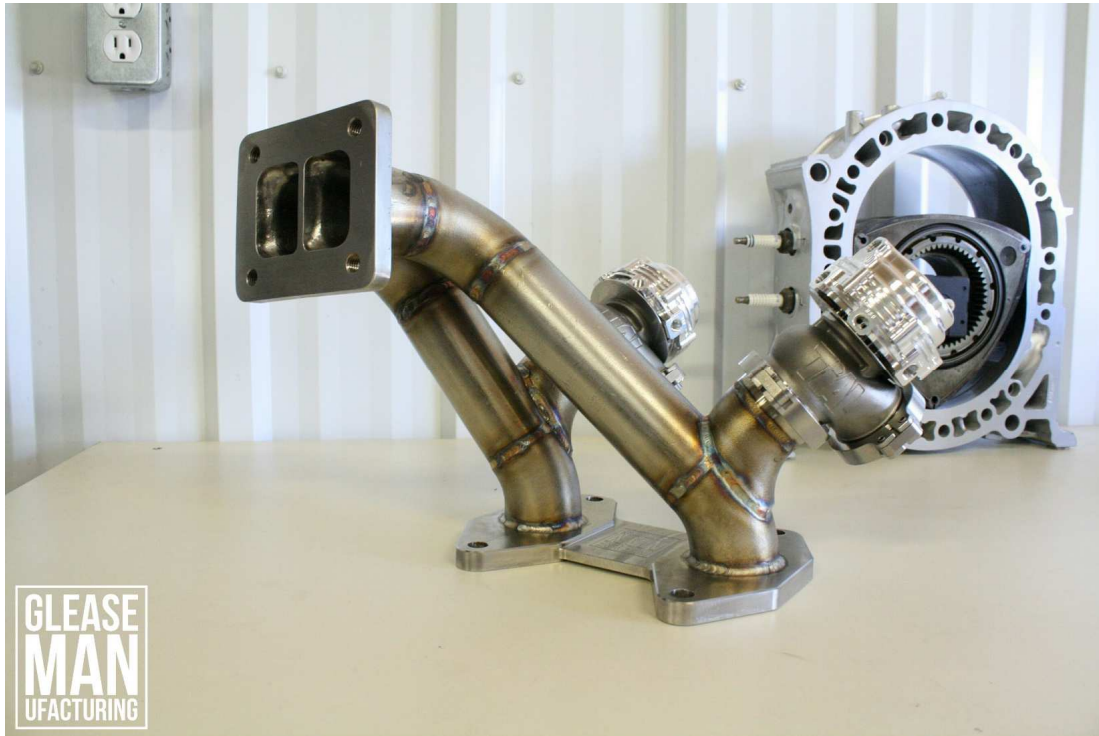

Our dump tubes are built to your wastegate selection and are a cheap and easy purchasable solution to exhaust the wastegates past the subframe.

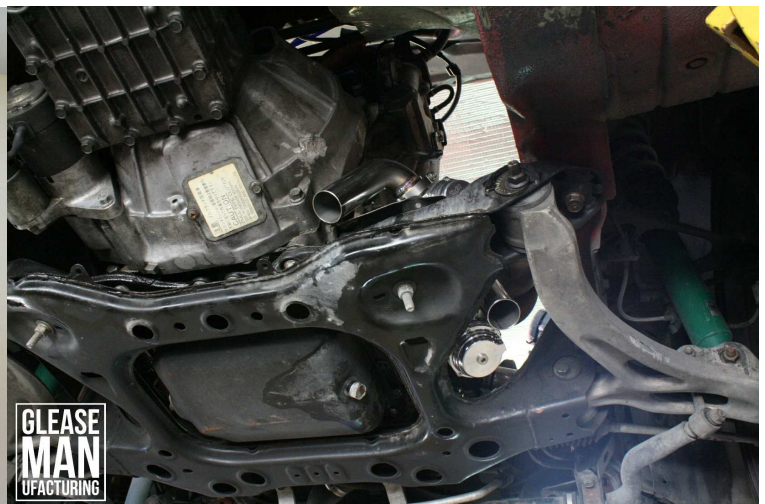

Downpipe

Our stainless 4" downpipe is a direct bolt on to the stock mid-pipe and fits most turbo applications. We will fabricate the inlet v-band to the specific turbo application, and the same for the outlet. We can add a v-band to the outlet, and make it any pipe size required. **We only use high quality flex pipes.** Available without them as well.



Hardware

We offer high quality studs and stainless fasteners for installation. We've found studs are key in keeping a proper seal between the turbo and manifold long term.



Warranty

Lifetime to first owner

High end features

321 Stainless Primaries

An option to build the manifold primaries from 321 stainless instead of 304 stainless is available and is very affordable. 321 stainless is **stabilized with Titanium**, which makes it the most heat and crack resistant stainless available. This is perfect for a rotary application that will see the race track. The welding rod used is also changed to allow proper welding of 321. **We are the only company that offers this option in the RX7 world.**

Billet Stainless Steel Merge Collector

Our newest feature to this manifold line up is the option to replace the welded collector with a CNC machined Stainless merge collector that was machined from a solid block of stainless. This makes them twice as strong as the collector than any other welded merge collector, ever. **The attractive part is that it allows for a perfectly tapered transition from the primaries to the T4 flange. We are the only company that offers billet collectors for RX7's.**

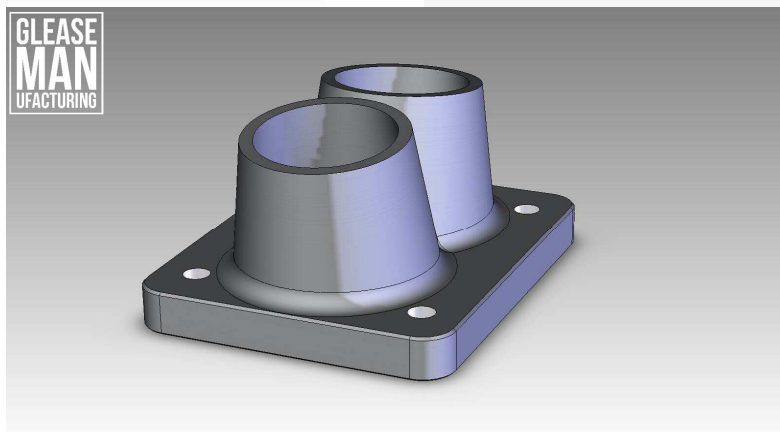
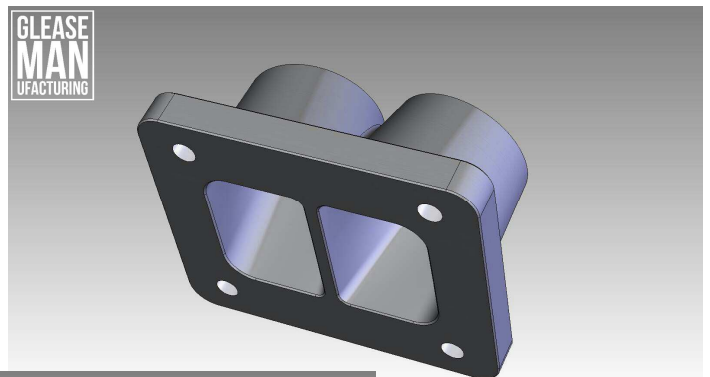
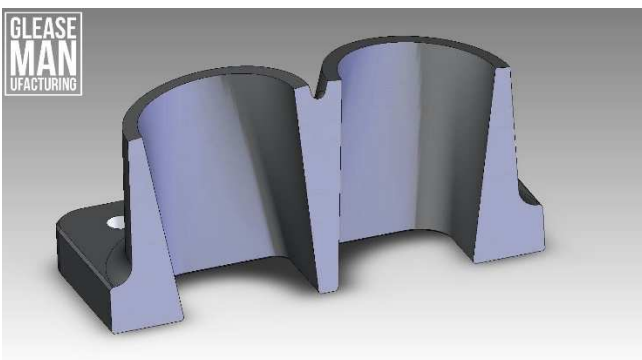

Summary

Fits all common RX7 turbos. GT35R, GT40R, GT42R, T04Z, 6766, S366, S400, EFR7670, EFR 8374, EFR 9180.

Features:

- Precision tig welded, and fully back purged
- Twin Scroll, Twin Wastegate (Tial MV-S 38mm, Turbosmart Comp40, or none)
 - Tear dropped high flow wastegate entry
- CNC machined and port matched 0.500" stainless flanges
- Thick wall 304 or 321 stainless 1.5" Sch40 primaries (321 is stabilized with Titanium for the ultimate crack resistance)
 - Both flanges sanded perfectly straight after welding
 - Hand ported T4 flange (Soon to be CNC)
 - Stainless fasteners and studs available
- Downpipe available with any size connection for your existing exhaust setup. (4", 3", 3.5") with v-band for inlet, and gasket for outlet.

Options:

- 4" 304 stainless Downpipe
- Wastegate dump tubes
- 321 stainless primaries
 - Pyrometer bungs
 - RHD Option

Retail Pricing: (USD Varies, price will fluctuate slightly)

Manifold - External wastegate - \$975.00 CANADIAN+tax (About \$780.00 USD)

Manifold - Internal wastegate - \$900.00 CANADIAN+tax (About \$675.00 USD)

321 stainless primaries - +\$200.00 CANADIAN+tax (About \$150.00 USD)

Wastegate dump tubes - \$150.00 CANADIAN +tax (About \$113.00 USD)

4" Downpipe - \$650.00 CANADIAN +tax (About \$488.00 USD)

Warranty:

Lifetime to first owner.



GLEASE
MAN
UFACTURING



GLEASE
MAN
UFACTURING



Gleaseman 2015