

MAT'L: 1 5/8"Ø x 0.134 WALL EWS				
BENDER FILE	PLASMA FILE	QTY	PART DESCRIPTION	LENGTH
		1	MAIN HOOP	107.99
		2	BACK BRACE	36.00
		2	SIDE BAR	52.00
		2	LATERAL SUPP'T	30.00
		1	SEAT CROSSMEMBER	44.25
		1	ROOF HOOP	78.60
		2	WINDSHIELD RUNNER	49.28
		1	DASH BAR	44.25

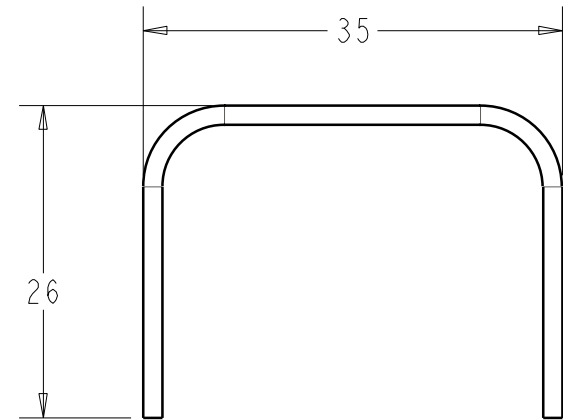

NOTE:

1. SPRING TEST AT 45° & 90° BEFORE PRODUCTION.
2. USE 6" R DIE RADIUS FOR ALL BENDS.
3. SEAMS ON MAT'L ARE TO BE ON INSIDE OF BENDS.

0	24NOV03	JEB	INITIAL RELEASE
REV	DATE	BY	DESCRIPTION
10-POINT ROLL CAGE		93-96 MAZDA RX7	
S & W RACE CARS SPRING CITY, PA			11-5552TD