

TW-2 INSTALLATION DIAGRAMS

TWO WINDOWS SHOWN

ALL VEHICLES WITH 2-WIRE MOTORS

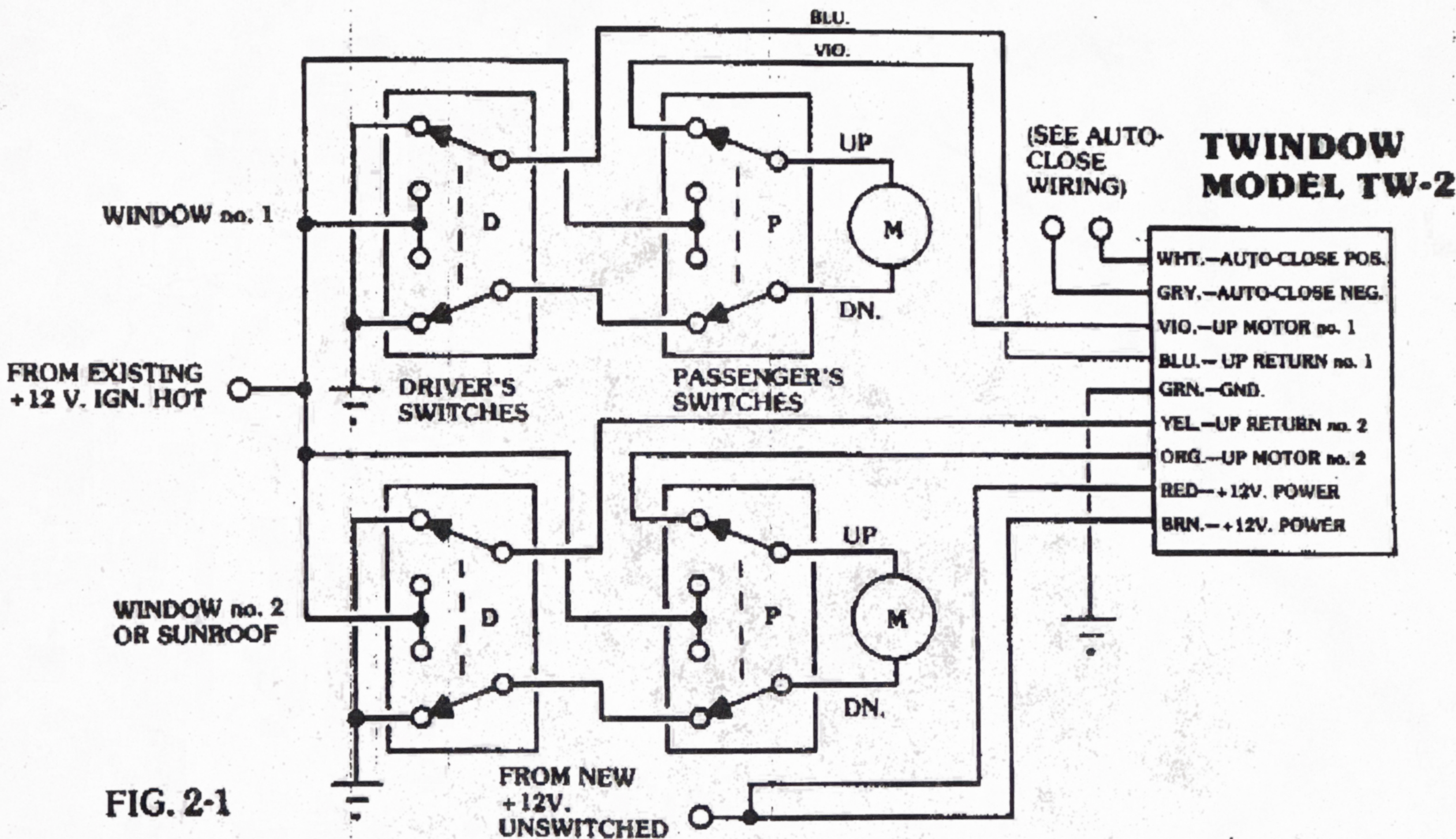

CAUTION: Be careful not to reverse connection of Violet and Blue wires, or Yellow and Orange wires. See Section 8B.2, Page 2, in Guide.

GM VEHICLES WITH 3-WIRE MOTORS

