

EXAMPLE CONNECTIONS

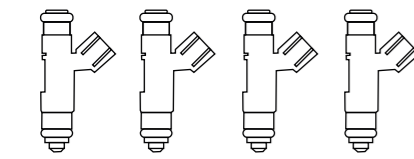

INJECTORS

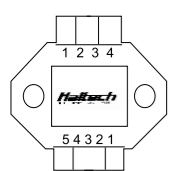

IGNITION MODULE

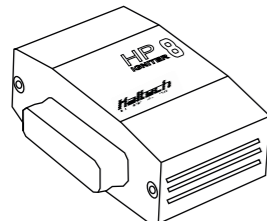

HALTECH HPI

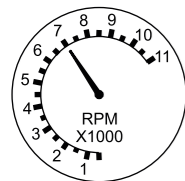

TACHOMETER

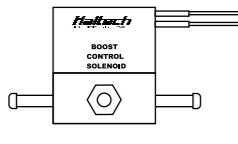

BOOST CONTROL SOLENOID

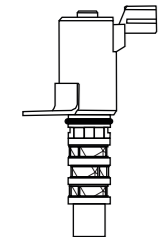

VTEC SOLENOIDS

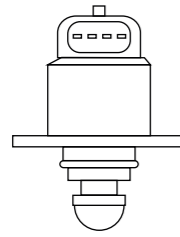

IDLE MOTOR

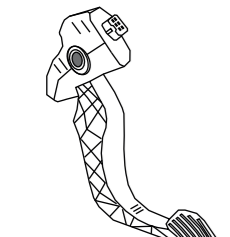

ACCELERATOR PEDAL POSITION SENSOR

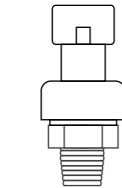

PRESSURE SENSORS

INJECTORS

4 X INJECTOR DRIVERS

- CURRENT CONTROLLED
- 0A - 8A PEAK CURRENT
- 0A - 2A HOLD CURRENT

ALL SPARE INJECTOR OUTPUTS CAN BE USED AS GENERIC DPO'S WITH 1A MAX OUTPUT

OUTPUT: GROUND

IGNITION

4 X IGNITION DRIVERS

- 1A MAX CURRENT
- OVERCURRENT PROTECTED

ALL SPARE IGNITION OUTPUTS CAN BE USED AS GENERIC DPO'S WITH 1A MAX OUTPUT

OUTPUT: GROUND

DPO

6 X DIGITAL PULSED OUTPUTS

- LOW SIDE DRIVE
- 1A MAX CURRENT
- OVERCURRENT PROTECTED

OUTPUT: GROUND

STEPPER 1 / DPO

CAN BE CONFIGURED AS

- 1 X STEPPER MOTOR DRIVER PAIRED P1 & P2 / P3 & P4
- 4 X HI/LOW SIDE DRIVERS

SPECIFICATIONS

- 1A MAX CURRENT DRIVE
- 1A MAX CURRENT SINK
- OVERCURRENT PROTECTED

OUTPUT: BATT V OR GROUND

AVI

10 X ANALOGUE VOLTAGE INPUTS

- SWITCHABLE 1K PULL-UP
- 20V MAX INPUT VOLTAGE
- 1.5KHz MAX INPUT FREQUENCY
- INPUT: 0V - 5V (20V MAXIMUM)

+5V SENSOR SUPPLY

- 100mA MAX OUTPUT CURRENT

+8V SENSOR SUPPLY

- 1A MAX OUTPUT CURRENT

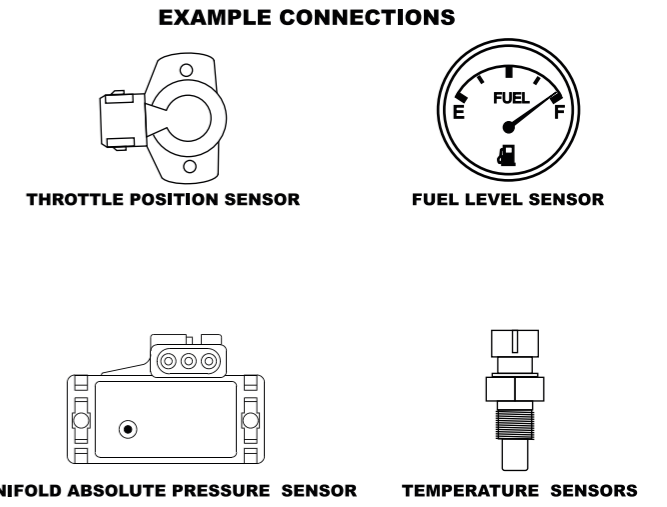
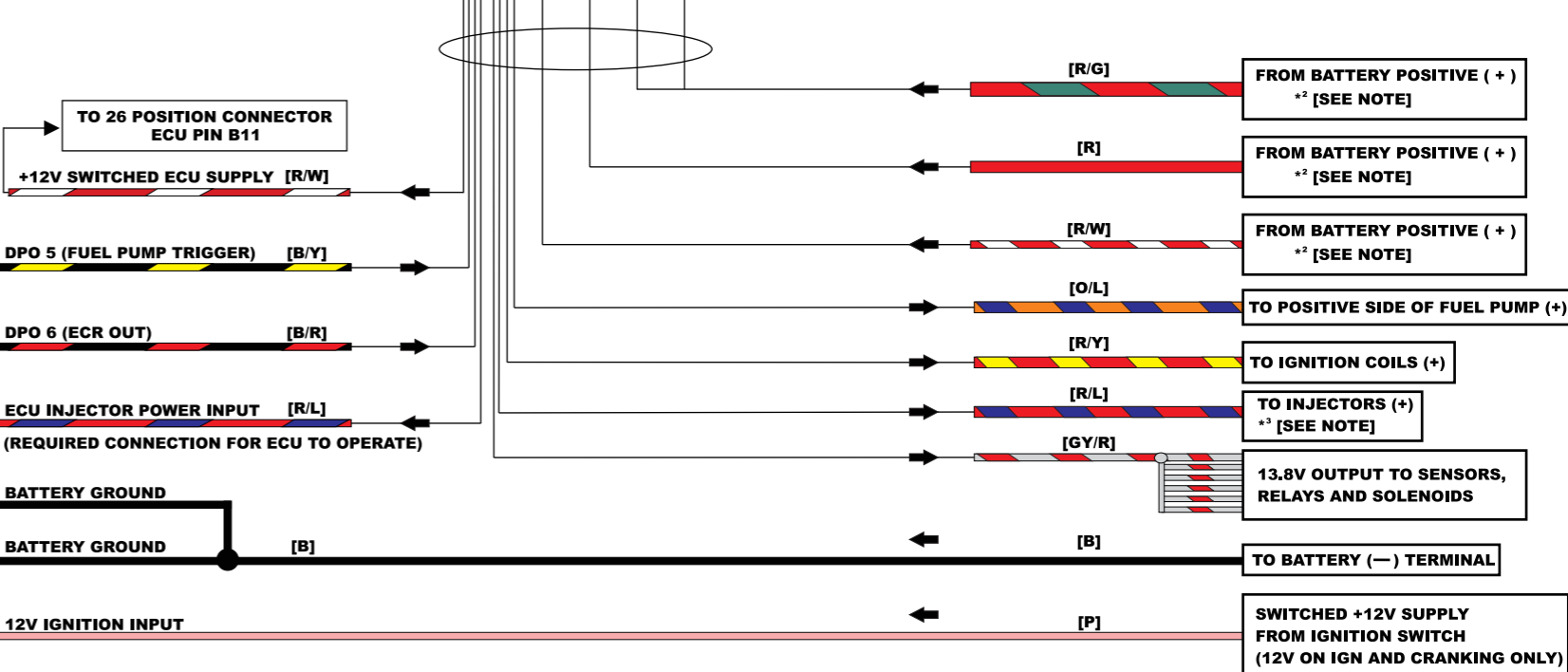
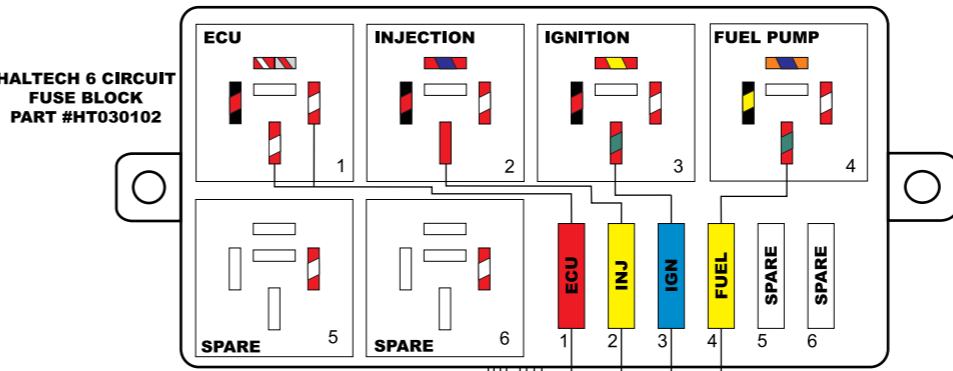
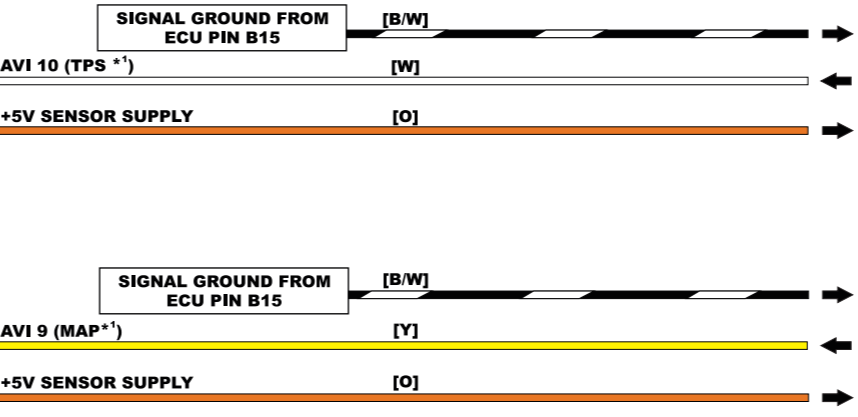
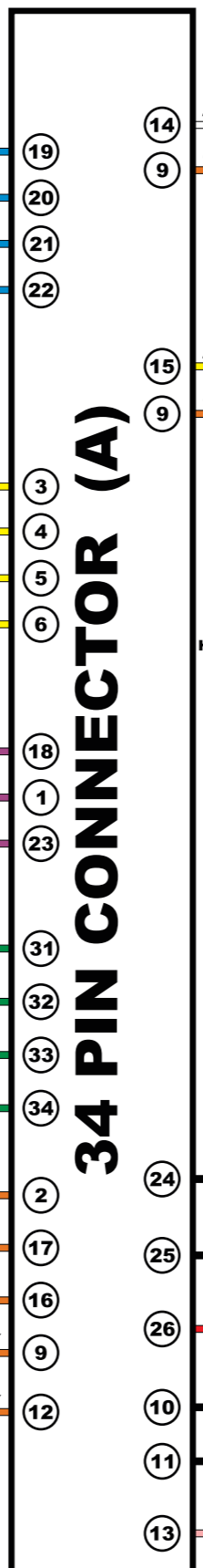
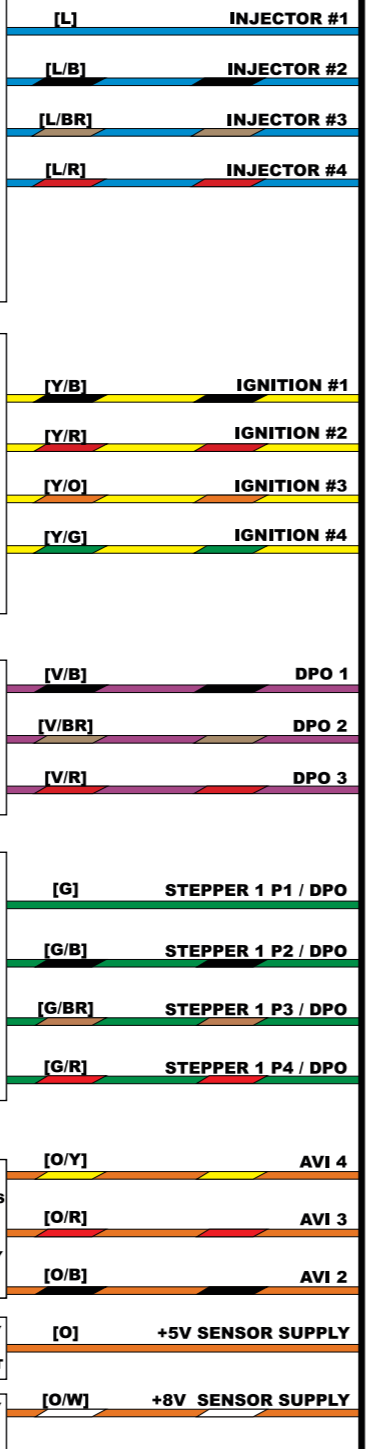

FUSE BLOCK NOTES:
15A CONTINUOUS, 20A PEAK
MAX CURRENT RATING PER CIRCUIT

FUSE ALLOCATIONS
FUSE 1: 10A - ECU
FUSE 2: 20A - INJECTION
FUSE 3: 15A - IGNITION
FUSE 4: 20A - FUEL PUMP
FUSE 5: SPARE
FUSE 6: SPARE

RELAY PIN LAYOUT & SCHEMATIC

SUITS 4 OR 5 PIN
STANDARD BOSCH RELAY

LOOKING INTO CONNECTOR ON ECU

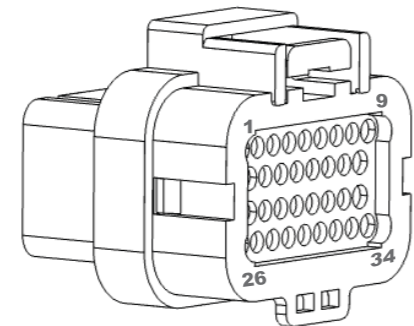
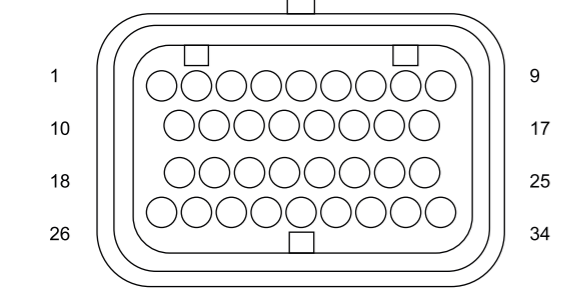

LEGEND - WIRE COLOUR
B = BLACK BR = BROWN G = GREEN GY = GREY L = BLUE
O = ORANGE P = PINK R = RED V = VIOLET Y = YELLOW W = WHITE
WHEN TWO COLOURS ARE USED IN A WIRE BY THE ALPHABETICAL CODE,
THE FIRST LETTER INDICATES THE BASIC WIRE COLOUR,
THE SECOND COLOUR INDICATES THE COLOUR OF THE STRIPE.

NOTES:
*1 RECOMMENDED FUNCTION ALLOCATION,
BUT NOT LIMITED TO
*2 CAN USE 75A CIRCUIT BREAKER
*3 HARNESS SUPPLIED SUPPORTS ELITE 1500.
UNUSED CONNECTIONS CAN BE REMOVED,
PLEASE REFER TO DIAGRAM ABOVE.

EXAMPLE CONNECTIONS

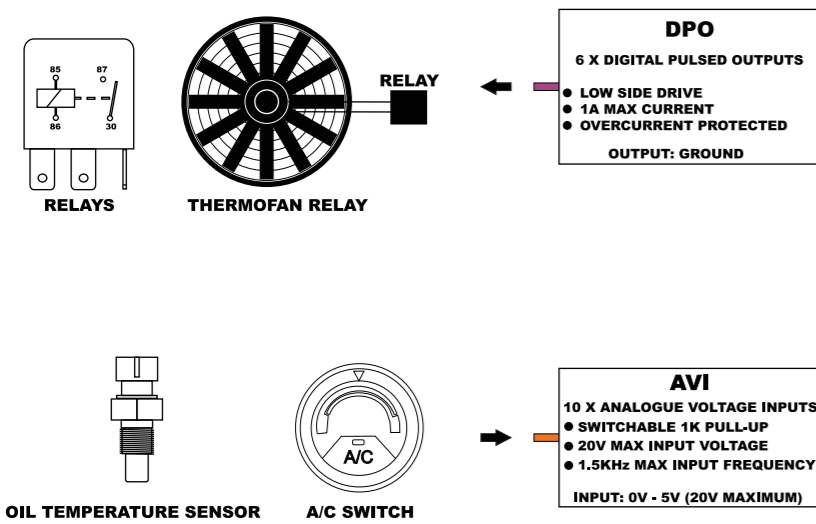

EXAMPLE CONNECTIONS

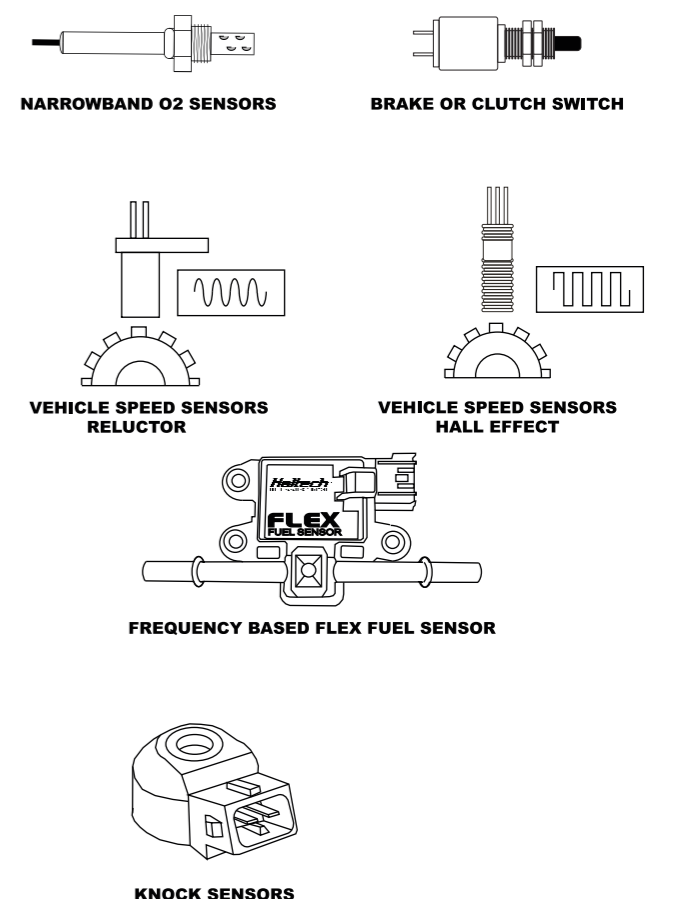
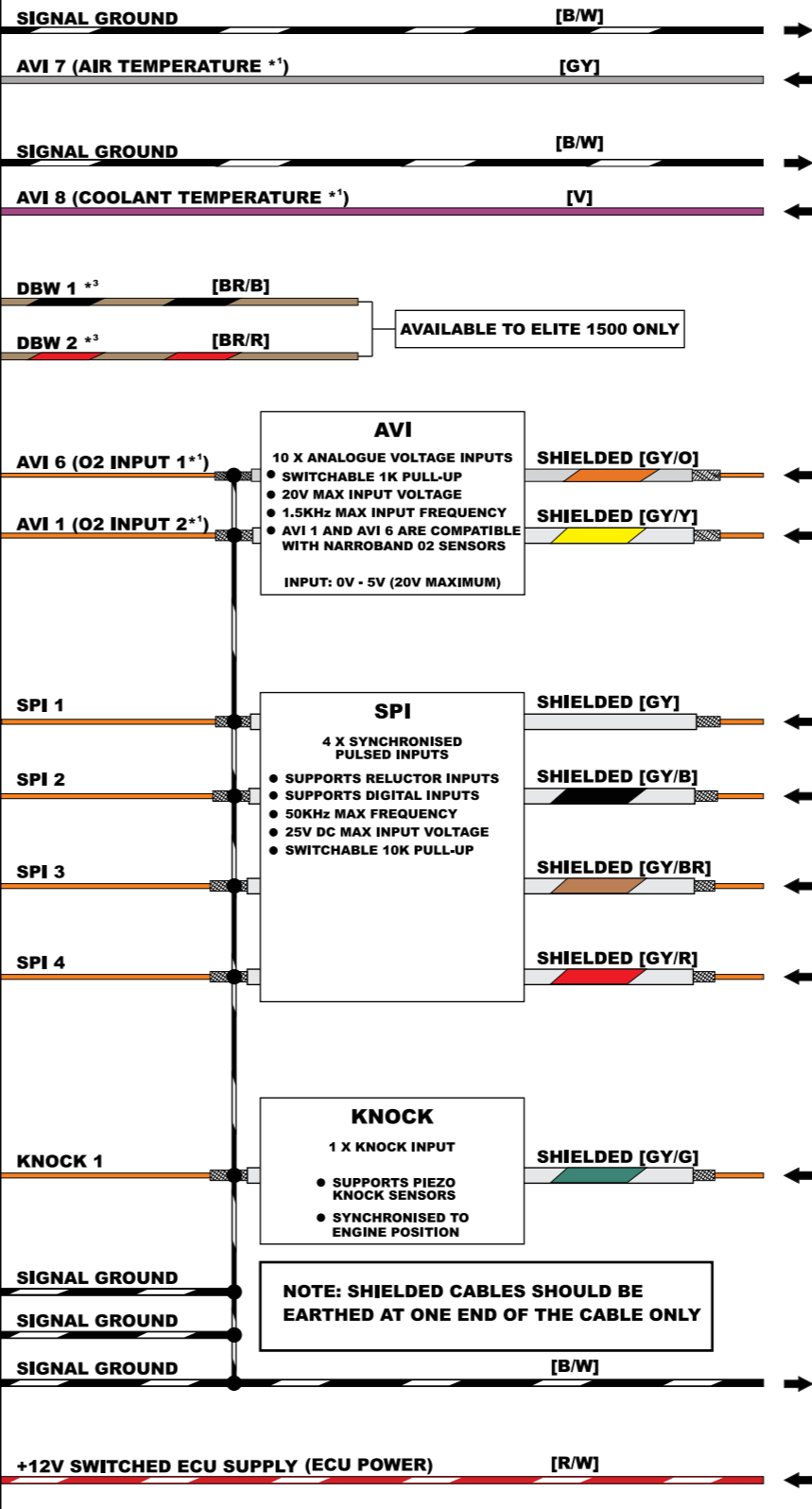
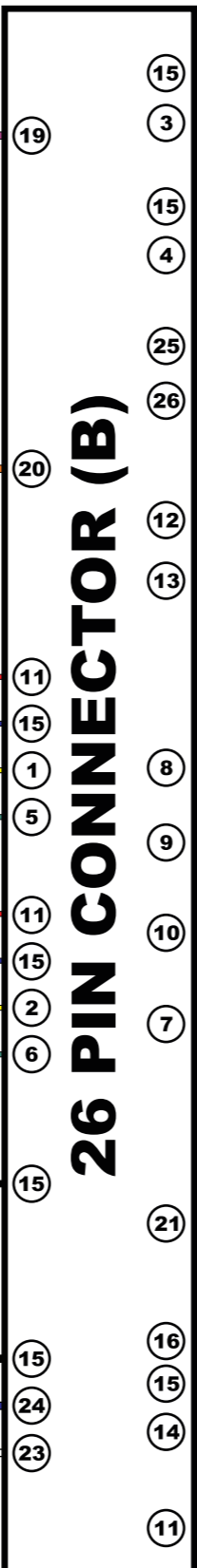
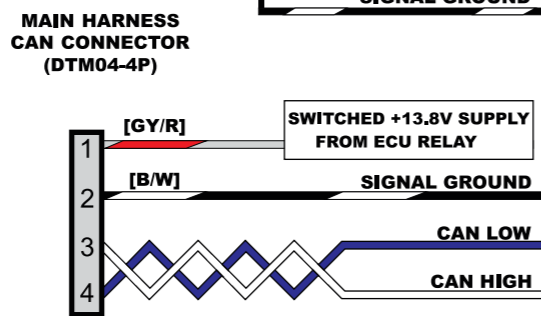
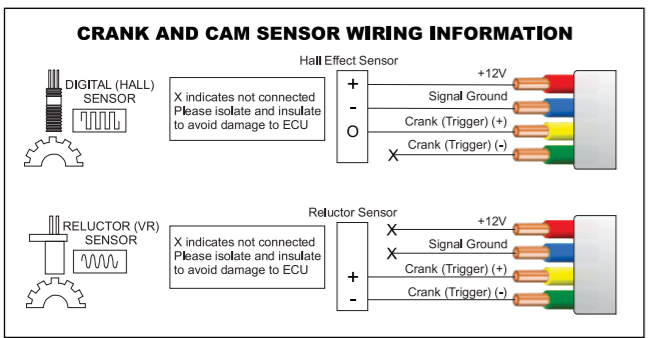
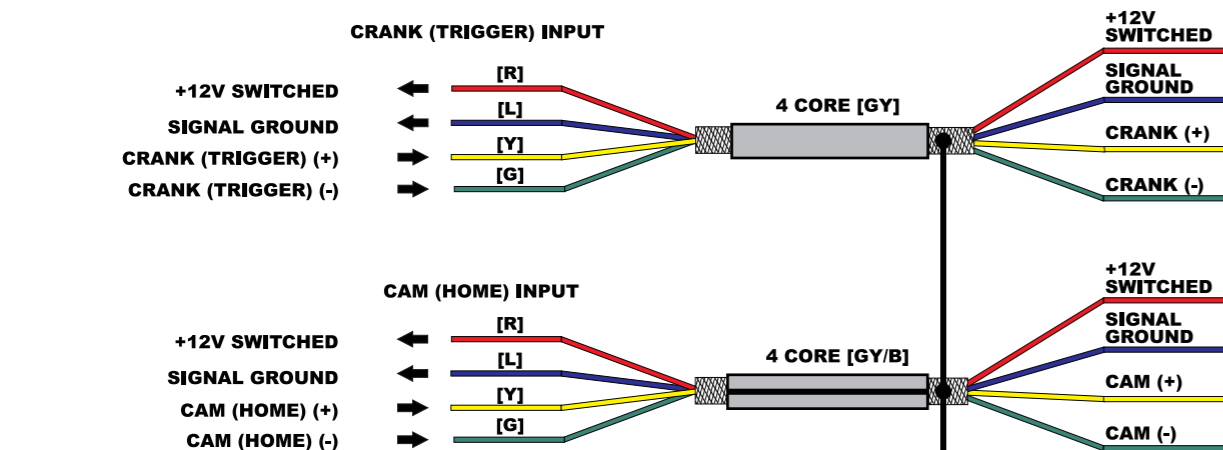
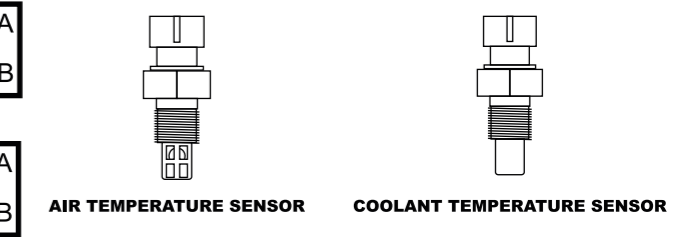

LOOKING INTO CONNECTOR ON ECU

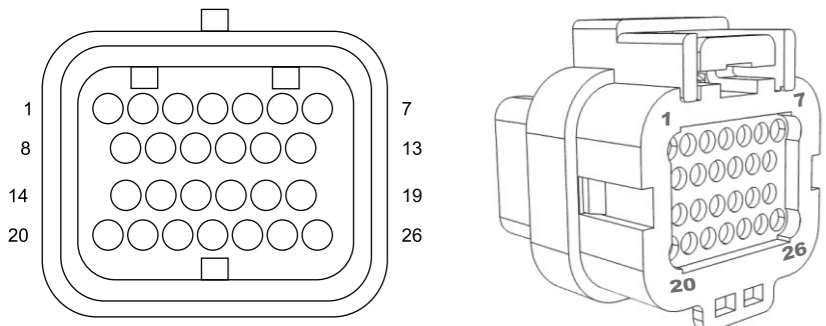

LEGEND - WIRE COLOUR
B = BLACK BR = BROWN G = GREEN GY = GREY L = BLUE
O = ORANGE P = PINK R = RED V = VIOLET Y = YELLOW W = WHITE
WHEN TWO COLOURS ARE USED IN A WIRE BY THE ALPHABETICAL CODE,
THE FIRST LETTER INDICATES THE BASIC WIRE COLOUR,
THE SECOND COLOUR INDICATES THE COLOUR OF THE STRIPE.

NOTES:
*1 RECOMMENDED FUNCTION ALLOCATION, BUT NOT LIMITED TO
*2 CAN USE 75A CIRCUIT BREAKER
*3 HARNESS SUPPLIED SUPPORTS ELITE 1500. UNUSED CONNECTIONS CAN BE REMOVED, PLEASE REFER TO DIAGRAM ABOVE.