

VEHICLE DETAILS

Chassis number ¹: FD3S-204457

Manufacture date: 1994

Make: MAZDA

Model: EFINI RX-7

Body: E-FD3S

Grade: TYPE R

Engine: 13B-REW

Drive: 2WD

Transmission: F5

Title information ²:



Deregistered to Export



Accident / Repair:



Problem found



Odometer rollback:



No problem



Manufacturer recall:



Problem found



Safety grade ³:



No data



Contamination risk:



No problem



This vehicle does not qualify for Buyback Guarantee

Average Market Price



Unfortunately, this vehicle does not qualify for our Buyback Guarantee program.







[About Buyback Guarantee](#)



¥850,000

This CAR VX Vehicle History Report is based only on Information supplied to CAR VX, LTD and available as of 2019-11-10 17:45:29. Other information about this vehicle, including problems, may not have been reported to CAR VX, LTD . Use this report as one important tool, along with a vehicle inspection and test drive, to make a better decision about your next used car.



ACCIDENT / REPAIR HISTORY

Problem type	Reported	Date reported	Data source	Details	Airbag
Collision	 Reported				
—	—	2016-03-05	HAA Kobe	Repaired	OK
Malfunction	 Reported				
—	—	2016-02-25	Hanaten Osaka	Heavy	OK
Theft	 Not reported				
Fire damage	 Not reported				
Water damage	 Not reported				
Hail damage	 Not reported				

ODOMETER READINGS HISTORY

Date reported	Data source	Odometer reading (Km)
2006-05-25	MLIT	77100
2016-02-25	Hanaten Osaka	79167
2016-03-05	HAA Kobe	79167

USE HISTORY

Use in the contaminated regions ⁴	Radioactive contamination test fail ⁵	Commercial use
 Not reported	 Not reported	 Not reported

DETAILED HISTORY

Event date	Location	Odometer reading (Km)	Data source	Details
1994			MAZDA	Manufactured
1994-08			MLIT	First registration
2006-05-25		77100	MLIT	Inspection

2016-02-24	Izumi		MLIT	Last registration
2016-02-25	Osaka	79167	Hanaten Osaka	Auctioned
2016-03-05	Hyogo	79167	HAA Kobe	Auctioned

MANUFACTURER RECALL HISTORY

Date reported	Data source	Affected part	Details
2000-11-21	MLIT	Car body	Aftermarket plastic hood, which is sold as goods (Mazda Speed ??Earobo N'netto) for locking device structure of the striker is inappropriate of, and continue to use as it is, the welding portion of the striker is damaged, the worst If, hood open while driving, there is a risk to damage the front glass.

VEHICLE ASSESSMENT ⁶

Overall Collision Safety Ratings

Driver's seat			Front passenger's seat		
Points	Evaluation	Goal average	Points	Evaluation	Goal average

* In order to accurately differentiate between the evaluations of different vehicles, a standard is set based on current technology. Up to 6 points out of 12 is given level 1 and the rest of the range is divided up into equal parts, which are respectively assigned to level 2 (more than 6 points but 7.5 or less), level 3 (more than 7.5 points but 9 or less), level 4 (more than 9 points but 10.5 or less) or level 5 (more than 10.5 points).

Braking performance tests ⁷



VEHICLE SPECIFICATION

1st gear ratio

2nd gear ratio

3rd gear ratio

4th gear ratio

5th gear ratio		6th gear ratio	
Additional notes		Airbag position, capacity	
Body rear overhang		Body type	COUPE
Chassis number embossing position		Classification code	106
Cylinders		Displacement	1308CC
Electric engine type		Electric engine maximum output	
Electric engine maximum torque		Electric engine power	
Engine maximum power	265PS(-)/6500RPM	Engine maximum torque	300KG*M(2942NM)/5000RPM
Engine model	13B	Frame type	
Front shaft weight	630	Front shock absorber type	DOUBLE WISHBONE
Front stabilizer type		Front tires size	225/50R16 92V
Front tread	1460	Fuel consumption	
Fuel tank equipment	76	Grade	TYPE R
Height	123	Length	428
Main brakes type		Make	MAZDA
Maximum speed		Minimum ground clearance	
Minimum turning radius	5100	Model	EFINI RX-7
Model code	E-FD3S	Mufflers number	
Rear shaft weight	630	Rear shock absorber type	DOUBLE WISHBONE
Rear stabilizer type		Rear tires size	225/50R16 92V
Rear tread	1460	Reverse ratio	
Riding capacity	4	Side brakes type	
Specification code	6937	Stopping distance	
Transmission type	F5	Weight	1260
Wheel alignment	2WD	Wheelbase	2425

AUCTION DATA

Date: 2016-02-25, Auction: Hanaten Osaka, Lot #: 9388

Date:	2016-02-25	Lot #:	9388
Auction name:	Hanaten Osaka	Region:	Osaka
Make:	MAZDA	Model:	RX-7
Reg. year:	1994	Mileage (km):	79167
Displacement (cc):	0	Transmission:	F5
Color:	BLACK	Model code:	FD3S
Result:	sold	Auction grade:	***
Problem type:	Malfunction	Problem scale:	Heavy
Contaminated:	No	Airbag:	OK

Date: 2016-03-05, Auction: HAA Kobe, Lot #: 70008

Date:	2016-03-05	Lot #:	70008
Auction name:	HAA Kobe	Region:	Hyogo
Make:	MAZDA	Model:	EFINI RX-7
Reg. year:	1994	Mileage (km):	79167
Displacement (cc):	0	Transmission:	F5
Color:	BLACK	Model code:	FD3S
Result:	sold	Auction grade:	R
Problem type:	Collision	Problem scale:	Repaired
Contaminated:	No	Airbag:	OK

PHOTOS AND AUCTION SHEETS

出品番号 9388	初度登録年月 6/8月	車名 RX-7	ドア形状 3 HB	グレード 20R	2WD	4WD	評価点 717°R
車歴	型式 E-FD3S	排気量 Re	cc	燃料 ソリ・軽油・()	現		

車検年 月	AT
走行 配号 十 万 千 百 十 一 79167キロ	AT 5速 MT車の記入

セールスポイント

無効

内装
A
B
C
D

外装色 元色 70 色替 →	冷房
カラーNO P2	保証書 取 脱

純正品のみ印	PS	PW	AW	SR	ABS
	革シート	エアバック	ナビ	TV	チューナー

輸入車 ディーラー・並行	ハンドル位置 右・左	モデル年式	年	有	有
-----------------	---------------	-------	---	---	---

車検証欄	書類期限	月	日
------	------	---	---

預託済リサイクル料金 9,310.円 乗車定員 人

◎注意事項

0円売り切り

全長 cm

全幅 cm

全高 cm

ナビ取脱	ナビロム	SDカード	B-CAS	リモコン	プレート	キー類	スマートキー
ハンドル	シート	オーディオ	ホイール(C/P)	エアロ	ドアミラー		
A・スレ	A・スレ	無し・穴	A・ワレ	A・ワレ	A・ワレ		

検査員記入 FW A・X要ス 室内シート コゲ・穴・汚れ・キズ・破れ

エンジンから現状車

フロントハブ コアサボット)XX

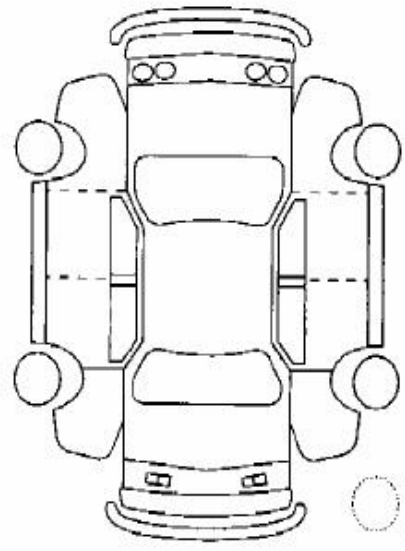

小キズ有・小凹有

キーコーナ

左 右

希望出品ブロックに○印

車体NO FD3S-204457

色替車は記入しない
不具合箇所・後日送付品等を記入(ナビロム・プレート等)

社外品含む





出品番号 70008	型式 E-FD3S	排気量 RE CC	車歴 自家用・レンタ・()	評価点 R
	初年度登録 6/8月	車名 RX-7 3 HB	ドア形状 717°R	グレード 2WD 4WD
車検	年	月	燃料 G・D・ハイブリッド・()	定員 ()人
				積載量 kg

走行 マイル 79,167 Km	AT MP MP (5)速	セールスポイント
外装色 70 カラーNo (PZ)	ダッシュ (5)速	
色替率は()内に「色替」と記入	内装色 70	
リサイクル預託済金額 9,310 円	新車保証書 (保証欄完備のもの)	

登録番号 (ナンバープレート)	保証書	取扱説明書	純正 装備品 新備品のみ 印を記入	PS	PW	AW	サンルーフ	ABS
車台番号 FD3J-204457				本革	エアバッグ	ナビ	TV	Dチューナー (純正・社外含む)

輸入車	年式 (西暦)	輸入 区分	ディーラー・並行	ハンドル	左・右	シリアルNo
-----	------------	----------	----------	------	-----	--------

名変期限	月	日迄
出品店記入 (注意事項)	外装・7 (R-777) マフラー TE37 17インチ AW、D席外シート ロールオーバー、外ハンドル	
検査員記入	内装	シート
	ウス汚れ・汚れ・コゲ キズ スレ コゲ 穴 キレ シミ ナシ 穴	
	コアサポート ×× BP 足み	FE 2 パネ BP 足み
		F サイト × パネ BP 足み
入	カーナビ	オイル もれ
		タビ 変形

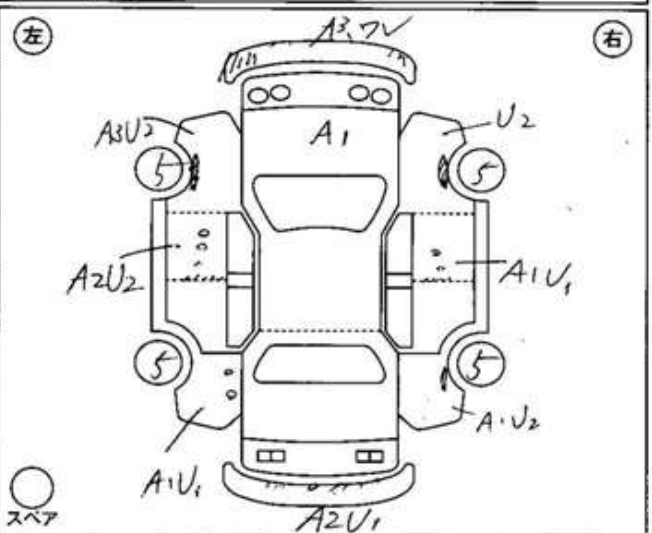

ホイール	ドアミラー	小キズ	小ヘコミ
キズ ワレ	キズ ヒビ ワレ	(有)	(有)

ドレスコーナー	検査員氏名 野田 征也	長さ cm	幅 cm	高さ cm	ロック cm
---------	-----------------------	----------	---------	----------	-----------



¹ Chassis number – a unique identification number of the vehicle in Japan (same as VIN in the USA or Europe)

² Title information:

Registered – qualified for driving in Japan

Deregistered Temporarily – not qualified for driving in Japan, usually a temporary title during the ownership change

Deregistered Completely – not qualified for driving in Japan, the vehicle is determined to be scrapped

Deregistered to Export – not qualified for driving in Japan, the vehicle is determined to be exported

³ Determining the overall collision safety performance evaluation – For the driver's seat, the results of the full-wrap frontal collision test, offset frontal collision test, and side collision test are added together and evaluated to 6 different levels. For the Frontal passenger's seat, the results of the full-wrap frontal collision test and the side collision test (results for the driver's or the front passenger's seat are used) are added together and evaluated to 6 different levels.

Regular vehicle inspection – All vehicles in Japan must undergo regular vehicle inspections (shaken). New cars need to be tested after three years, and then vehicles must be tested every two years thereafter. A vehicle inspection (shaken) is compulsory for all vehicles with an engine size over 250cc. It ensures that all vehicles on the road are properly maintained and safe to drive. The test also checks that vehicles have not been illegally modified; if they are found to have been modified, they are not allowed on the road.

⁴ Use in the contaminated regions – The Fukushima Daiichi nuclear disaster was a catastrophic failure at the Fukushima I Nuclear Power Plant on 11 March 2011, resulting in a meltdown of three of the plant's six nuclear reactors. As a result, some areas in the following prefectures were contaminated: Fukushima, Miyagi, Ibaraki, Tochigi.

⁵ Radioactive contamination test – radioactive contamination inspection that was started in July 2011 as a preventive measure for exporting contaminated vehicles from Japan. The inspection is being conducted since in all sea ports of Japan under the supervision of The Japan Harbor Transportation Association (JHTA).

MLIT – Ministry of Land, Infrastructure, Transport and Tourism.

⁶ Japan New Car Assessment Program – the Ministry of Land, Infrastructure, Transport and Tourism (MLIT) and the National Agency for Automotive Safety & Victims' Aid (NASVA) have taken measures for safety, one of which is to assess commercially available vehicles through a variety of safety performance tests and release the resulting information compiled into the "New Car Assessment Program". The objective of Japan New Car Assessment Program is to increase the use of safe automobiles by providing an environment in which users can easily select such vehicles. This also promotes the development of safer vehicles by automobile manufacturers. Neck injury protection for rear-end collision performance test, rear seat passenger's protection for frontal collision performance test, rear passenger's seat belt usability evaluation test and seat belt reminder for passengers evaluation test are started in FY2009.

⁷ Braking Performance Tests – Braking performance is determined by the shortness of the distance in which a vehicle can stop and the stability of the vehicle at the time of braking. This test is performed under wet and dry road conditions for a vehicle which has both a driver and a front passenger. The distance it takes for the vehicle to stop and the stability of the vehicle at the time of braking is evaluated for when the vehicle is stopped abruptly while traveling at a speed of 100km/h. The stopping distance and vehicle speed have been measured by using GPS since FY2009.

CAR VX, LTD DEPENDS ON ITS SOURCES FOR THE ACCURACY AND RELIABILITY OF ITS INFORMATION. THEREFORE, NO RESPONSIBILITY IS ASSUMED BY CAR VX, LTD OR ITS AGENTS FOR ERRORS OR OMISSIONS IN THIS REPORT. CAR VX, LTD FURTHER EXPRESSLY DISCLAIMS ALL WARRANTIES, EXPRESS OR IMPLIED, INCLUDING ANY IMPLIED WARRANTIES OF MERCHANTABILITY OR FITNESS FOR A PARTICULAR PURPOSE.

© 2014-2019 Car VX Limited. All rights reserved.