

Notes:

1. This drawing documents the electrical schematic and wiring installation of a Link G4+ Fury Engine Management Unit in my modified 1993 Mazda RX7.
2. This drawing references the 1993 Mazda RX7 Factory Shop Manual (FSM), Section Z Electrical Schematics and is intended to supplement the Mazda FSM.

3. All electrical schematic symbology conventions and wire color codes referenced in the Mazda FSM shall be utilized herein unless otherwise noted.

4. Notes on this sheet apply to all sheets in this drawing. Additional notes specific to the content of each sheet may be added to that sheet as applicable.

5. The OEM Mazda ECU, part # N3A1-18-881A, and the OEM Mazda Emissions (EM) ECU Wiring Harness, part # N3A1-18-05ZG, have been removed and replaced by the Link G4+ Fury ECU and a custom fabricated wiring harness, respectively. This wiring harness shall be designed and constructed to applicable motorsports standards, and relevant Military Standards applicable to ground vehicles.

6. Wire Specifications:

6a. Wire for the CAS and Knock Sensors shall be IAW M27500/20SBT23 (20AWG x2 twisted/shielded pair); Wire for all other conductors used in the Link G4+ ECU Wiring Harness shall be IAW M22759/23-20 (20AWG) or M22759/32-18 (18AWG), depending on maximum current draw of the circuit after de-rating.

6b. Wire utilized for all new or modified/upgraded power distribution circuits shall be IAW industry standard SAE-J-1128 for TXL insulated automotive wire.

7. All wires illustrated in this drawing are 18 or 20 AWG, unless specified otherwise in brackets after the wire color designation, e.g., W(12AWG).

8. Firewall bulkhead connector set <J1/P1_MIL> shall be IAW MS3470L22-55S for the firewall side Recepticle (female/sockets), and MS3476L22-55P for the Engine side Plug (male/pins). Refer to sheet 8 for further detail.

9. Main Wiring Harness shall be environmentally sealed with the appropriate diameters of Raychem DR-25 heat shrink tubing, and appropriate size DR-25 heat shrink boots on both sides of <J1/P1_MIL>.

10. Major system and wiring components called out in this schematic are located as follows in the car:

10a. Link G4+ ECU is mounted in same right side kick panel location as OEM ECU, in a custom fabricated aluminum mounting bracket.

10b. ECU Fuse Block is mounted on the left side spring tower, adjacent to the battery in the engine bay. Terminations at ECU Fuse Block are ring terminals, sized IAW wire gauge and terminal posts.

10c. Relay Panel Assembly is mounted adjacent to the Link G4+ ECU. Relays are socketed, and terminations are standard relay female spades, sized IAW wire gauge used.

10d. IGN-1A Ignition Coils (x4) are mounted in space vacated by the removed OEM Cruise Control Actuator Unit, in the rear, left corner or the engine bay.

10e. IGN Relay is an environmentally sealed and socketed unit, mounted on the left spring tower, adjacent to the ignition coils.

11. The OEM fuel pump relay and resistors are no longer used, but physically remain in place unconnected. As indicated in the schematic, the fuel pump (+) circuit side obtains power via new fuel pump relay controlled by the Link G4+ ECU. New 10/12AWG wiring and upgraded connectors are used for fuel pump power and ground. OEM connector <B1-06> no longer carries current to the fuel pump, but is retained for the fuel gauge and low fuel indicator warning circuits - Refer to Mazda FSM Section Z for schematics of these circuits.

Notes (Continued):

12. Ground Locations and Details:

12a. Battery (-) terminal is grounded to Engine Block at Starter Motor mounting bolt lug, and to main chassis ground post on the spring tower via separate, parallel wired 4AWG battery cables and copper lugs, respectively. These ground locations are indicated on the schematic by ground symbols annotated as "MAIN GND".

12b. Fuel Pump grounds to the existing OEM rear cabin ground location #12, <JC12>; OEM fuel pump wiring is replaced with new 12AWG ground wire and suitable lug. This ground location is indicated on the schematic by ground symbols annotated as "FP GND".

12c. Grounds for the Link G4+ Fury ECU and Relay Panel Assy. connect to chassis ground at the same M6-1.0 threaded hole location that was utilized by the OEM ECU, via new ground wiring (multiple parallel 18AWG wires) and suitable lugs as indicated in schematic. These ground locations are indicated on the schematic by ground symbols annotated as "ECU GND".

12d. Ref. Sheet #4, "SPARK GND #1 ROTOR" and "SPARK GND #2 ROTOR" denote M8x1.25 threaded holes on top of each rotor housing where IGN-1A Pin C of rotor #1 L1/T1 coil pair and rotor #2 L2/T2 coil pair grounds to their respective rotor housing. Wiring is M22759/32-18 from each coil pair's Pin C to a common 12AWG TXL ground wire and M8 lug.

12e. Ground for the Cooling Fans (Ref. Sheet #6) is an M6-1.0 threaded hole located on the lower front frame structure, adjacent to the right spring tower. Grounds are wired with new 12AWG wiring and suitable lugs as annotated in schematic by "FAN_GND".

13. Link G4+ ECU integration with the OEM Mazda wiring is through the OEM <X05> and <X14> connectors without modification to wiring on the OEM harness side of these connectors. For integration with OEM Front (F) Harness connector <B1-01>(F), the indicated wires on <B1-01>(F) are depinned and connected to <DTM12_X1000> for connections to the Link G4+ ECU. The unused <B1-01> connector and its wires are left in place insulated and secured.

Drawing Revisions History:

Version 1.0 - None, initial drawing release on 16 January 2021

Version 2.0 - The following revisions were made to the Version 2.0 drawing, dated 21 October 2021:

(a) Fuel Pump wiring revised to accomodate installation of a Walbro 450 fuel pump upgrade. Fuel pump current no longer passes through OEM <B1-06> connector; it now passes through a DTP connector, on 2x 12AWG M22759/32-12 wires (+ and GND return) to an in-tank Weather Pack connector on the fuel pump. An ATL wire pass-thru gland fitting at the tank bulkhead seals the 2x 12AWG wires passing through for liquid or vapor fuel leakage from the tank. All in-tank wiring and connectors are rated for use submersed in fuel. Ref. sheet #2 for details.

(b) The Engine Cooling Fan wiring was revised to improve reliability. The unsealed OEM <B2-05> and <B2-06> connectors were replaced by sealed Deutsch DT-Power series connectors, <DTP4_EFAN1> and <DTP4_EFAN2>, respectively. Some wire colors in the cooling fan circuit were changed due to materials availability. Ref. sheet #6 for details.

Version 3.0 - The following revisions were made to the Version 3.0 drawing, dated 1 May 2023:

(a) Wire colors on the DBW Throttle Body pigtail harness were changed. This was done because the DBW connector pigtail was replaced with a different vendor part, due to failure of the original part. Ref. sheets #4 and #9 for details.

Version 4.0 - This is a major revision to the drawing package, dated 8 December 2023. The following revisions were incorporated in Version 4.0:

(a) In order to incorporate additional functionality and future upgrades, the following Link G4+ I/O functional pin assignments were revised and rewired accordingly: (1) E-FAN#1 Relay is reassigned to INJ8 in lieu of AUX1; (2) Fuel Pump Relay is reassigned to IGN5 in lieu of AUX4; (3) START/CRANK input is directed to DI3 in lieu of DI4; User Input Switch #1 is directed to DI4 in lieu of DI3.

(b) A fuel vapor purge solenoid valve was fitted. Purge solenoid is driven by a PWM output on AUX4, using a 3D MAP vs RPM control strategy, similar to Mazda OEM ECU. Switched +12VDC power for purge solenoid is obtained from OEM (F) harness, B/W wire via <JB-06>. Ref. sheets 4 and 5 for wiring details.

(c) The Link G4+ now uses the FD instrument cluster's processed speedometer digital output signal for vehicle speed input in lieu of a shared parallel connection to the analog VSS sensor. This signal input is directed to DI1, ref. sheet #5 for wiring details. This revision was done to electrically isolate the Link G4+ from the OEM VSS sensor instrument cluster/VSS sensor circuit, to improve OEM speedometer accuracy.

(d) The <JST_CAN1> connector pigtail assembly was added to access CAN1 bus for gauges and instrumentation in lieu of using CAN2. This revision frees up DI9 and DI10 for future use as dedicated digital inputs.

(e) Remaining Link G4+ spare I/O signals are brought out to a connector for future use. Ref. sheet #5 for wiring details.

Title Link G4+ ECU Wiring Installation Schematic, 1993 Mazda RX7		
Author Peter W. Morel Subtitle: Drawing Notes and Revision Tracking Sheet		
File C:\Users\Peter W. ... FD Schematic-Rev4.0.dsn	Document FD3S-001	
Revision 4.0	Date 8 December 2023	Sheets 1 of 10

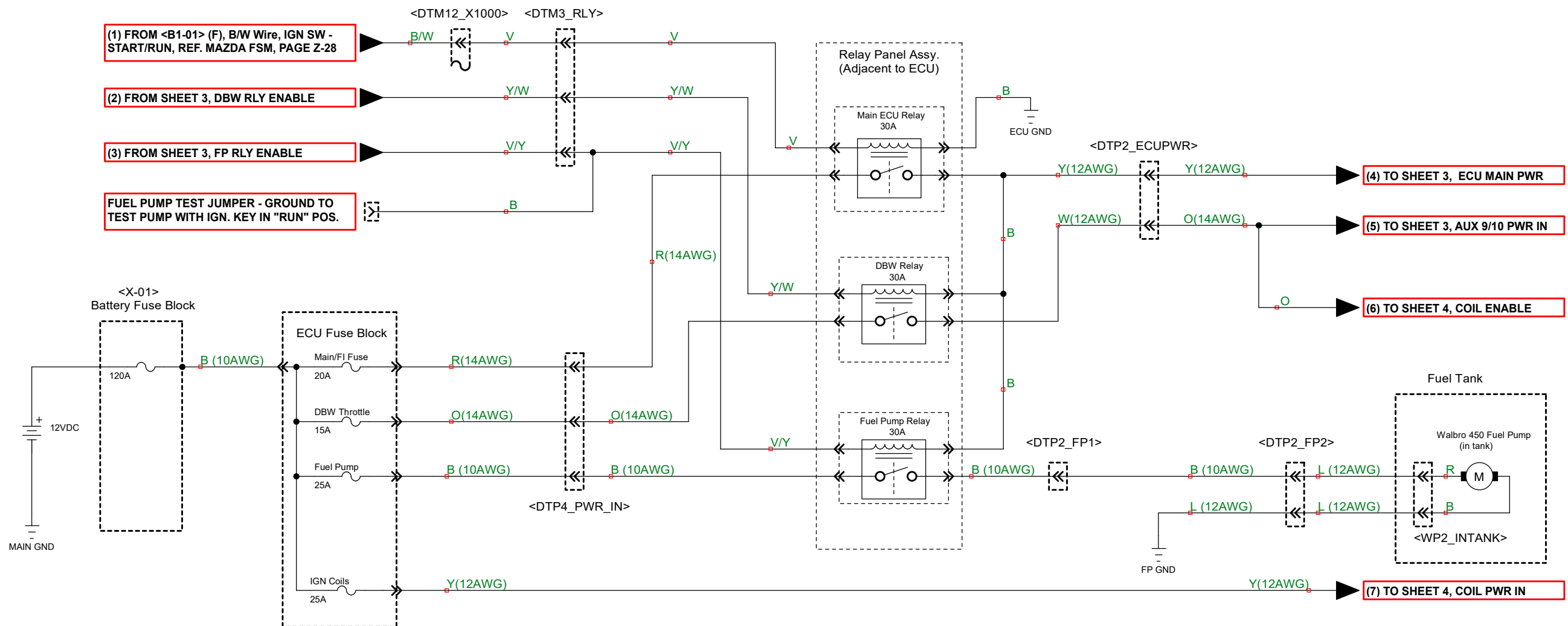

Notes:

1. Power input for the ECU Fuse Block is tapped at the 120A fused main battery power available at <X-01>, Battery Fuse Block. This connection is terminated with a ring terminal lug, on M6-1.0 bolt on <X-01>.
2. No other OEM circuits on the <X-01> fuse block have been modified or tapped for power; for clarity, only the one power tap connection to the new ECU Fuse Block is shown.
3. The FUEL PUMP TEST JUMPER is located adjacent to the Link G4+ ECU; it is hidden behind the glove compartment but is easily accessed without removing any trim pieces. Connecting this jumper to ground with the ignition key on will run the fuel pump, to test the fuel system for leaks during service operations.
4. The FP GND is located at the rear cabin ground location #12, <JC12> ground connector. Connection is made via lug terminal and M6-1.0 bolt at <JC12> chassis ground.
5. The two 12AWG wires passing through the fuel tank bulkhead on the fuel pump hanger pass through an ATL Fuel Cells CFD-504 Electrical Bulkhead Fitting, which seals the wire pass-thru from liquid or vapor fuel escape.
6. All wiring and connectors exposed to fuel are rated for permanent submerged fuel usage. This includes the <WP2_INTANK> connector, and the 12AWG M22759/16-12 Tefzel insulated wire.

Title Link G4+ ECU Wiring Installation Schematic, 1993 Mazda RX7		
Author Peter W. Morel Subtitle: Power Distribution & Fuel Pump Circuit Schematic		
File C:\Users\Peter W. ... FD Schematic-Rev4.0.dsn	Document FD3S-001	
Revision 4.0	Date 8 December 2023	Sheets 2 of 10

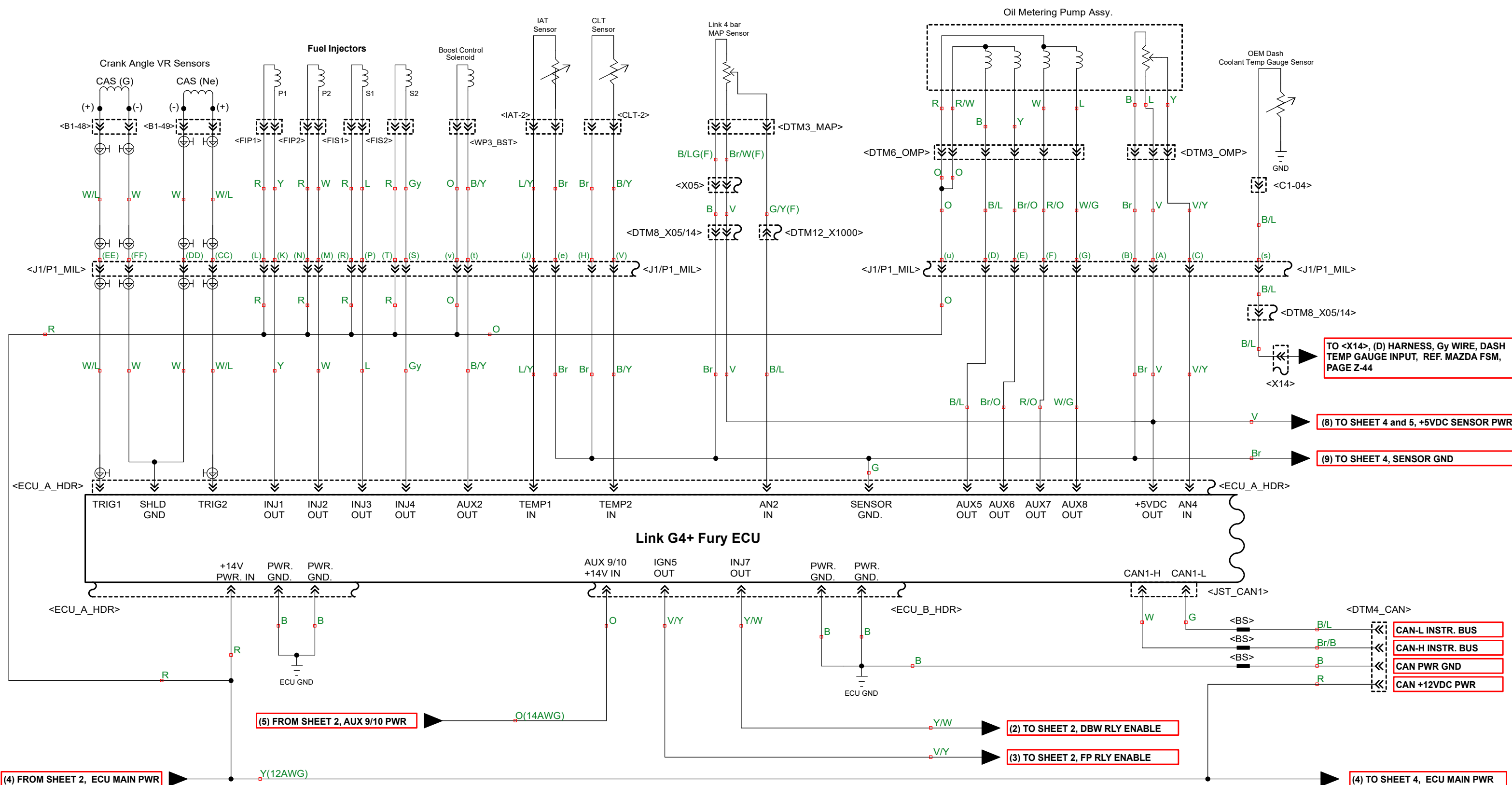

Notes:

- Pin numbers for <J1/P1_MIL> connector are indicated by bracketed characters adjacent to its terminals.
- Pin arrangement and nomenclature for <J1/P1_MIL> is IAW MS3470L22-55S and MS3476L22-55P item drawings. Note that upper case letters I, O and Q, and lower case letters I, and o are not used.
- Terminal (HH) of <J1/P1_MIL>, is not shown in the schematic. This pin is utilized as a common pass through termination for the shield conductor of shielded cables used for the CAS and Knock sensors.
- Revision 4.0: The black rectangle symbols labeled <BS> denote closed barrel butt-splice terminations, insulated with Raychem DR25 heat shrink tubing. These connect the <JST_CAN1> connector pigtail assembly to the existing CAN Instrument Bus wiring as detailed on this sheet..

Title Link G4+ ECU Wiring Installation Schematic, 1993 Mazda RX7		
Author Peter W. Morel Subtitle: Link G4+ ECU, Sensors & Output Devices, Sheet 1 of 3		
File C:\Users\Peter W. ... FD Schematic-Rev4.0.dsn	Document FD3S-001	
Revision 4.0	Date 8 December 2023	Sheets 3 of 10

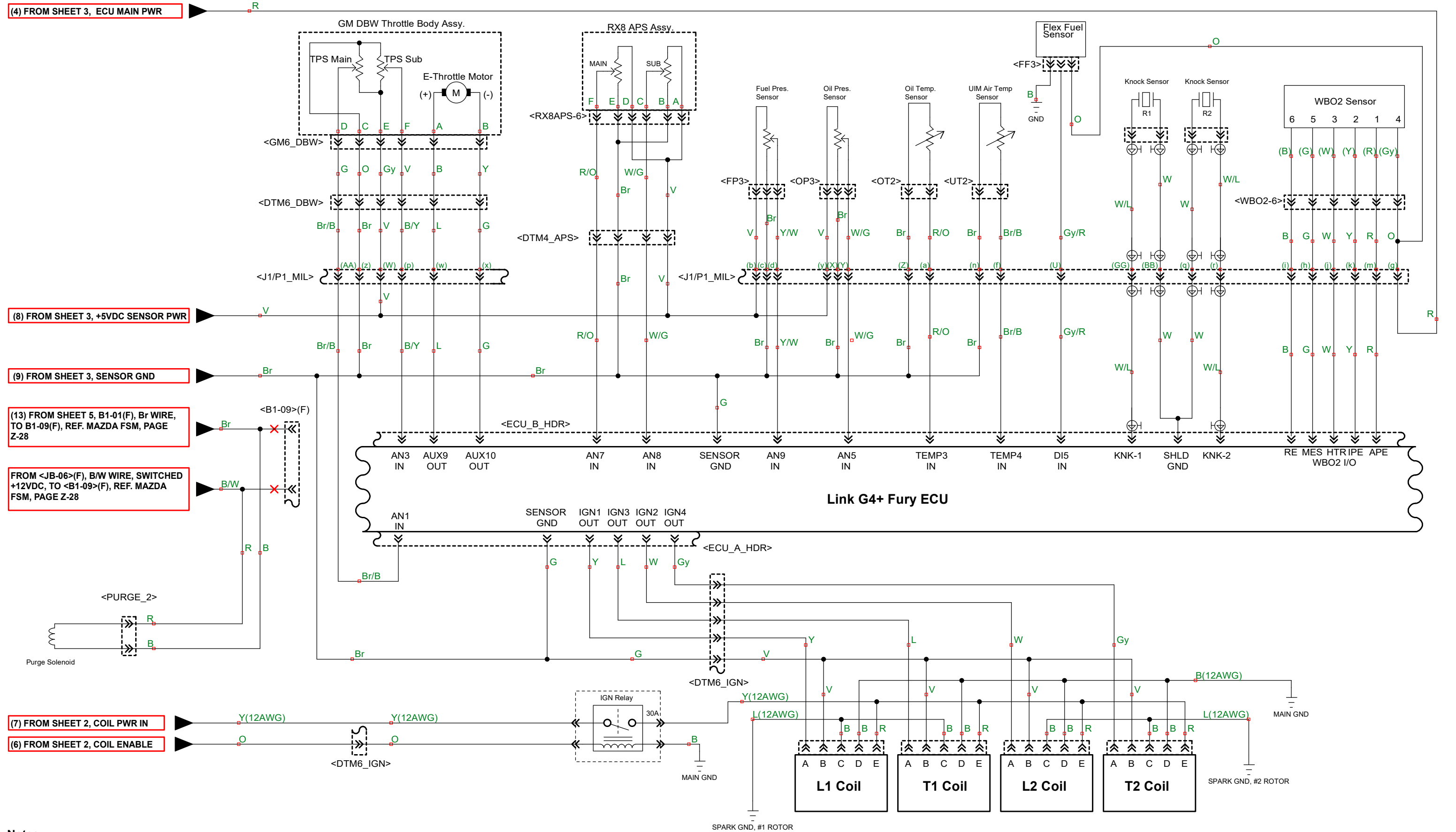

Notes:

1. Ground wire and lug for the Flex Fuel Sensor connects to the engine block via an M8-1.25 threaded hole, front rotor housing.
2. Revision 4.0: Added the Purge Solenoid, which utilizes OEM wiring in the (F) harness as indicated. OEM connector <B1-09>(F) is for reference only; this connector and the OEM Ignitor was removed by previous owner as it is no longer needed with the IGN-1A coils. Purge solenoid obtains switched +12VDC power from the B/W wire coming from <JB-06>(F). The R and B wires for the purge solenoid connect to the OEM wiring using uninsulated closed barrel butt crimps, insulated with Raychem DR-25 heat shrink tubing.

Title Link G4+ ECU Wiring Installation Schematic, 1993 Mazda RX7		
Author Peter W. Morel Subtitle: Link G4+ ECU, Sensors & Output Devices, Sheet 2 of 3		
File C:\Users\Peter W. ... FD Schematic-Rev4.0.dsn	Document FC3S-001	
Revision 4.0	Date 8 December 2023	Sheets 4 of 10

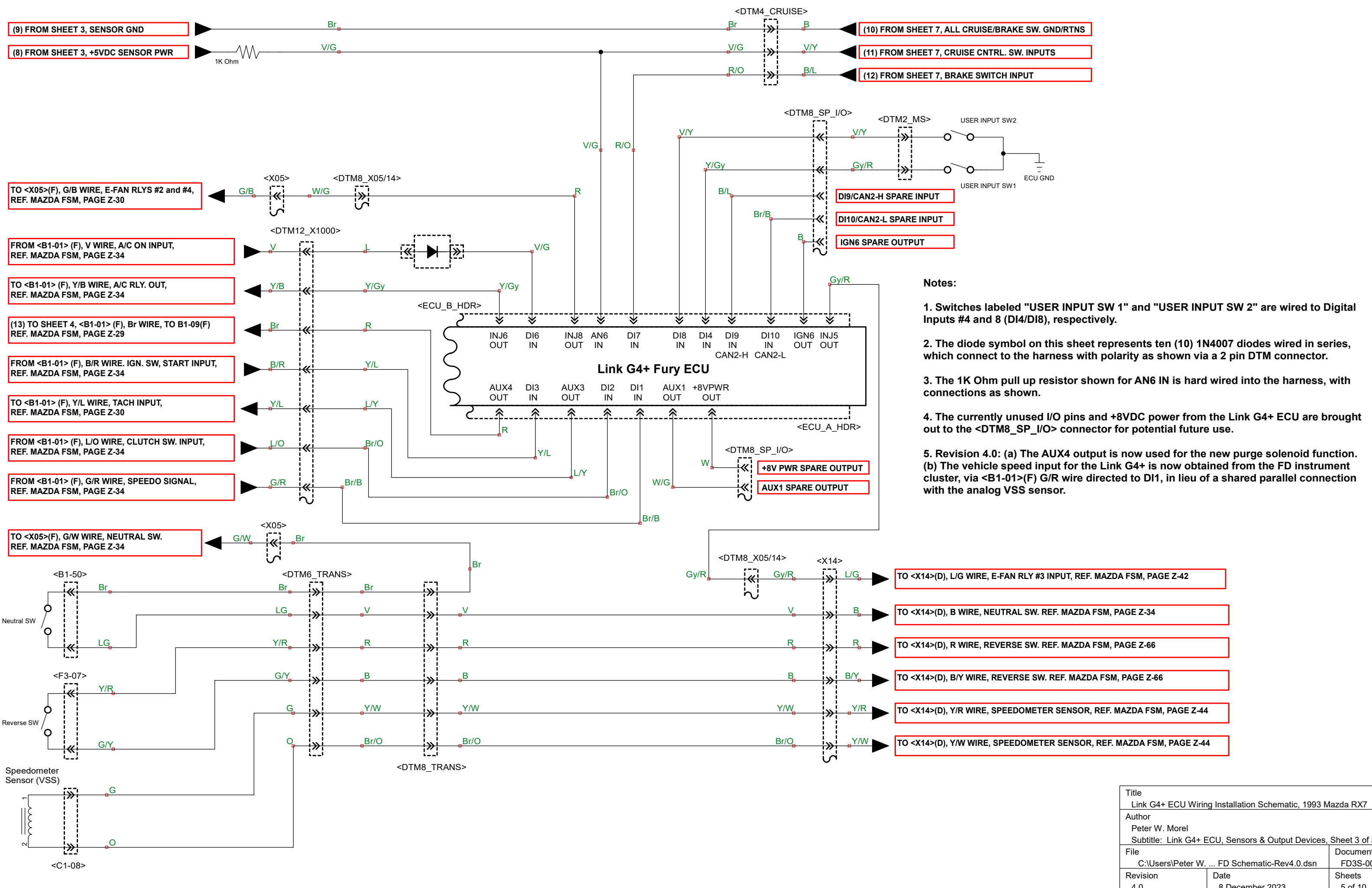

Notes:

- Switches labeled "USER INPUT SW 1" and "USER INPUT SW 2" are wired to Digital Inputs #4 and 8 (DI4/DI8), respectively.
- The diode symbol on this sheet represents ten (10) 1N4007 diodes wired in series, which connect to the harness with polarity as shown via a 2 pin DTM connector.
- The 1K Ohm pull up resistor shown for AN6 IN is hard wired into the harness, with connections as shown.
- The currently unused I/O pins and +8VDC power from the Link G4+ ECU are brought out to the <DTM8_SP_I/O> connector for potential future use.
- Revision 4.0: (a) The AUX4 output is now used for the new purge solenoid function. (b) The vehicle speed input for the Link G4+ is now obtained from the FD instrument cluster, via <B1-01>(F) G/R wire directed to DI1, in lieu of a shared parallel connection with the analog VSS sensor.

Title Link G4+ ECU Wiring Installation Schematic, 1993 Mazda RX7		
Author Peter W. Morel		
Subtitle: Link G4+ ECU, Sensors & Output Devices, Sheet 3 of 3		
File C:\Users\Peter W. ... FD Schematic-Rev4.0.dsn	Document FD3S-001	
Revision 4.0	Date 8 December 2023	Sheets 5 of 10

FROM <X-02>, L WIRE, (F) HARNESS, +12VDC CONSTANT PWR VIA 60A COOLING FAN FUSE, REF. MAZDA FSM, PAGE Z-42.

FROM <JB-05>, B/Y WIRE, (F) HARNESS, SWITCHED +12VDC PWR VIA 15A "METER" FUSE, REF. MAZDA FSM, PAGE Z-42.

FROM <B1-01> (F), V WIRE, THERMOSWITCH, A/C ON INPUT, VIA <DTM12_X1000> REF. MAZDA FSM, PAGES Z-34; Z-42; Z-68

FROM <X05>(F), G/B WIRES (1 of 2), E-FAN RLYS #2 and #4, REF. MAZDA FSM, PAGE Z-30; Z-42. PULL TO GND VIA LINK G4+ ECU.

FROM <X05>(F), G/B WIRES (2 of 2), E-FAN RLYS #2 and #4, REF. MAZDA FSM, PAGE Z-30; Z-42. PULL TO GND VIA LINK G4+ ECU.

FROM <X14>(D), L/G WIRE, E-FAN RLY #3 INPUT, REF. MAZDA FSM, PAGE Z-42. PULL TO GND VIA LINK G4+ ECU

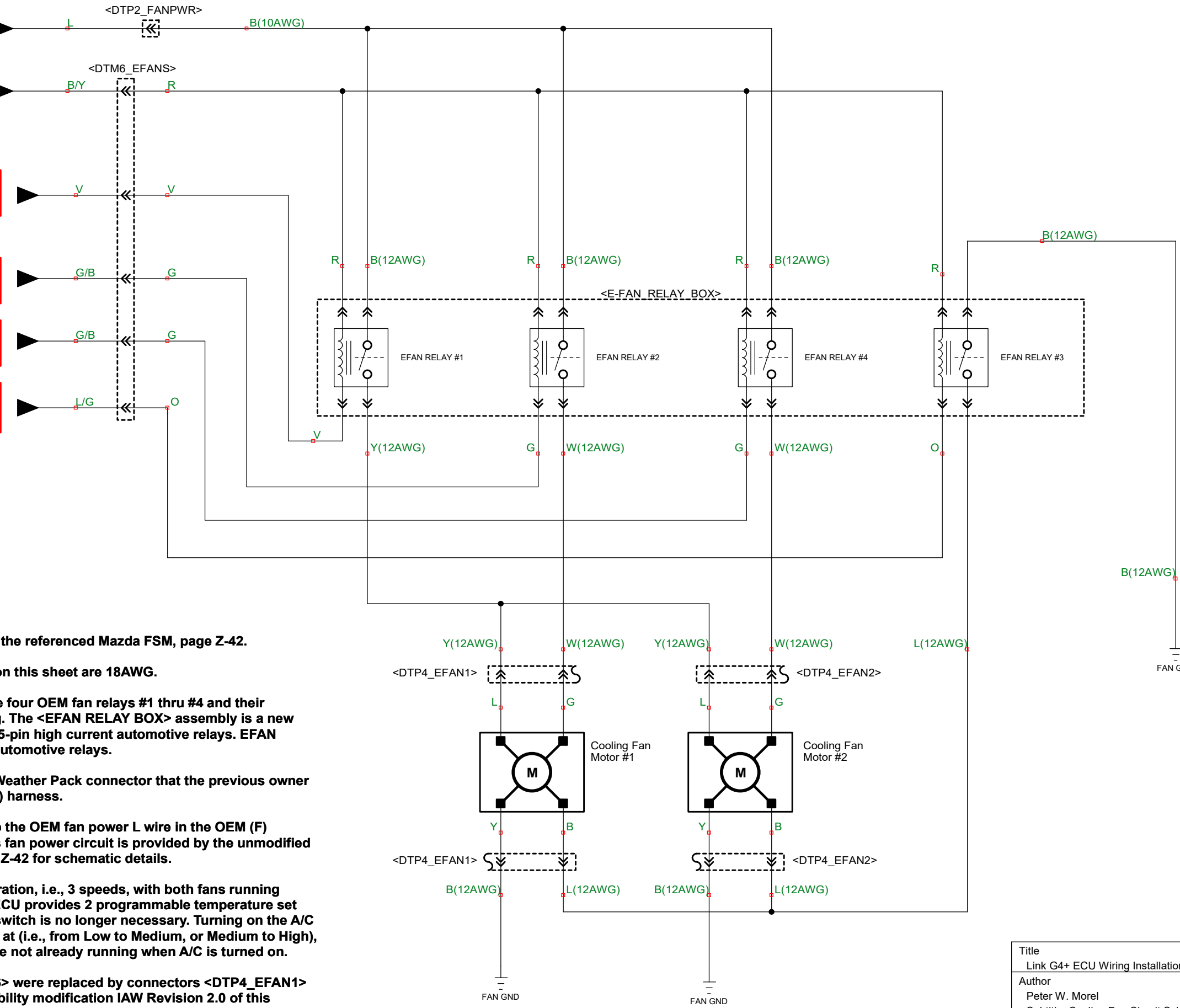

Notes:

1. This drawing sheet serves as a revision page to the referenced Mazda FSM, page Z-42.
2. Unless noted otherwise noted, all wires shown on this sheet are 18AWG.
3. As purchased from the car's previous owner, the four OEM fan relays #1 thru #4 and their associated relay sockets/connectors were missing. The <EFAN RELAY BOX> assembly is a new weather resistant enclosure that houses up to six 5-pin high current automotive relays. EFAN Relays # 1 through #4 are Bosch 40A SPDT 5-pin automotive relays.
4. The <DTM6_EFAN> connector replaces a 6 pin Weather Pack connector that the previous owner used to tap the indicated wires in the OEM front (F) harness.
5. The <DTP2_FANPWR> is a new connector to tap the OEM fan power L wire in the OEM (F) harness as shown. Over current protection for this fan power circuit is provided by the unmodified OEM 60A fuse in <X02>. Refer to Mazda FSM page Z-42 for schematic details.
6. The fans operate identically to the OEM configuration, i.e., 3 speeds, with both fans running simultaneously at the same speed. The Link G4+ ECU provides 2 programmable temperature set points to activate the fans, thus the OEM thermal switch is no longer necessary. Turning on the A/C increments the current speed the fans are running at (i.e., from Low to Medium, or Medium to High), or it will start the fans at Low speed if the fans were not already running when A/C is turned on.
7. OEM fan motor connectors <B2-05> and <B2-06> were replaced by connectors <DTP4_EFAN1> and <DTP4_EFAN2>, respectively. This was a reliability modification IAW Revision 2.0 of this drawing.

Title Link G4+ ECU Wiring Installation Schematic, 1993 Mazda RX7		
Author Peter W. Morel		
Subtitle: Cooling Fan Circuit Schematic		
File C:\Users\Peter W. ... FD Schematic-Rev4.0.dsn	Document FD3S-001	
Revision 4.0	Date 8 December 2023	Sheets 6 of 10

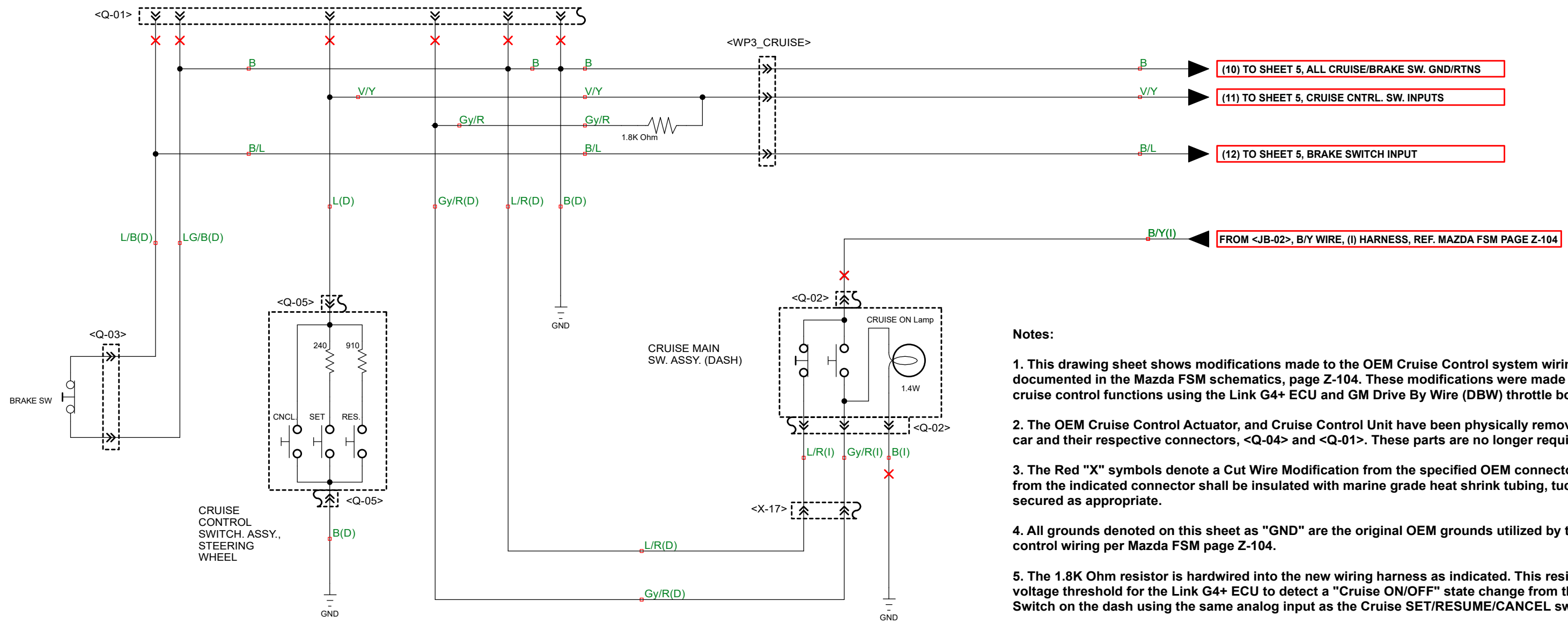

Notes:

1. This drawing sheet shows modifications made to the OEM Cruise Control system wiring as documented in the Mazda FSM schematics, page Z-104. These modifications were made to support cruise control functions using the Link G4+ ECU and GM Drive By Wire (DBW) throttle body.
2. The OEM Cruise Control Actuator, and Cruise Control Unit have been physically removed from the car and their respective connectors, <Q-04> and <Q-01>. These parts are no longer required.
3. The Red "X" symbols denote a Cut Wire Modification from the specified OEM connector. Cut ends from the indicated connector shall be insulated with marine grade heat shrink tubing, tucked and secured as appropriate.
4. All grounds denoted on this sheet as "GND" are the original OEM grounds utilized by the cruise control wiring per Mazda FSM page Z-104.
5. The 1.8K Ohm resistor is hardwired into the new wiring harness as indicated. This resistor sets the voltage threshold for the Link G4+ ECU to detect a "Cruise ON/OFF" state change from the Main Cruise Switch on the dash using the same analog input as the Cruise SET/RESUME/CANCEL switch.
6. Not shown on this sheet is the OEM Clutch Switch input to the Link G4+ ECU; refer to sheet 5 of this drawing package for that detail. In addition to the Brake Sw. input, the Link G4+ software utilizes the Clutch Sw. input to cancel cruise if either the brake or clutch pedal is depressed.
7. Cruise Control operational functionality as implemented with the Link G4+ ECU is identical to OEM functionality, with the following exceptions:
 - 7a. Indicator lamp on the CRUISE MAIN switch no longer illuminates to indicate when cruise is enabled.
 - 7b. Pressing EITHER the "Cruise On" or "Cruise Off" switches on the Cruise Main dash switch toggles the "Cruise Enable/Disable" functions in the Link G4+ ECU. This is due to the mechanical design of the switch (i.e., pressing either button switches both poles simultaneously), and the design of the Link G4+ cruise control software.

Title Link G4+ ECU Wiring Installation Schematic, 1993 Mazda RX7		
Author Peter W. Morel		
Subtitle: Modifications to the OEM Cruise Control Schematic		
File C:\Users\Peter W. ... FD Schematic-Rev4.0.dsn	Document FD3S-001	
Revision 4.0	Date 8 December 2023	Sheets 7 of 10

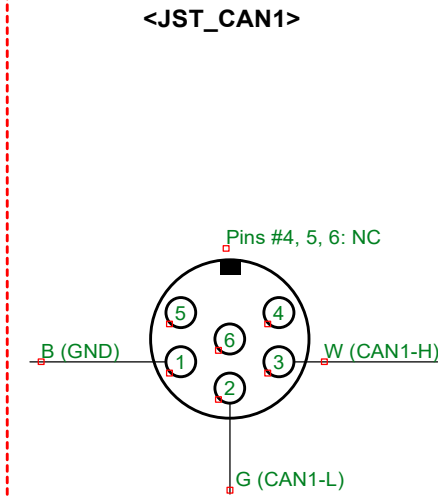
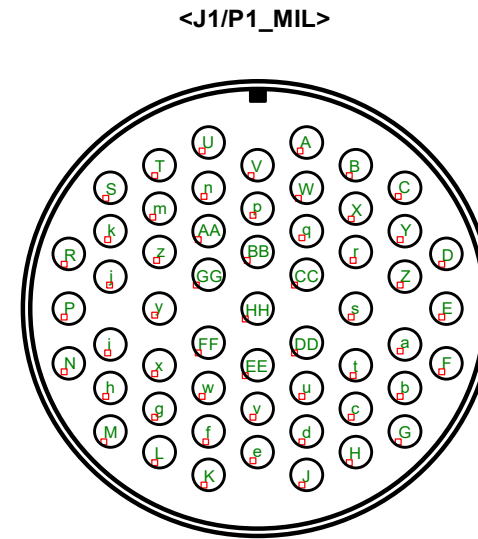
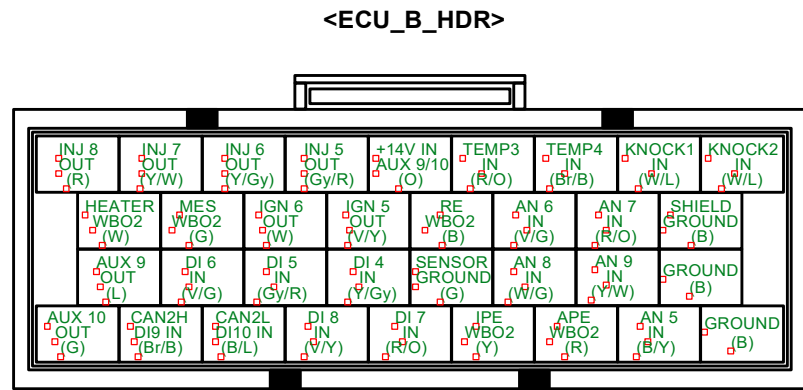
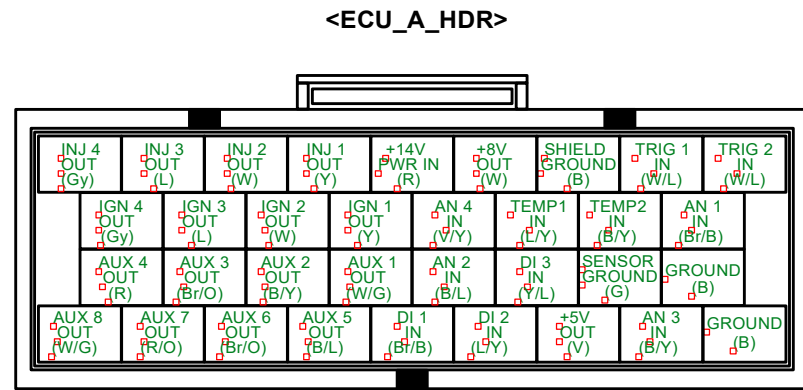

Notes:

1. Diagram convention: All wire colors and terminal designations for connectors are shown as they are viewed from the wiring harness side of the connector shell, unless noted otherwise. "NC" denotes "No Connection".
2. Connector identification nomenclature: <XXX#_TEXT> The 2 or 3 character "XXX" code denotes the series of connector used; "#" represents the number of conductors, and "TEXT" denotes an abbreviated description of the connector's function in the circuit. Examples follow:
 - 2a. <DTM#_TEXT> = Deutsch DT-Miniature series; Example: <DTM6_IGN> denotes a 6 pin DTM connector in the Ignition sub-harness.
 - 2b. <DTP#_TEXT> = Deutsch DT-Power series; Example: <DTP4_PWR_IN> denotes a 4 pin DTP connector in the power distribution sub-harness.
 - 2c. <WP#_TEXT> = Weather Pack connector; Example: <WP3_CRUISE> denotes a 3 pin Weatherpack connector in the Cruise Control sub-harness.
 - 2d. Connectors unique to the device they connect to are denoted as follows: <NAME-#>, where "NAME" denotes the device; "#" denotes the number of conductors. Example: <RX8APS-6> denotes the RX8 Accelerator Pedal Sensor 6 pin connector.
3. All OEM Mazda connectors shown in this drawing are referenced IAW the same nomenclature designations used in the Mazda FSM, Section Z, Schematic Diagrams, e.g., <X14>, <B1-01>, etc.
4. Connector gender identification nomenclature: All male connectors are identified by a (P) for Plug following the connector name, e.g., <DTM6_OMP>, (P). All female connectors are identified by a (R) for Receptacle following the connector name, e.g., <DTM6_OMP>, (R).
5. All two pin connectors that are not connected to polarized devices are intentionally omitted from this diagram. This includes all fuel injectors, 2 terminal temperature sensors, and solenoids. Refer to the schematic diagram for wire colors on these connectors; schematic provides sufficient information for electrical testing and troubleshooting of these circuits.
6. The <ECU_A_HDR> and <ECU_B_HDR> connectors specified for the Link G4+ ECU are AMP Super Seal 1.0 Series, 34 way connectors, and both are female receptacles. The only salient difference is in the keying, as shown on this drawing by the filled-in black rectangles, and differentiated by part dash numbers. Replacement connector backshell part numbers are as follows: <ECU_A_HDR> = TE Connectivity #4-1437290-0; <ECU_B_HDR> = TE Connectivity #4-1437290-1.
7. Replacement female terminals for <ECU_A_HDR> and <ECU_B_HDR> are the same. For 18AWG wire applications, use TE Connectivity part #3-1447221-3. For 20AWG wire applications, use TE Connectivity part #3-1447221-4.
8. Pin designations and wire colors for the <ECU_A_HDR> and <ECU_B_HDR> are viewed from the wire side of the harness (or into Link G4+ ECU header), with keying as shown.
9. ECU terminal identification nomenclature for <ECU_A_HDR> and <ECU_B_HDR> shown above are consistent with the schematic diagram, and Link G4+ Fury manufacturer's documentation.

Notes (Continued):

10. Wire colors for the <ECU_A_HDR> and <ECU_B_HDR> terminals are identified in brackets, following the terminal identification. Example: INJ 4 OUT (Gy) identifies a Gray wire on the Injector #4 Output terminal.
11. The <J1/P1_MIL> designates a 55 way MIL SPEC firewall bulkhead connector pair. The engine compartment side of this pair is a plug, IAW specification MS3476L22-55P, and the firewall bulkhead side is a receptacle, IAW specification MS3470L22-55S.
12. Pin/socket arrangement and identification nomenclature for <J1/P1_MIL> is schematically illustrated on this drawing for service and installation purposes, it is not an exact, scale representation of the item configuration. Scale drawings and specifications of the connector items are IAW MS3470L22-55S and MS3476L22-55P item drawings. Note that upper case letters I, O and Q, and lower case letters I, and o are not used IAW this specification.
13. The filled in black rectangle in the <J1/P1_MIL> drawing schematically represents the keying utilized.
14. Replacement terminals for <J1/P1_MIL> shall be IAW specifications M39029/4-110, male pins for the plug side, and M39029/5-115, female sockets for the receptacle side. These terminals are commonly referred to as size 20 pins or sockets, and they accept wire gauges from 18AWG to 20AWG, when using M22759/32 Tefzel insulated wire.
15. Specialized tooling is required to insert and remove pins/sockets from <J1/P1_MIL>. A suitable low cost plastic tool made IAW military specification M81969/14-02 is readily available from multiple sources. Note however that this plastic tool is not durable and is considered disposable, thus re-pinning all terminals on <J1/P1_MIL> typically consumes at least 5 of these tools.
16. Revision 4.0 added the <JST_CAN1> connector. The filled in black rectangle in the <JST_CAN1> drawing schematically represents the keying utilized. <JST_CAN1> was procured as a pre-assembled connector pigtail assembly, with the wire colors and functions as indicated on this sheet. Incorporating this connector enables access to the dedicated CAN1 port on the Link G4+ ECU for CAN bus instrumentation, and frees the dual-purpose DI9/CAN2-H and DI10/CAN2-L pins on <ECU_B_HDR> for dedicated Digital Input usage. The <JST_CAN1> connector pigtail assembly connects to the existing CAN bus wiring as detailed on Sheet #3 of this drawing.

Title Link G4+ ECU Wiring Installation Schematic, 1993 Mazda RX7		
Author Peter W. Morel		
Subtitle Connector Diagrams, Sheet 1 of 3		
File C:\Users\Peter W. ... FD Schematic-Rev4.0.dsn	Document FD3S-001	
Revision 4.0	Date 8 December 2023	Sheets 8 of 10

<DTM12_X1000>, (R)
OEM (F) Harness Side, Wires
De-Pinned From <B1-01>(F)

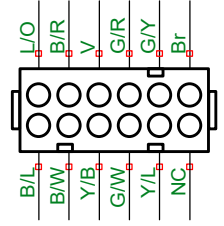

<DTM8_X05/14>, (R)
Link G4+ ECU Harness Side

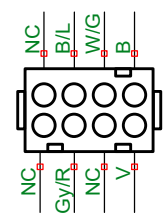

<DTM8_TRANS>, (P)
Connects to <DTM6_TRANS>(R)

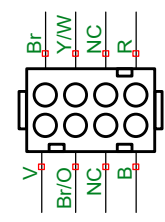

<X05>, (P)
Link G4+ ECU Harness Side



<X14>, (P)
Link G4+ ECU Harness Side



<DTM8_SP_IO>, (R)
Link G4+ ECU Harness Side

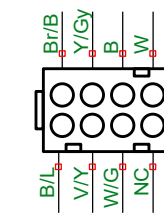

<DTM8_SP_IO>, (P)
Wires to <DTM2_MS>, (R)

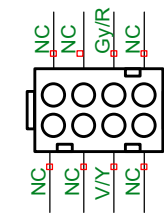

<DTM12_X1000>, (P)
Link G4+ ECU Harness Side

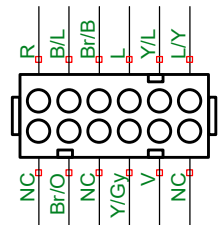

<DTM8_X05/14>, (P)
Wires To OEM (D) Harness, <X14>(P)
and OEM (F) Harness, <X05>(P)

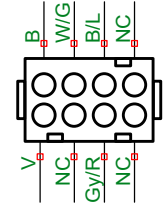

<DTM8_TRANS>, (R)
Wires To OEM (D) Harness, <X14>(P)
and OEM (F) Harness, <X05>(P)

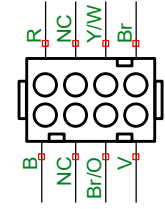

<X05>, (R)
OEM (F) Harness Side



<X14>, (R)
OEM (D) Harness Side



<GM6_DBW>, (R)
Pigtail Assembly, Connects to
<DTM6_DBW>, (P)

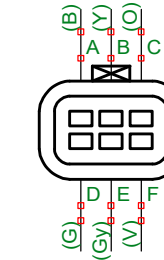

Note:
**Replacement <GM6_DBW> pigtail
assembly wire colors as indicated;
connect terminals A to F to
<DTM6_DBW> (P) as indicated.**

<DTM6_IGN>, (R)
Link G4+ ECU Harness Side

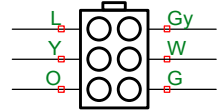

<DTM6_IGN>, (R)
IGN Harness Side, to IGN-1A Coils

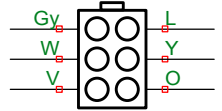

<DTM6_TRANS>, (R)
Connects to <DTM8_TRANS>,(P)

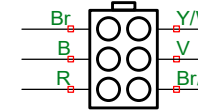

<DTM6_TRANS>, (P)
Wires to OEM Connectors
<B1-50>; <F3-07>; <C1-08>

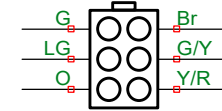

<RX8APS-6>, (R) Connector
Terminals; Wires from
<DTM4_APS> (P) Connector

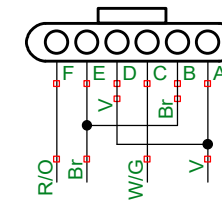

<DTM6_DBW>, (R)
Link G4+ Harness Side

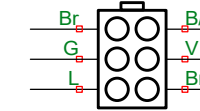

<DTM6_DBW>, (P)
Connects to <GM6_DBW> Pigtail
Wires/Terminals as indicated

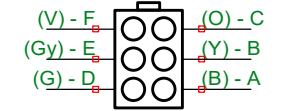

<DTM6_EFANS>, (R)
OEM (F) Harness Side

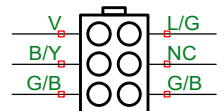

<DTM6_EFANS>, (P)
To E-Fan Relay Box

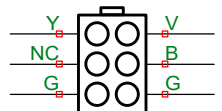

<WBO2-6>, (R)
Link G4+ ECU Harness Side

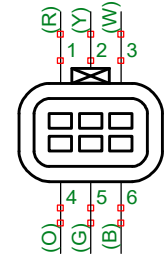

<WBO2-6>, (P)
LSU 4.9 WBO2 Sensor Connector

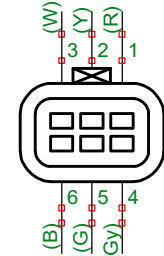

<DTM4_APS>, (R)
Link G4+ ECU Harness Side

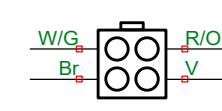

<DTM4_CAN>, (R)
Link G4+ ECU Harness Side

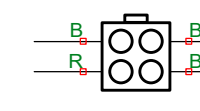

<DTM4_CAN>, (P)
Cable to GaugeART CAN Gauge

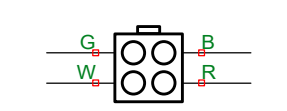

<FP-3>, (R)
Fuel Pressure Sensor Connector

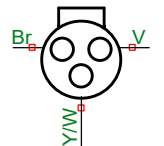

<OP-3>, (R)
Oil Pressure Sensor Connector

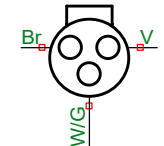

<FF-3>, (R)
Flex Fuel Sensor Connector

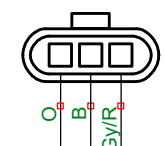

<DTM3_MAP>, (R)
Wires from OEM (F) Harness,
<X05> (R) and <DTM12_X1000> (R)

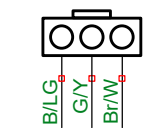

<DTM4_APS>, (P)
Wires to <RX8APS-6> (R)

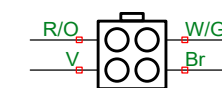

Title Link G4+ ECU Wiring Installation Schematic, 1993 Mazda RX7		
Author Peter W. Morel		
Subtitle: Connector Diagrams, Sheet 2 of 3		
File C:\Users\Peter W. ... FD Schematic-Rev4.0.dsn	Document FD3S-001	
Revision 4.0	Date 8 December 2023	Sheets 9 of 10



<DTP4_PWR_IN>, (R)
Power Harness Wires,
from ECU Fuse Block

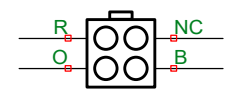

<DTP4_PWR_IN>, (P)
Power Input Pigtail,
Relay Panel Assy.

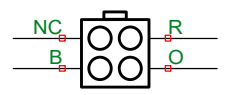

<DTP2_ECUPWR>, (R)
Power Out Pigtail from
Relay Panel Assy.

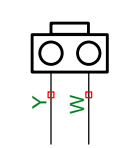

<DTP2_ECUPWR>, (P)
Power Input Pigtail,
Link G4+ ECU Harness

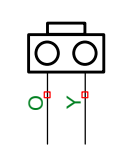

<DTP2_FP1>, (R)
Fuel Pump Power Out Pigtail,
from Relay Panel Assy.

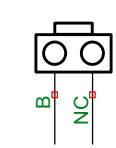

<DTP2_FP1>, (P)
to Fuel Pump Connector,
<DTP2_FP2, (R)>

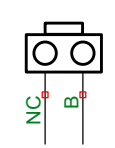

<DTP2_FP2>, (R)
Power from <DTP2_FP1>, (P);
Ground from <JC12>

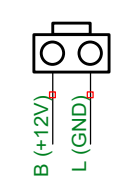

<DTM6_OMP>, (R)
Link G4+ ECU Harness Side

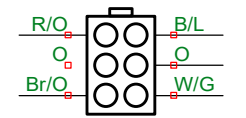

<DTM6_OMP>, (P)
OMP Side Pigtail

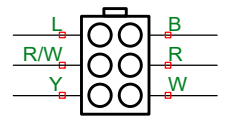

<DTM3_OMP>, (R)
Link G4+ ECU Harness Side

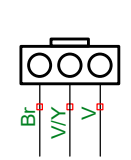

<DTM3_OMP>, (P)
OMP Side Pigtail

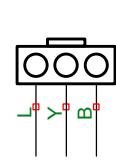

<WP2_INTANK>, (P)
Power/GND Pigtail, from
Fuel Pump

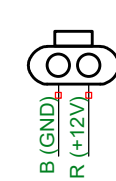

<WP2_INTANK>, (R)
Power/GND Pigtail, connects
to <WP2_INTANK>, (P)

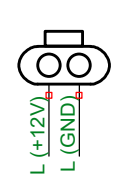

<DTP2_FP2>, (P)
Power/GND Wires to In-Tank
Connector <WP2_INTANK>, (R)

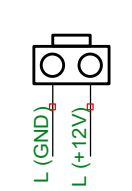

<DTP2_FANPWR>, (R)
60A Fused PWR IN to E-Fan Relay
Box, from OEM (F) Harness

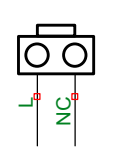

<DTP2_FANPWR>, (P)
E-Fan Relay Box PWR IN Pigtail

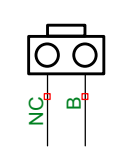

<DTP4_EFAN1>, (R)
Cable from EFAN Relay Box

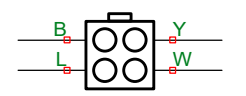

<DTP4_EFAN1>, (P)
Pigtail to Fan Motor 1

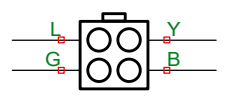

<DTP4_EFAN2>, (R)
Cable from EFAN Relay Box

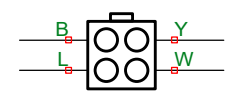

<DTP4_EFAN2>, (P)
Pigtail to Fan Motor 2

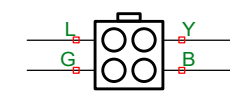

<WP3_BST>, (R)
Boost Solenoid Connector

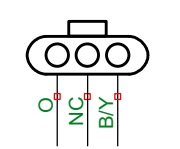

<DTM4_CRUISE>, (P)
Link G4+ ECU Harness Side

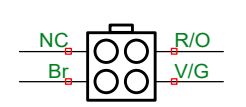

<DTM4_CRUISE>, (R)
Wires to <WP3_CRUISE>, (R)

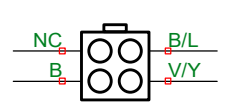

<DTM3_RLY>, (R)
Link G4+ ECU Harness Side

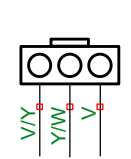

<WP5_L1>, (R)
IGN-1A Coil, Leading #1 Rotor

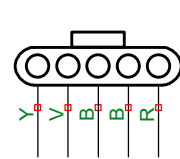

<WP5_T1>, (R)
IGN-1A Coil, Trailing #1 Rotor

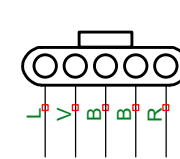

<WP5_L2>, (R)
IGN-1A Coil, Leading #2 Rotor

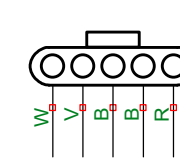

<WP5_T2>, (R)
IGN-1A Coil, Trailing #2 Rotor

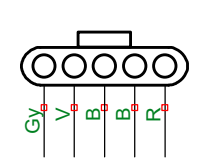

<WP3_CRUISE>, (P)
Wires to OEM <Q-01> Connector

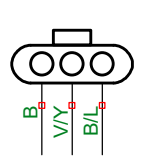

<WP3_CRUISE>, (R)
From <DTM4_CRUISE>, (R)

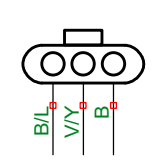

<DTM3_RLY>, (P)
Relay Panel Pigtail to ECU Harness

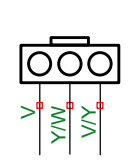

<DTM2_MS>, (R)
Connects to <DTM8_SP_IO>, (P)
User Input Mode Sw. Sub-Harness

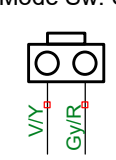

<DTM2_MS>, (P)
Connects to User Input Sw. 1 and 2
User Input Mode Sw. Sub-Harness

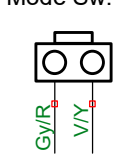

Title Link G4+ ECU Wiring Installation Schematic, 1993 Mazda RX7		
Author Peter W. Morel		
Subtitle: Connector Diagrams, Sheet 3 of 3		
File C:\Users\Peter W. ... FD Schematic-Rev4.0.dsn	Document FD3S-001	
Revision 4.0	Date 8 December 2023	Sheets 10 of 10