

## Fuel pump rewire for a 93-95 Mazda Rx7

Notes about installation: Bosch relay used, please check your terminals for exact colors and numbers. Also fuse size may vary depending on your fuel pump needs. This example is using a Supra TT fuel pump Denso part number 951-0014 or Denso kit number 950-0155. For a stock fuel pump you could use a 20 amp fuse in place of 25 amp.

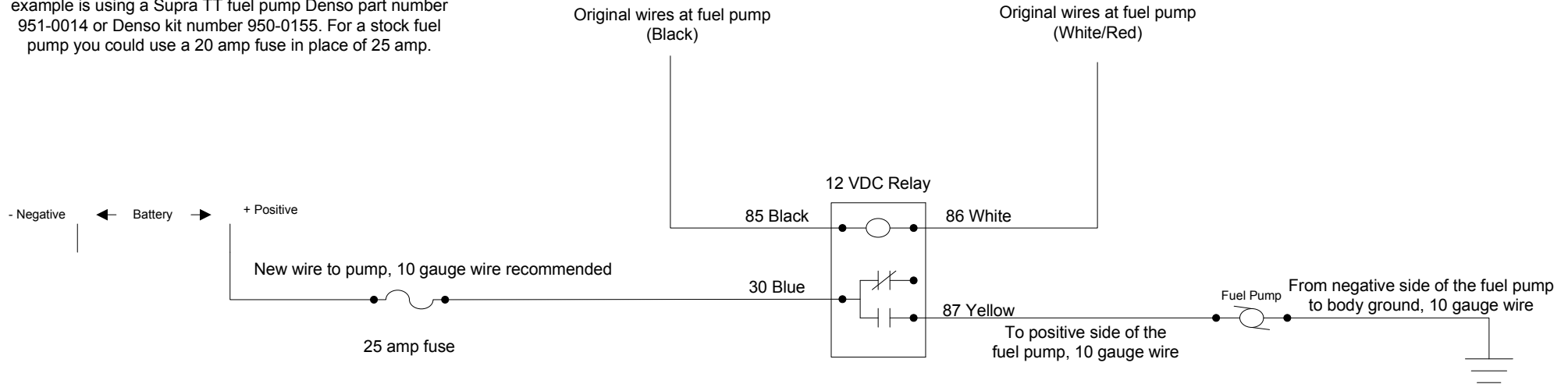

Drawn by RotaryBuddha for  
[www.rx7club.com](http://www.rx7club.com)