

Series 5 Anti-Theft and Flasher CPU Recap and Repair 2024

By ProfessionalPyroman

This guide is written to inform owners on the means to suitably repair the Anti-theft and Flasher CPU in the Series 5 Mazda RX-7. This document may be applicable to additional model series, but the work detailed herein is based on a Series 5 Turbo II CPU. CPU provided by Turbonut, photos and work provided by ProfessionalPyroman.

Background

The Series 5 Rx7 was produced from 1989-1991 and is currently 35 years old. It follows that the condition of these vehicles has deteriorated over this time. Some deterioration is due to wear and tear and some due to aging components. The electronic modules in these vehicles, while fairly robust in construction, are subject to this deterioration as well. Common modes of failure among these electronic modules are the failure and leakage of electrolytic capacitors, along with its associated circuit board rot, breakage of diodes, and burnout of transistors. Many of the components used in our car's electronics have well exceeded their average lifespan, some doing so over ten years ago. The more time elapses without preventative maintenance or repair, the more likely that irreparable damage will appear. With the availability of these electronics modules being limited to old stock or salvage, the spoilage of these electronics is a common but preventable occurrence. This also includes desert and well-kept one-owner vehicles.

Introduction

The Anti-Theft Unit and Flasher CPU in the Series 5 Rx7 covers a wide range of functions. As the name suggests, it covers the functions of the flashers and the anti-theft functions of the car. There are also other functions such as interior light control, power locks, warning lights, starter cut relay, and the much-adored beep-beep beep-beep beep-beep... The functions of this unit are detailed in the Factory Service Manual on pages T-78 through T-84 in the Body Electrical section as well as the associated wiring diagram. This document only covers the recap and repair of these units, and a detailed breakdown will be released in a later document.

Signs that a CPU unit has failed include the absence of beeping, failure of interior lights to come on when the doors are opened, and the one-time initiation of the car alarm for no apparent reason followed by the failings listed prior. The Factory Service Manual has procedures to determine if the CPU has failed, or if an input is not behaving correctly.

Inspection and Repair

If the CPU unit has been proven faulty by failing the tests provided in the FSM, the unit must be repaired or replaced. Given the low inventory and the fact that even an old-stock item has components with the same age as the failed units in the cars, repair or preventative maintenance is recommended. The CPU unit is contained in a small, black, plastic case, plugged into the wiring harness near the fuse box in the driver's side footwell, highlighted in Figure 1. Removal is simple. There are 3 harness plugs that go into the unit (4 for Canadians), and a 10mm nut that holds the top of the unit onto a stud. After removing the plugs and nut, the unit can be lifted up and out since the bottom tab is slotted in to hold the bottom of the unit.

T THEFT-DETERRENT SYSTEM

THEFT-DETERRENT SYSTEM

STRUCTURAL VIEW

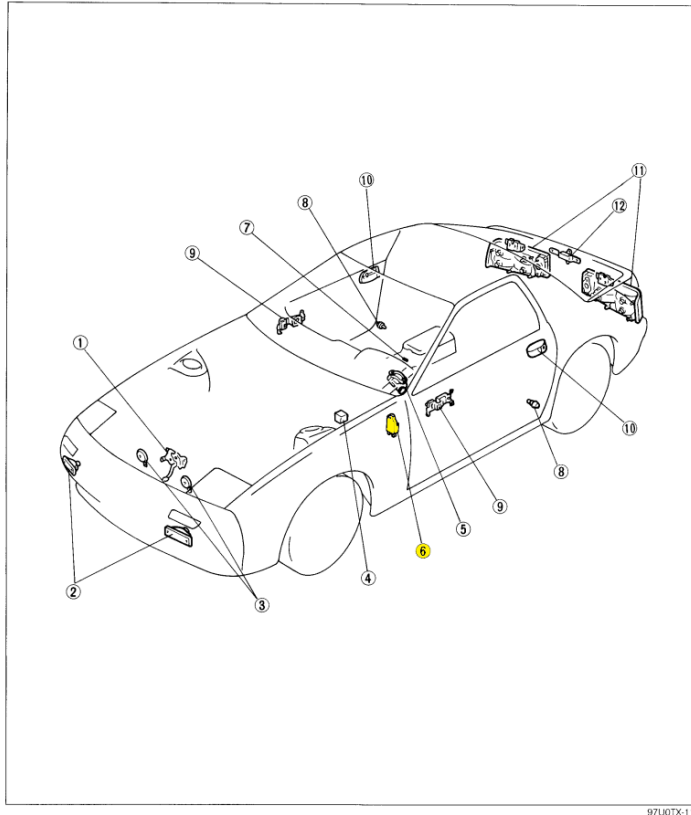

- | | |
|--|---|
| 1. Hood switch | 7. Security lamp |
| 2. Hazard warning lights | 8. Door switches |
| 3. Horns | 9. Door lock switches |
| 4. Starter cut relay | 10. Door key cylinder switches |
| 5. Ignition switch & key reminder switch | 11. Rear hatch (or trunk) switches |
| 6. Theft-deterrent control unit (in CPU) | 12. Rear hatch (or trunk) key cylinder switch |

T-78

Figure 1 CPU and Flasher Unit Location

Outside the car, the unit can be opened and repaired. An initial inspection of the unit includes checking to see if there are corroded or broken pins on the plug receptacles. Following this inspection, the unit can be opened up and examined. The unit shown in this document is a US Turbo II unit and only contains two circuit boards. The CPU assembly shown in Figure 2 consists of the CPU board that controls the functions described above, and the flasher relay board that clicks the hazard and turn signal lights. Note that in the illustration in Figure 2 taken from the FSM, there is a typo where labels C and D are swapped from what they should be.

Simple tools are needed to open up the CPU casing. There is a screw holding the back cover over the CPU board, and a screw holding the bottom cover over the flasher board. After removing these screws, use a thin shim to dislodge the tabs holding the covers on. The bottom cover should pull straight out. The back cover requires an upward sliding motion once the tabs are dislodged to remove it.

T CENTRAL PROCESSING UNIT (CPU)

CENTRAL PROCESSING UNIT (CPU)

REMOVAL AND INSTALLATION

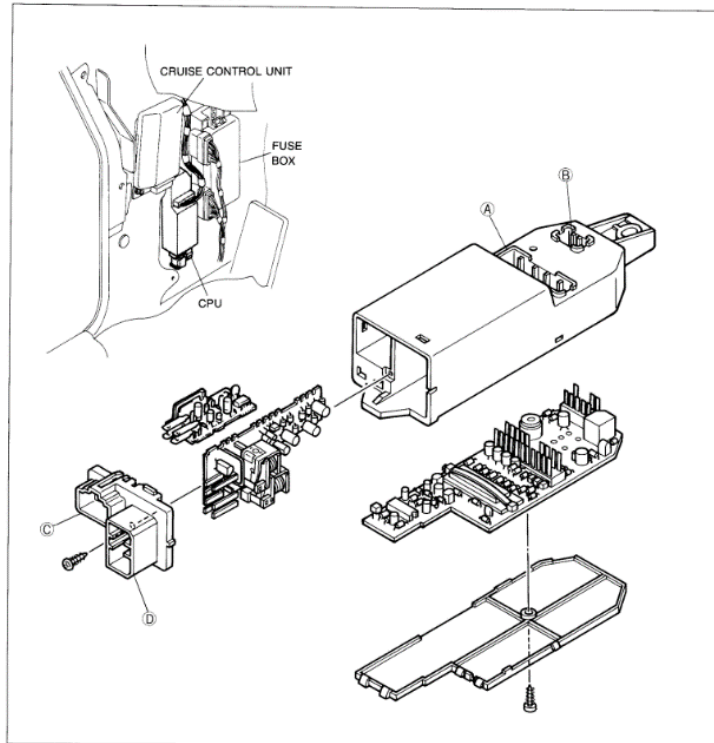

97UJTX-035

Function	Connector	U.S.A.	Canada
Turn and hazard unit	C	○	○
Burglar buzzer	B	○	○
Passive belt warning	A	○	X
Seat belt timer & buzzer	A	○	○
Key reminder buzzer	A	○	○
Key illumination timer	A	○	○
DRL unit	D	X	○

T-32

Figure 2 Flasher and CPU Layout

Once the covers have been removed, the circuit boards can then be removed from the case. The CPU board simply slides out, while retaining the pins on the circuit board. If the board gets stuck, simply use a plastic pusher like a pen or something similar and gently push the pins out through the sockets. Once removed, both circuit boards can be examined (Figures 3 and 4).

The first board examined is the CPU board. This is where most of the failures have been found by the Author when working on these units. The most common observed failure for these units is failed electrolytic capacitors. The capacitors leak over time, or all at once, spreading corrosive electrolyte across the printed circuit board. This failure has been present at varying degrees in all of the units that the Author has worked on.

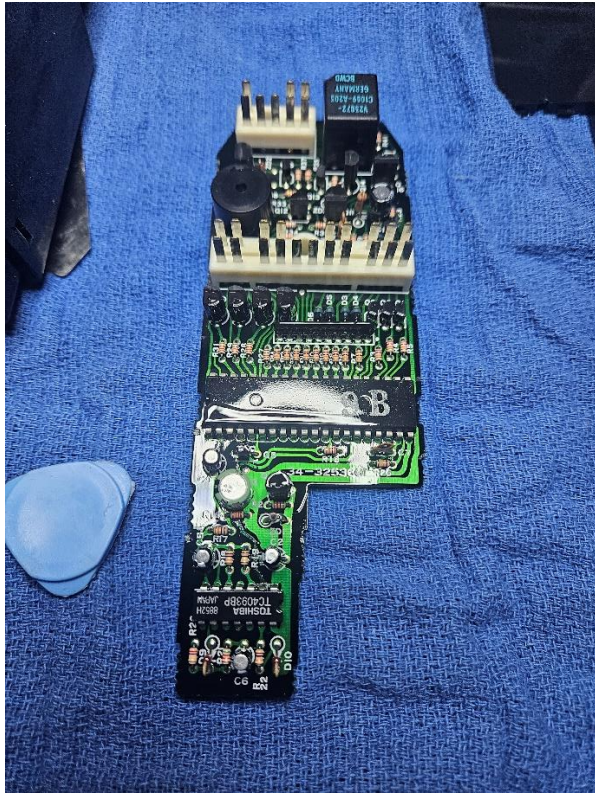

Figure 3 CPU Board



Figure 4 Flasher Relay Board

There are six electrolytic capacitors on the CPU board, labeled C1-C6 (Figure 5). C7 is ceramic and does not present a risk of failure. A list of capacitor values is included at the end of this document. The first problem area is capacitor C1 and its surrounding components. This is the main power filter capacitor. It takes 12v power from the battery and filters it for the 5v regulator and other components. This area of the circuit board has been damaged in every unit that the Author has worked on. This area was also the main focus of the repair on this unit.

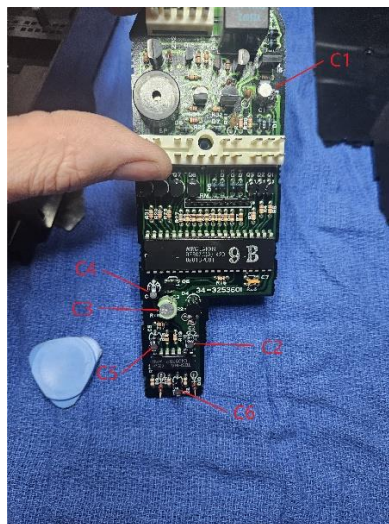

Figure 5 Electrolytic Capacitor Locations

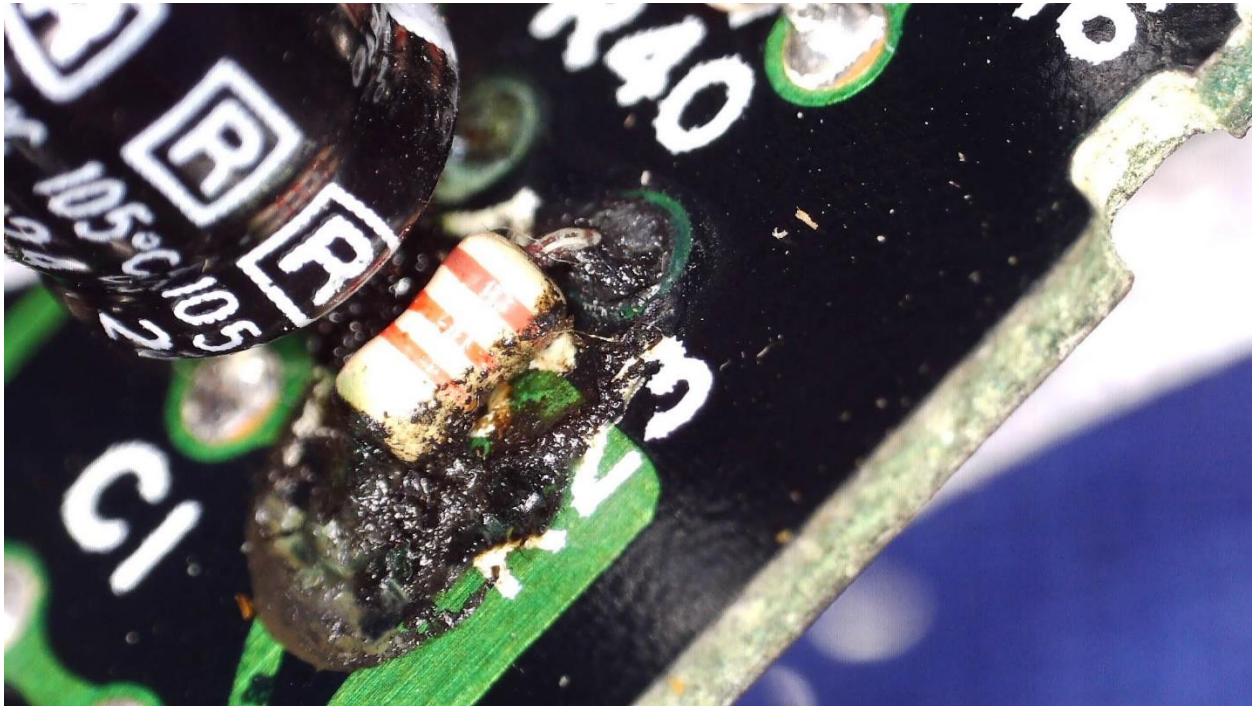

Figure 6 Failed C1 Capacitor and Corroded R23

Figure 6 shows a zoomed in view of the afflicted area. In the case of this CPU C1 failed, which by itself would not cause the unit to cease function but damage to the circuit board also contributed to the overall failure of the unit. C1 was desoldered and removed from the board to assess the damage to the underlying circuits, shown in Figure 7. In Figure 7, the damage to the underlying circuit board is easily shown. Where there was originally a solid copper trace under C1, a large corroded pit can be found. The copper from that portion of the trace was eaten away by the leaked electrolyte. In addition, substantial corrosion covered R23 enough that the resistor was eaten into two parts and crumbled upon removal. The area was cleaned and the traces tested for continuity, shown in Figure 8.

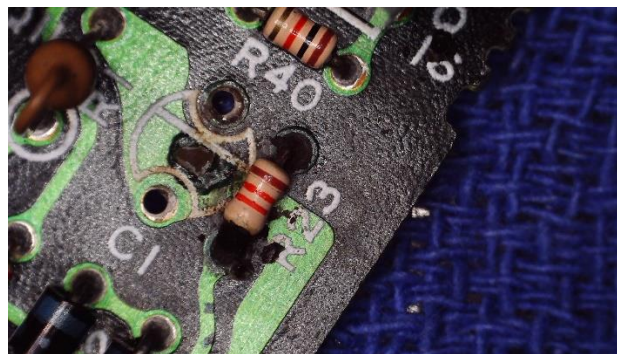

Figure 7 Damage Beneath C1



Figure 8 Damaged C1 and R23 Traces

The damage in this case was manageable. There was enough of the large trace left that battery voltage could pass from R1 to the 5v regulator easily. There was damage on the plated thru-holes for C1 and R23. This was not a concern for component C1 as the upper hole, near R40 does not connect to this side of the circuit board, but the ground plane on the back side of the board. The same is true for the upper hole on R23. There was additional work needed on R23 however. The lower PTH was corroded enough that a connection could not be made with the harness pin connector. This resistor is responsible for draining voltage away from the pin when the key is removed from the ignition cylinder. The Author suspects that the severing of this trace by corrosion is what causes the car alarm to go off upon CPU failure because the microcontroller may view this event as a car alarm trigger. More testing will be needed to confirm this.

The copper in the trace surrounding the lower PTH was then exposed with a craft blade to provide material to solder to. This allowed the 1.2k ohm resistor to be reconnected to it's respective harness pin with a large fillet of solder, shown in Figure 9. In other units, where the damage to this trace was more severe, a jumper wire was soldered on the back side of the board from the resistor leg to the pin, bypassing the damaged pcb trace.



Figure 9 Large Solder Fillet for R23

This was the repair for the C1 area. C2, near the 5v regulator was the next capacitor to be replaced. It had also leaked and was corroding a nearby trace, shown in Figure 10.

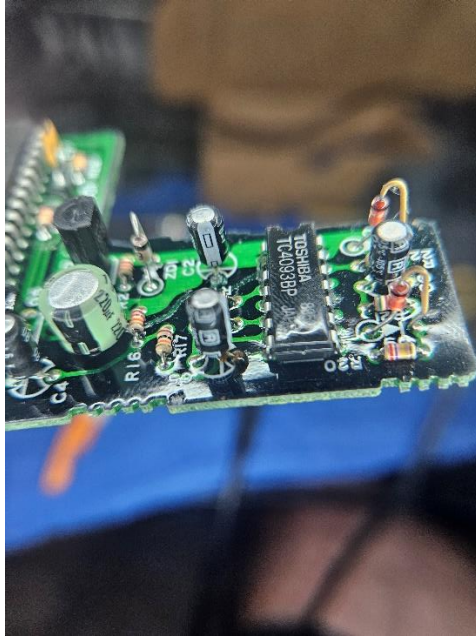

Figure 10 C2-C6 Leakage and Corrosion

In Figure 10, capacitors C2-C6 can be seen, as well as a darker trace next to C2 running from the Toshiba NAND trigger package to the NEC uPD7507 microcontroller. C2 had leaked similar to C1 and was starting to corrode this trace as well. After removal of C2-C6, the corroded traces were inspected and still found to be intact. If the damage worsens, jumper wires will be used here as well. With all the electrolytic capacitors replaced on this board, and connections verified, it was secured back inside the CPU case, and the flasher relay board was inspected.

The flasher relay board, shown in Figure 4, is a simple design. The circuit board is only printed on the bottom side. It is possible that by having the printed circuits on the bottom, this inhibits corrosion from becoming as bad as that found on the double-sided CPU circuit boards. The Author has found failed capacitors on flasher boards, but no noticeable corrosion. There are only three electrolytic capacitors to replace on this board, shown in Figure 11. Replacement is fairly straightforward, with the only standout being that C2 is a bi-polar capacitor. If this is replaced with a regular electrolytic capacitor, it will adversely affect the function of the hazards and turn signals.

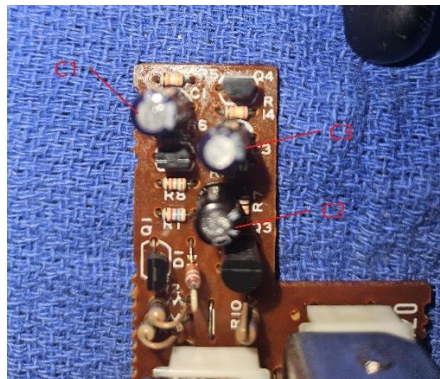

Figure 11 Flasher Electrolytic Capacitor Locations

After the flasher capacitors were replaced, the flasher board was also inserted back in the case and the covers replaced. The CPU unit was placed into the Author's Series 5 TII and tested according to the procedures in the FSM, pages T-80 through T-84, where it passed all tests.

Conclusion

While each unit will require individual assessment to determine the level of repair needed, in most cases the Author has found that a rework of the C1 area, as well as a full replacement of electrolytic capacitors is most often the needed repair. This concludes the scope of this document. A list of electrolytic capacitors and their values for the CPU and flasher boards can be found below.

Flasher

C1	Rubicon	25v	22uf	
C2	Panasonic	16v	10uf	Bi-Polar
C3	Rubicon	50v	3.3uf	

CPU

C1	Rubicon	16v	47uf
C2	Rubicon	16v	10uf
C3	Rubicon	10v	220uf
C4	Rubicon	16v	10uf
C5	Rubicon	16v	10uf
C6	Rubicon	16v	10uf