

MAZDA

Mazda RX-7

Owner's Manual

ΕΓΧΕΙΡΙΔΙΟ ΧΡΗΣΗΣ
ΕΛΛΗΝΙΚΗ ΕΚΔΟΣΗ

8899

Form No.8899-LH-89C

©1989 Mazda Motor Corporation

Printed in Japan 90-09 C

1 IMPORTANT PRELIMINARY INFORMATION

LETTER FROM AUTO LINKS WHICH WILL HELP ENDS FOR
YOUR SAFETY AND PERFORMANCE

**IMPORTANT PRELIMINARY
INFORMATION**

1

BEFORE DRIVING YOUR VEHICLE

2

STARTING AND OPERATING

3

**SPECIAL AND EMERGENCY
OPERATING CONDITIONS**

4

**APPEARANCE CARE- REQUIRED
OWNER'S MAINTENANCE**

5

MAINTENANCE

6

SPECIFICATIONS

7

INDEX

8

67U0-0030E

NOTE

The number above each explanation in this manual (e.g. 67U2-0170E) is not directly connected with the contents of this manual.

1	IMPORTANT INFORMATION
2	BEFORE DRIVING YOUR VEHICLE
3	STARTING AND OPERATING
4	SPECIAL AND EMERGENCY OPERATING CONDITIONS
5	OWNER'S MAINTENANCE ATTENDANCE CARE - REQUIRED
6	MAINTENANCE
7	SPECIFICATIONS
8	INDEX

NOTE
 The information in this manual is for general information only. It is not intended to be used as a substitute for the vehicle's operating instructions. Always use the operating instructions that come with the vehicle.

1. IMPORTANT PRELIMINARY INFORMATION

67U1-0010E

A LITTLE ATTENTION TO MAINTENANCE WILL HELP ENSURE YOUR VEHICLE'S SATISFACTORY PERFORMANCE.

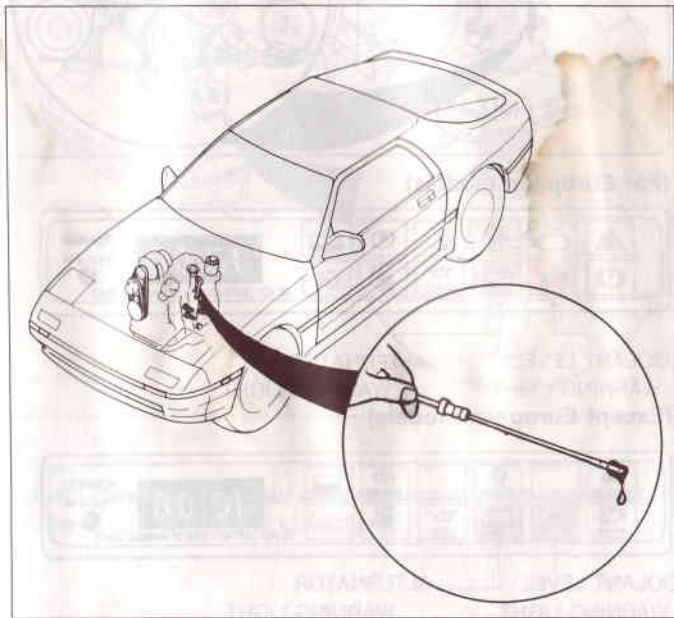

57A1-0020E

Check the engine oil level.
Refer to ENGINE OIL LEVEL in Section 6.

NOTE

It is normal for your rotary engine to consume a slight amount of oil, since the gas seals are lubricated by metering oil into the combustion chambers. The oil consumption rate varies depending on the driving conditions (e.g. hard driving, mountain driving, on a highway, in a city, in heavy traffic, and in varying traffic).

(For European models)



OIL LEVEL WARNING LIGHT

(Except European models)



OIL LEVEL WARNING LIGHT

67U1 0030E

Check the coolant level.

Refer to **ENGINE COOLANT LEVEL** in Section 6.

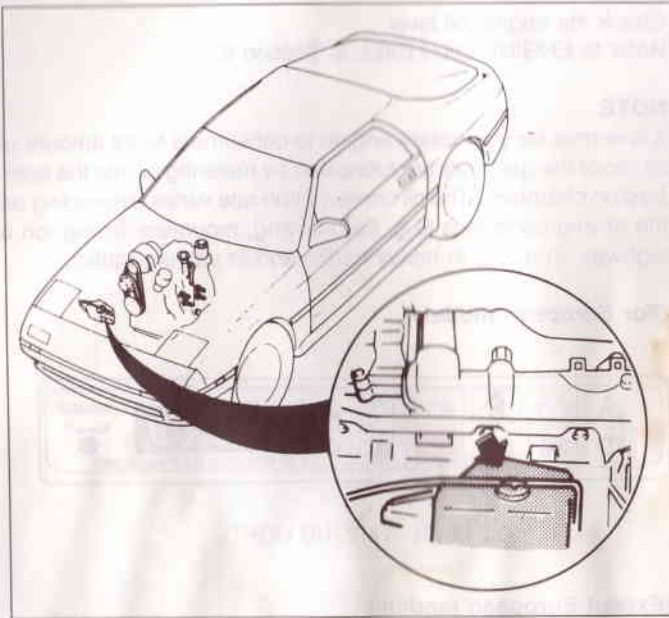

Do not remove the thermostat.

If removed, overheating will result.

67U1 0040E

Check the fan belt tension and condition.

Refer to **CHECKING BELT TENSION** in Section 6.

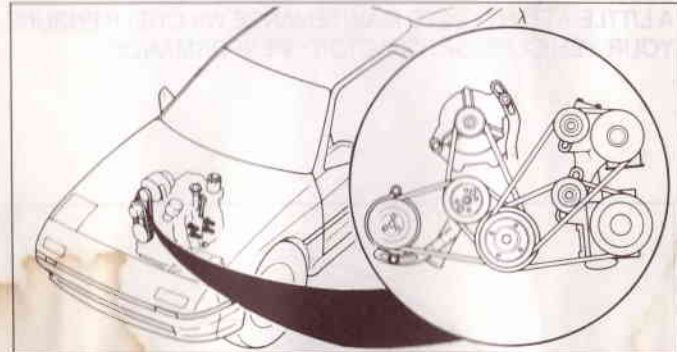

(For European models)



COOLANT LEVEL
WARNING LIGHT

ALTERNATOR
WARNING LIGHT

(Except European models)



COOLANT LEVEL
WARNING LIGHT

ALTERNATOR
WARNING LIGHT

67U1-0050E

Use specified spark plugs.
Refer to Recommended spark plugs in Section 6.

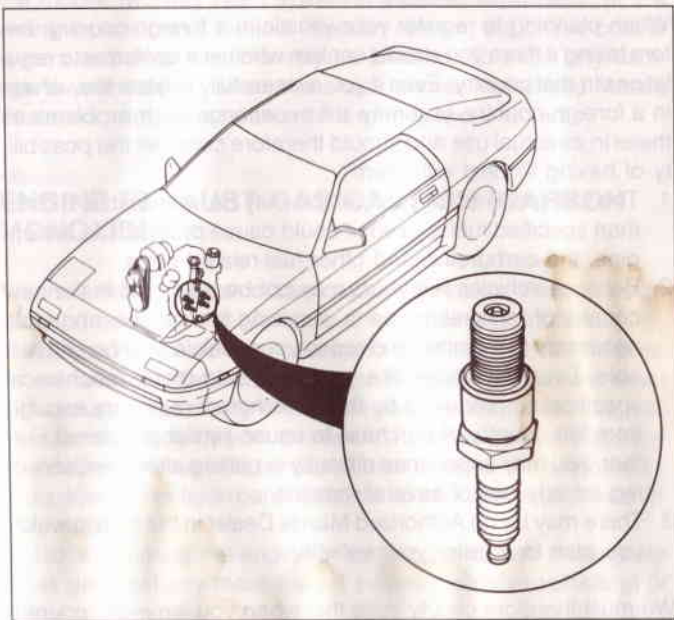

Use a genuine Mazda air cleaner element or its equivalent.
Refer to AIR CLEANER in Section 6.

67U1 0060E

MAINTENANCE AND WARRANTIES

Your new Mazda rotary engine is a unique product. Protect its high performance by following both the operating instructions and the maintenance instructions set forth in this owner's manual.

Your rotary engine is covered by an excellent warranty. Read and understand the written warranty completely and comply with the recommended maintenance schedules.

Between regular servicing periods, pay careful attention to oil and coolant levels and to proper fan belt tension.

While operating your Mazda, observe your instrument panel gauges and indicator lights. Compliance with the above instructions is essential for the prevention of damage to your high-performance Mazda engine.

If you do operate your Mazda when the engine is overheated or oil or coolant is low, serious damage to your engine may result.

In the event of any unusual operating conditions, such as overheating, you should stop your vehicle and promptly contact your nearest Authorized Mazda Service facility (or other qualified maintenance establishment.).

Thank you.

FUEL RECOMMENDATION

(For European models)

Use only unleaded gasoline with an Octane Rating of at least 95 Research Octane Number.

(Except European models)

Your vehicle will operate efficiently on loaded or unleaded regular grade gasoline.

REGISTERING YOUR VEHICLE IN A FOREIGN COUNTRY

When planning to register your vehicle in a foreign country, before taking it there you should confirm whether it conforms to regulations in that country. Even if you successfully register the vehicle in a foreign country, you may still experience such problems as these in its actual use and should therefore consider the possibility of having to deal with them.

1. The fuel specified for your vehicle may be unavailable. If other than specified fuel is used, it could cause problems to the engine, the carburetor, and other fuel-related parts.
2. Because vehicles like yours may not be marketed in the new country of registration, parts, servicing techniques, and tools necessary to maintain and repair your vehicle may be unavailable. Even if vehicles like yours are sold there, mechanical specifications required by the government may vary enough from the country of purchase to cause similar problems. Further, you may experience difficulty in getting after-sales servicing for any one of several reasons.
3. There may be no Authorized Mazda Dealer in the area in which you plan to register your vehicle.

We must therefore clearly state that when you leave the country in which you purchased your Mazda as a new vehicle and register it in another country, troubles arising from the use of fuel other than specified fuel are not subject to manufacturer's warranty. Further, we cannot assume any responsibility for problems that result from unsatisfactory service or lack of service because of the reasons outlined above.

MOBILE TWO-WAY RADIO SYSTEM

If a mobile two-way radio system is installed improperly, or if a wrong type is used, the fuel injection system, the cruise control system and other systems may be affected. To avoid any damage to your vehicle, be sure to check with an Authorized Mazda Dealer for proper installation of a mobile two-way radio.

ENGINE EXHAUST GAS CAUTION (CARBON MONOXIDE)

Engine exhaust gases contain carbon monoxide. Though colorless and odorless, it is dangerous, even lethal, if inhaled.

- Carbon monoxide is colorless and odorless, but can be present with all other exhaust fumes. Therefore, if you ever smell exhaust fumes of any kind inside your vehicle, have it inspected immediately by your dealer and have the condition corrected. Do not drive with exhaust fumes present. If it is necessary to drive under such conditions, do so only with all windows fully open.
- Do not operate the engine in confined or closed areas (such as garages) any more than is needed to move vehicle in or out of the area.
- When the vehicle is stopped in an unconfined area with the engine running for more than a short length of time, adjust the heating or cooling system to draw outside air into the vehicle.
- Never sit in a parked or stopped vehicle for any extended amount of time with the engine running.

OPERATING CAUTION

Your Mazda Emission Control System can produce considerable heat. To avoid problems, please be sure to observe the following precaution:

Do

Do not operate or park the vehicle in areas where flammable materials such as dry grass may come into contact with heat from the exhaust system.

Under certain weather conditions, these materials could be ignited by a hot exhaust system.

Failure to observe the above precautions could result in extensive damage to your vehicle.

OPERATING PRECAUTIONS FOR CATALYTIC CONVERTER (For European models)

Your vehicle is equipped with a catalytic converter for exhaust emission purposes.

The following precautions must be observed:

1. UNLEADED FUEL only must be used.
2. Do not park the vehicle over or near flammable objects such as dry grass. Under certain conditions, these materials could be ignited by a hot exhaust system.
3. Do not operate the vehicle when there are signs of engine malfunction, such as engine misfire or other noticeable loss of performance.
4. Do not misuse or abuse the engine. Examples of misuse are, coasting with ignition off, going down steep grades in gear with ignition off.
5. Do not operate engine at high idle speed for extended periods (five minutes or more).
6. Do not allow the fuel tank to become empty.
7. Do not modify or tamper with any part of the engine or emission control system. All inspections and adjustments must be made by a qualified technician.

Failure to observe the above precautions could result in damages to the catalytic converter and your vehicle.

Heat Hazard Warning Light

If the catalytic converter should begin to overheat, the heat hazard warning light will come on.

HEAT HAZARD WARNING LIGHT



What to do:

1. Reduce speed, park your vehicle in a safe spot where there are no flammable materials and turn the engine off. Wait five minutes or more.
2. Check the spark plug wire connections. If any of them are disconnected, reconnect them properly (see page 6-25).
3. If the spark plug wires are properly connected, have your Authorized Mazda Dealer locate and correct the trouble as soon as possible. Park your vehicle until the heat hazard warning light goes out and then drive your vehicle to a dealer at slow speeds.

This warning light also comes on when the ignition switch is turned ON(II) (to check bulb operation), and should go out after the engine has been started.

2. BEFORE DRIVING YOUR VEHICLE

67U2 0010E

BEFORE ENTERING VEHICLE

- Be sure that all windows, outside rearview mirror(s), and outside lights are clean.
- Check tire pressures.
- Be sure the area to the rear is clear if you intend to back up.
- Check under the vehicle for any sign of leaks.

67U2 0030E

BEFORE DRIVING OFF

- Adjust the inside and outside rearview mirrors.
- Position the seat so that all controls are easily reached.
- Fasten seat belts.
- Check operation of warning lights when the ignition switch is turned to the ON(II) position.
- Be sure that all lights work.
- Check all gauges.
- Release the parking brake and make sure the brake warning light goes out.
- For safe operation, be sure you are familiar with your vehicle and its equipment.

97C2 0040E

BREAK-IN PERIOD

By following a few simple precautions for the first 1,000 kilometers, you may add to the performance, economy and life of your vehicle.

- Do not race the engine.
- Drive at various speeds without straining the engine.
- Avoid hard stops, except in emergencies. This will allow the brakes to seat properly.
- Avoid full-throttle starts.

97E2 0020E

Necessary inspections

Fluid levels, such as engine oil, engine coolant, brake and clutch fluid and windshield washer fluid, should be checked daily, weekly, or whenever you refuel, depending on the fluid. Further details are provided in Routine Services under Maintenance.

67U2 0050E

Inspection responsibilities

The owner is responsible for inspecting all driving, braking and backup lights, signaling systems and warning indicator lights frequently. Any malfunction should be corrected promptly.

SOUND WARNING SYSTEM

The warning sounds produced by Mazda's original units warn you of abnormal conditions that may have occurred in your vehicle. Do not forget about them. If you hear these sounds, prompt action should be taken to correct the condition. The warning function of this system is as follows;

1. Lights reminder
(See page 3-8)
2. Engine over-revolution (RED LINE) warning
(See page 3-20)
3. *Seat belt warning
(See page 2-11)
4. Coolant level warning
(See page 3-23)
5. Engine oil level warning
(See page 3-23)
6. *Convertible top warning
(See page 3-38)

* if equipped

Location of sound warning units

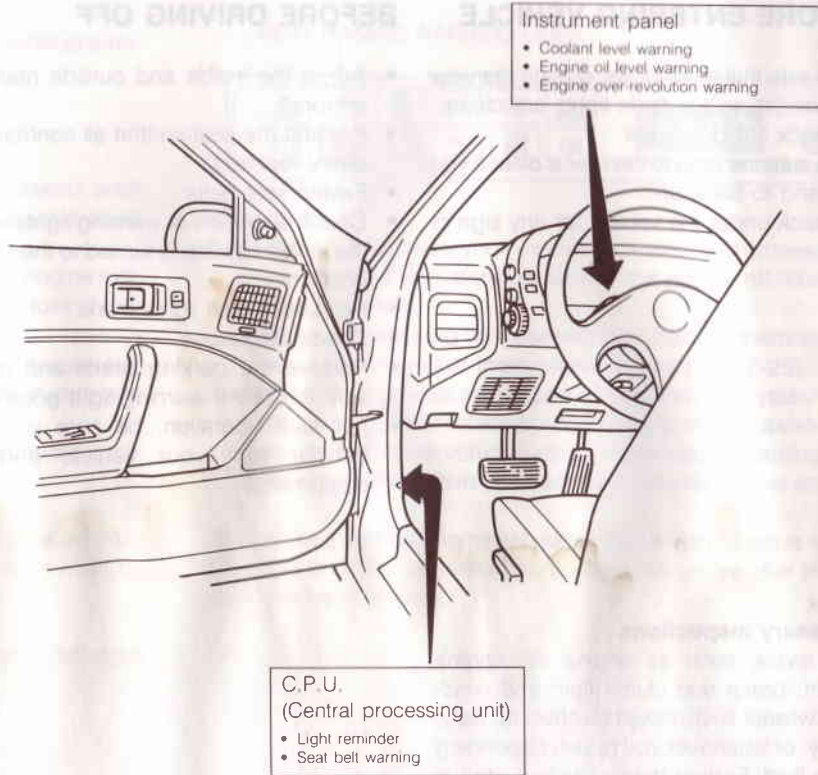

KEY

The key code number should be recorded and kept in a safe place for use in obtaining replacement keys if necessary.

DOOR LOCKS**From outside**

- Either door can be locked or unlocked with the key.
- Once the door is unlocked, it may be opened by simply pulling the door handle upward.

- To lock without the key, depress the inside lock button, then hold the door handle up and close the door.

CAUTION

Always remove the ignition key and lock all doors when leaving your vehicle unattended.

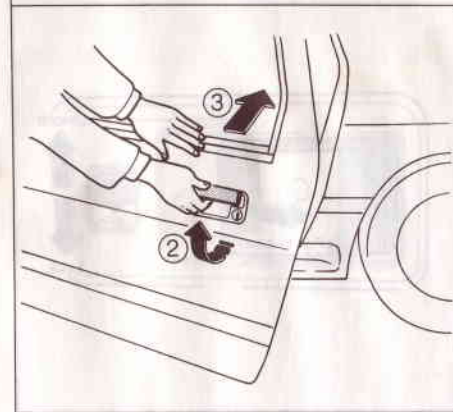
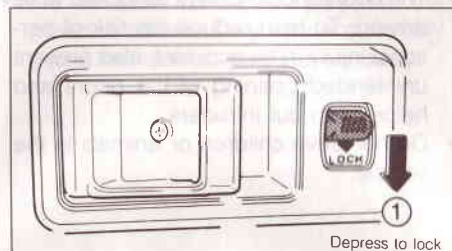
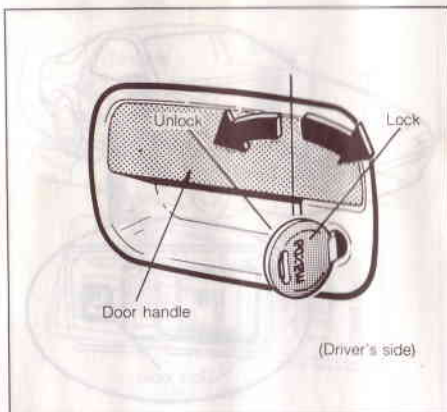
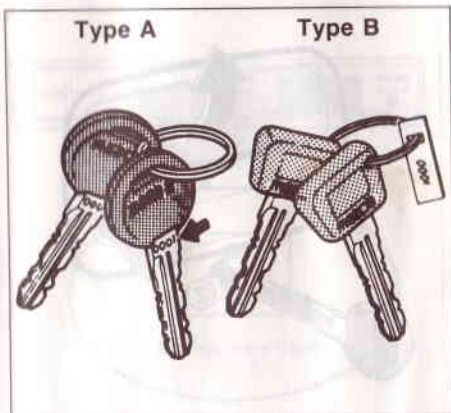

From inside

- To lock either door, depress the lock button.
- To unlock, pull the lock button up.
- To open, pull the door handle rearward.

WARNING!

- The doors should always be locked while driving. To help reduce the risk of personal injury in an accident, also prevent unintended opening of the doors and helps keep out intruders.
- Do not leave children or animals in the vehicle.

06U2 0095E

POWER DOOR LOCKS

All doors can be automatically locked or unlocked by depressing or lifting the driver's door lock knob.

67U2 0100E

DOOR LOCK CYLINDER ILLUMINATION (driver's door only)

To assist key insertion at night, a light inside the door panel illuminates the lock cylinder for approximately 15 seconds after the driver's door outer handle has been lifted.

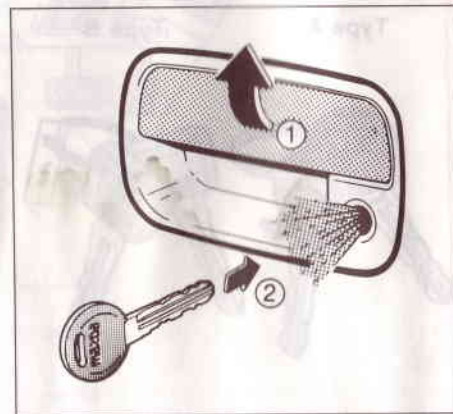
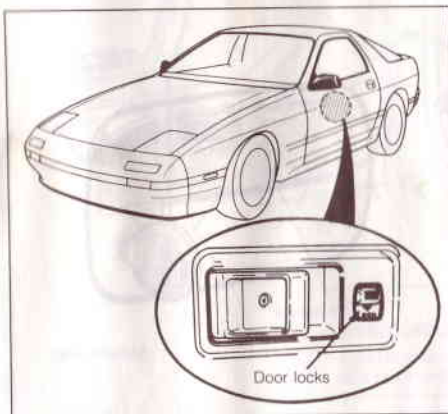
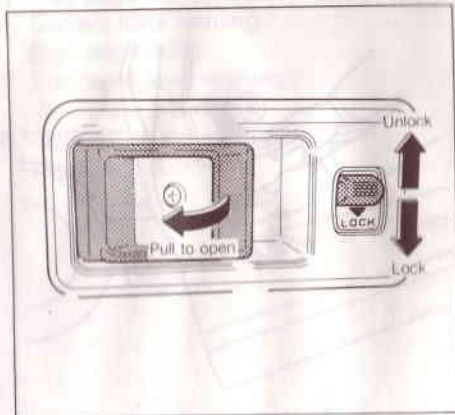

DOOR AJAR WARNING LIGHT

This warning light comes on when a door is not closed securely while the engine is running.

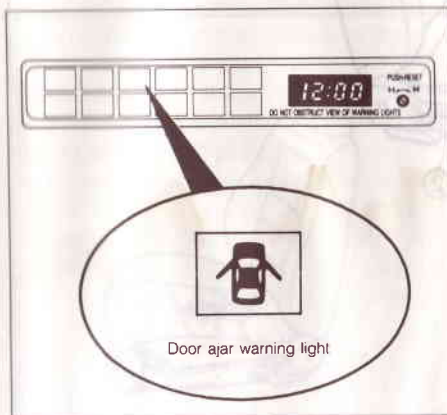
**POWER WINDOWS**

The ignition switch must be in the ON(II) position to operate the windows.

To open the window press the switch. To close the window raise the switch. With the window lock switch set in the OFF position, the windows can be operated only by the driver's switches.

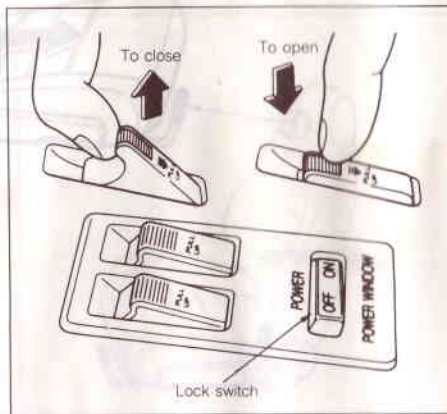
**WARNING!**

- Keep the window lock switch in the OFF position except when a power window is being operated.
- Use caution when closing the windows. Make sure all arms, hands, etc. are safely out of the way.
- Do not allow children to play with the power windows. They may accidentally injure themselves, perhaps seriously.

FRONT SEATS

1. **Seat slide adjustment lever**
2. **Seat reclining adjustment lever**

WARNING!

- **Do not adjust the driver's seat while the vehicle is moving, as this could cause loss of control, accident, and personal injury.**
- **Rear seat passengers should not lean on the front seatback while the vehicle is in motion. A seatback which is folded forward even a small degree may not lock properly in the event of a sudden stop or collision. Do not allow packages or other objects to interfere with the normal positions of the seatback. This may prevent the seatback from locking in the event of a sudden stop or collision (4-seater models).**



SEAT SLIDE ADJUSTMENT

To move the front seat forward or backward, pull the lock lever sideways and hold it. Slide the seat to the desired position, and release the lever.

CAUTION

Do not place anything under the front seats, as it might interfere with the seatlock mechanism.

**SEAT RECLINING ADJUSTMENT**

To change the seatback angle, lean forward slightly and pull up on the seatlock lever. Then lean back to the desired angle and release the lever. After adjustment, make sure the lever is returned to its original position; otherwise the seatback could unlatch while the vehicle is in motion and cause the driver to lose control.

**WARNING!**

To reduce the risk of sliding under the lap belt and thereby suffering personal injury in the event of a collision, do not recline the seatback any more than necessary for comfort. The seat belts are designed to provide optimum protection when the front passenger and driver are sitting well back and straight up in their seats. During a collision, particularly a frontal collision, the risk of personal injury may increase with the increasing recline of the seatback, as the front passenger and driver may slide under the lap belt and have restraint forces applied directly to their abdominal areas. Therefore, try to keep the seatback in a fairly upright position whenever possible.

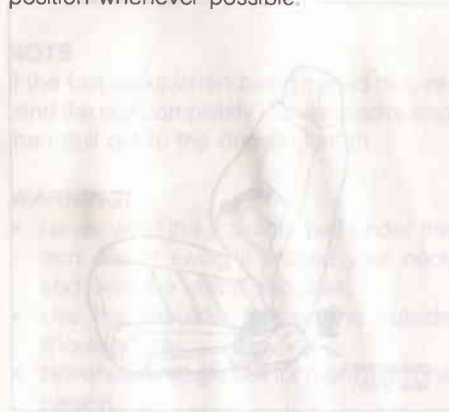

REAR SEAT ACCESS (Except cabriolet models)

Pull the seatback lever or depress the foot pedal (passenger's seat only). The seatback will fold down.

WARNING!

- Do not unlock the driver's seatback while the vehicle is in motion to prevent the risk of the driver losing control of the vehicle.
- Passengers sitting in the rear seat must be careful not to accidentally press the pedal while the vehicle is moving.



FOLDING REAR SEAT (Except cabriolet models)

The rear seatbacks easily fold forward and down to provide additional cargo space through the luggage compartment floor.

- To lower the seatback, pull the seatback latch forward to unlock it and then fold the seatback forward and down.
- To raise, lift the seatback and push it firmly into place.

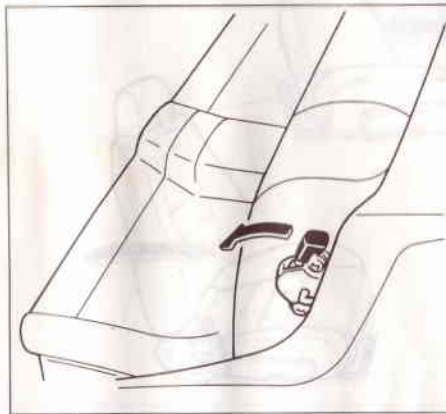

CAUTION

When replacing the seatback to the upright position, make sure it is securely latched by pushing forward and rearward.

WARNING!

- If the seatback is not securely latched, passengers or objects could be thrown forward and injury could occur in the event of a sudden stop or collision.
- To avoid possibility of burn injuries, do not remove the floor carpet in the cargo area. Emission controls cause high exhaust temperatures under the floor.
- Luggage or other cargo should not be piled higher than the seatbacks, as they may become dangerous projectiles in the event of a sudden stop or collision.
- To help prevent serious injuries in the event of sudden acceleration, quick stops or collisions, passengers should not ride in the cargo area, nor sit or recline on the folded seatbacks while the vehicle is in motion.
- Do not let children around the folded seatbacks to avoid their being trapped inside the cargo area by accident.

TILT STEERING WHEEL (if equipped)

To change the steering wheel angle, pull down on the lock-release lever located under the steering column. Tilt the steering wheel to the desired angle while holding the lever fully down and push up on the lock-release lever. After adjusting, move the steering wheel up and down to assure it is locked in position.

WARNING!

Never adjust the tilt position of the steering wheel while the vehicle is moving.



SEAT BELT RESTRAINT SYSTEM

Seat belts with retractors

To help decrease the possibility or severity of injury in accidents or sudden stops, we recommend that you and your passengers in the vehicle be properly restrained at all times, using the seat belts provided. The seat belts have retractors with inertia locks.

The retractors keep the belts out of the way while passengers enter or exit the vehicle. Inertia locks allow the belts to remain slack on the passengers for comfort until a deceleration force occurs (such as a sudden stop or collision). At that time the belts will automatically lock in position, and you and your passengers will be restrained.

WARNING!

- The seat belt assemblies may be damaged when subjected to stress by occupants in a collision and must be replaced.
- Passengers should not be allowed to ride in the cargo area of any vehicle. Persons who are not riding in a seat with a fastened seat belt are much more likely to suffer serious bodily injury in the event of a collision.

FRONT SEAT BELTS

To Fasten Seat Belt:

1. Grasp the buckle end and tongue plate.
 2. Slowly pull out the lap/shoulder belt.
 3. Insert the tongue plate into the open end of the buckle. An audible click will indicate the belt is securely locked.
- Position the lap belt across your lap as LOW ON THE HIPS as possible to reduce the risk of sliding under it during an accident. Adjust it to a SNUG FIT by pulling the belt through the tongue plate.
 - The belt retractor is designed to take up excess webbing automatically and maintain tension on the belt.

NOTE

If the belt locks when being pulled out, rewind the belt completely in the retractor and then pull out to the desired length.

WARNING!

- Never wear the shoulder belt under the arm. Never swing it around your neck and over the inside shoulder.
- Use the shoulder belt on the outside shoulder only.
- Never use a single belt for more than one person.

- Be sure the lap portion of the belt is fitted snugly around the hips, not on the waist.
- Failure to follow these precautions could increase the chance and/or severity of injury in an accident.

To Unfasten Seat Belt

To unfasten the belt, depress the release button.

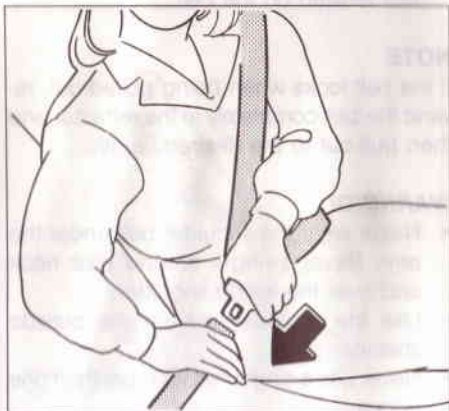

5FG2 0245E

REAR SEAT BELTS (If equipped) (For European models)

Use in the same manner as Front Seat Belts.

(Except European models)

To Fasten Seat Belt

Position the lap belt across your lap as LOW ON THE HIPS as possible.

If necessary, lengthen or shorten the lap belt. To adjust, hold the tongue at a right angle to the webbing and pull to lengthen, or pull the end of the belt webbing to shorten.

To Unfasten Seat Belt

To unfasten the belt, depress the buckle release button.

(Except European models)

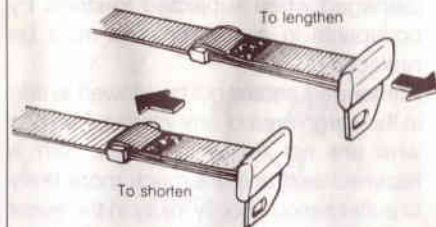

97U2 0250E

PROPER USE AND CARE OF SEAT BELT SYSTEM

To gain maximum effectiveness from the seat belt system, follow these suggestions:

- Use the belts at all times—even on short trips.
- Never use the same belt for more than one person at a time.
- Avoid wearing twisted belts.
- Keep sharp edges and damaging objects away from the belts and other parts of the restraint system.
- Periodically inspect belt webbing, buckles, anchors, and all other parts for signs of wear, damage, or weakness. Replace questionable parts immediately.
- To clean the belt webbing use any mild soap solution recommended for cleaning upholstery or carpets; follow the instructions provided with the soap. Do not bleach or redye the webbing as this may weaken it.
- No modifications or additions should be made by the user.
- After wearing a seat belt, make sure it is not caught on adjusting levers or elsewhere.

WARNING!

All seat belt assemblies including retractors and attaching harness should be inspected after any collision. Mazda recommends that all seat belt assemblies in use during a collision be replaced unless the collision was minor and the seat belts show no damage and continue to operate properly. Seat belt assemblies not in use during a collision should also be inspected and replaced if either damage or improper operation is noted.

SEAT BELT WARNING BUZZER SYSTEM (driver only, except European models)

If the driver's seat belt is not fastened when the ignition switch is turned to ON(II) position, the reminder buzzer will sound for about six seconds.

Anytime during the six seconds, the reminder buzzer will stop sounding immediately when you fasten the seat belt.

If the system does not operate as described, consult your nearest Authorized Mazda Dealer.

87U2 0270E

REAR GLASS HATCH/TRUNKLID

To open, insert the key into the key slot and turn it clockwise.

To close, use both hands to push the rear glass hatch/trunklid down until the lock snaps shut. Do not slam it.

Then pull up on the rear glass hatch/trunklid to make sure it is secure.

NOTE

When opening the rear glass hatch/trunklid in a low-ceilinged garage, be sure to open it with the key and to guard it with your hand.

WARNING!

To avoid drawing dangerous exhaust gases into the vehicle, do not drive with the rear glass hatch/trunklid open.

Cabriolet models

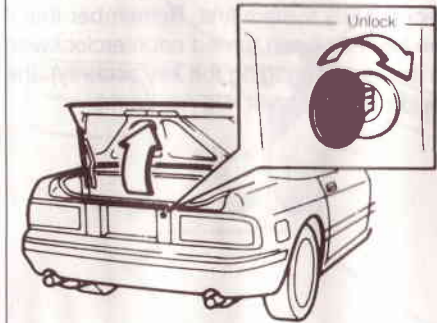

Except cabriolet models

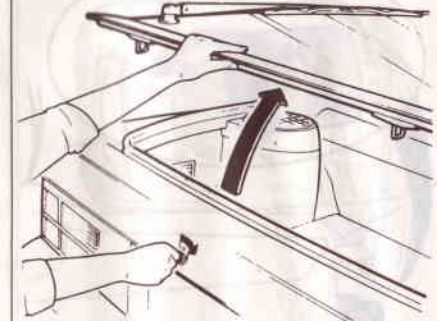

67U2 0290E

REMOTE REAR GLASS HATCH/ TRUNKLID RELEASE

To release the rear glass hatch/trunklid, pull up the release lever located next to the driver's seat.

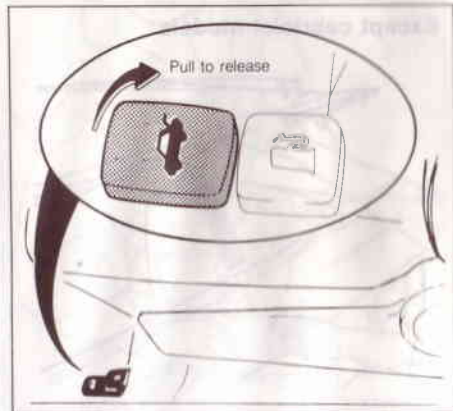

97E2 0285E

TRUNK KEY SECURITY SYSTEM (Cabriolet models)

As an extra measure of security, the inside trunk release lever function may be cancelled to prevent anyone inside the vehicle from opening the trunk. To disable the inside release lever, close the trunk and simply insert the primary key in the trunk lock, then turn the key counterclockwise (you will hear a click).

To enable the inside release lever to operate (in other words, to cancel the security function), simply turn the primary key clockwise (you will hear a click).

CAUTION

In case the inside release lever does not open the trunk, always be sure to check the security key system first. Remember that if the key has been turned counterclockwise in the lock (engaging the key security), the inside release lever will not work!



67U2 0290E

REAR GLASS HATCH AJAR WARNING LIGHT (if equipped)

This warning light comes on when the rear glass hatch is not closed securely while the engine is running and the parking brake is released.



REFUELING

FUEL FILLER LID

To open the fuel filler lid, pull up the remote fuel filler lid release knob, located next to the driver's seat.

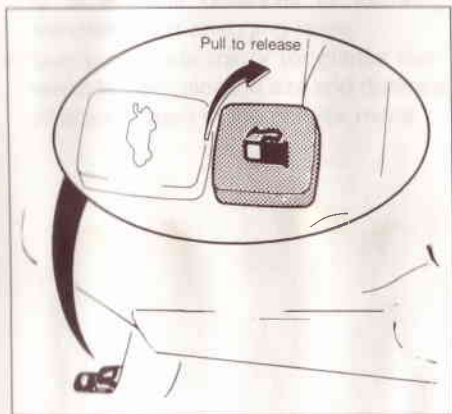

If for any reason the remote fuel filler lid release does not operate normally, open the rear glass hatch/trunklid and peel back the carpet trim on the right side of the compartment. Clear away any additional insulation. Now reach into the opening and pull the filler lid release toward the rear of the vehicle.

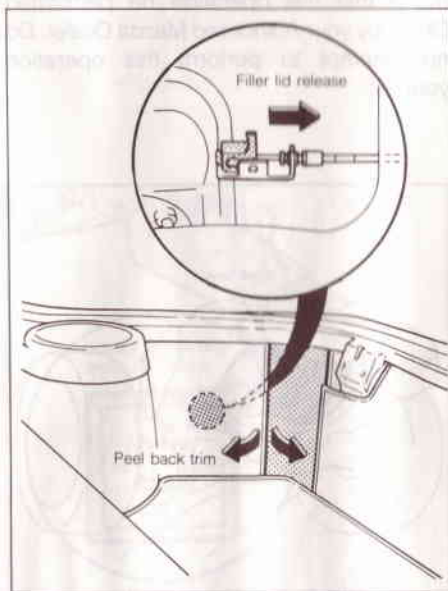

FUEL TANK FILLER CAP

To remove the cap, turn the cap counter-clockwise, and remove.

To install the cap, turn it clockwise until you hear a click. This signals that the cap is securely tightened.

NOTE

If the fuel filler lid will not open in cold weather because the area around it is frozen, push or lightly tap on the lid to open it.

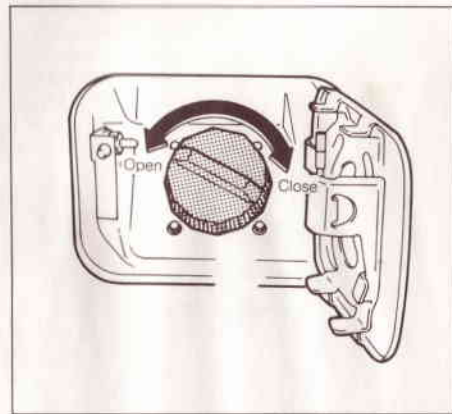

WARNING!

- If the fuel tank cap requires replacement, use only a genuine Mazda filler cap or equivalent specified for your model.
- When refueling, always stop the engine and never allow sparks or open flames near the filler neck. Fuel vapor is extremely hazardous under certain conditions.

77U2 0315E

FUEL TANK DRAIN PLUG

Fuel may include some accumulated water, sediment, or foreign materials, and cause problems in driveability and damage to the fuel system. Draining and cleaning of the fuel tank is strongly recommended once a year to maintain peak performance from your vehicle.

However, draining and cleaning a fuel tank can be extremely dangerous and we recommend that this operation be performed **ONLY** by your Authorized Mazda Dealer. Do not attempt to perform this operation yourself!.

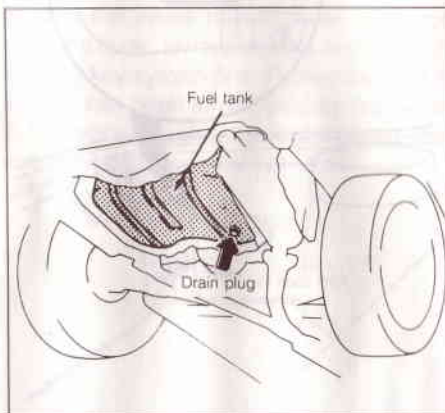

POWER OUTSIDE REARVIEW MIRROR

CAUTION

Do not scrape ice off the mirror face, or it may damage the surface of the glass. If ice should restrict movement of the mirror, do not force the mirror to adjust it. To remove any ice, use a de-icer (spray type, blower type etc.), sponge or soft cloth.

WARNING!

- Outside rearview mirrors are convex as noted on the face of the mirror. Objects seen in the mirror are closer than they appear. The mirror should be used carefully to estimate distances of following vehicles when changing lanes.
- Use your inside mirror (or glance rearward) to determine the size and distance of objects seen in the convex mirror.

The power outside rearview mirror switch is located on the center console panel. This switch controls the adjustments for both right and left outside rearview mirrors. To adjust the position of either mirror:

1. Move the selector switch to the right or left to activate the adjusting mechanism for the corresponding door mirror.
2. Adjust the mirror angle by depressing the appropriate perimeter switch as illustrated.

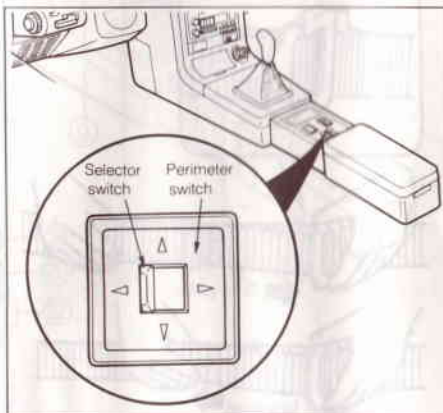

CAUTION

The mirrors stop moving when they have reached the maximum adjusting angles, but the motor continues rotating while the switch is on. Do not leave the switch on for unnecessary lengths of time.

97U2-0350E

DAY-NIGHT REARVIEW MIRROR (If equipped)

Push the lever forward for daytime driving.
Pull the lever back for night driving.

NOTE

Remember that you lose some rearview clarity by reducing glare in the night position.

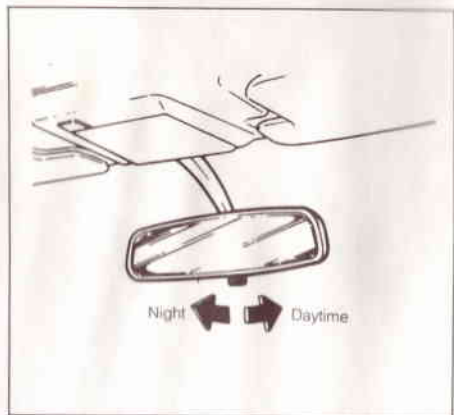

97U2-0360E

LUGGAGE STRAPS (Except cabriolet models, if equipped)

There are straps in the luggage space to secure luggage while travelling.

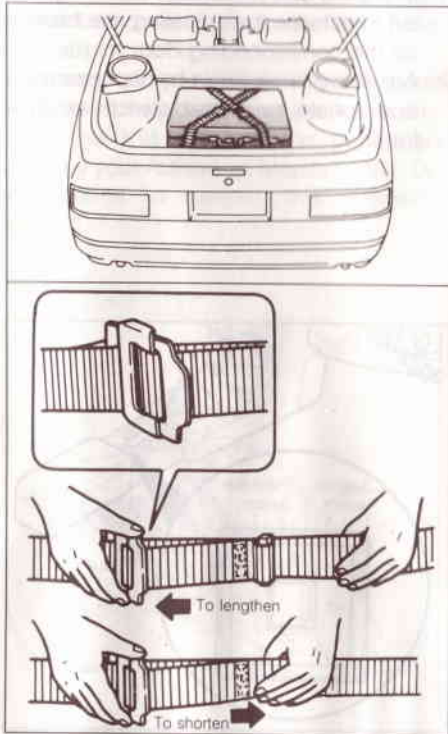

POWER OUTSIDE REARVIEW MIRROR

CAUTION
Do not scrape or hit the mirror glass or the glass may crack. Do not touch the surface of the glass. Do not touch the mirror housing of the mirror. Do not touch the mirror glass. To remove any ice use a soft, clean, dry cloth. Do not use a sharp object to clean the mirror.

WARNING
• Outside rearview mirrors are convex. Objects in the rear view of the mirror appear smaller and further away than they actually are. The distance between you and the vehicle will change rapidly. Use your mirrors for general rearward observation. Do not rely on mirrors to detect objects in the rear view.

3. STARTING AND OPERATING

971 1 00 100

INSTRUMENTS AND CONTROLS

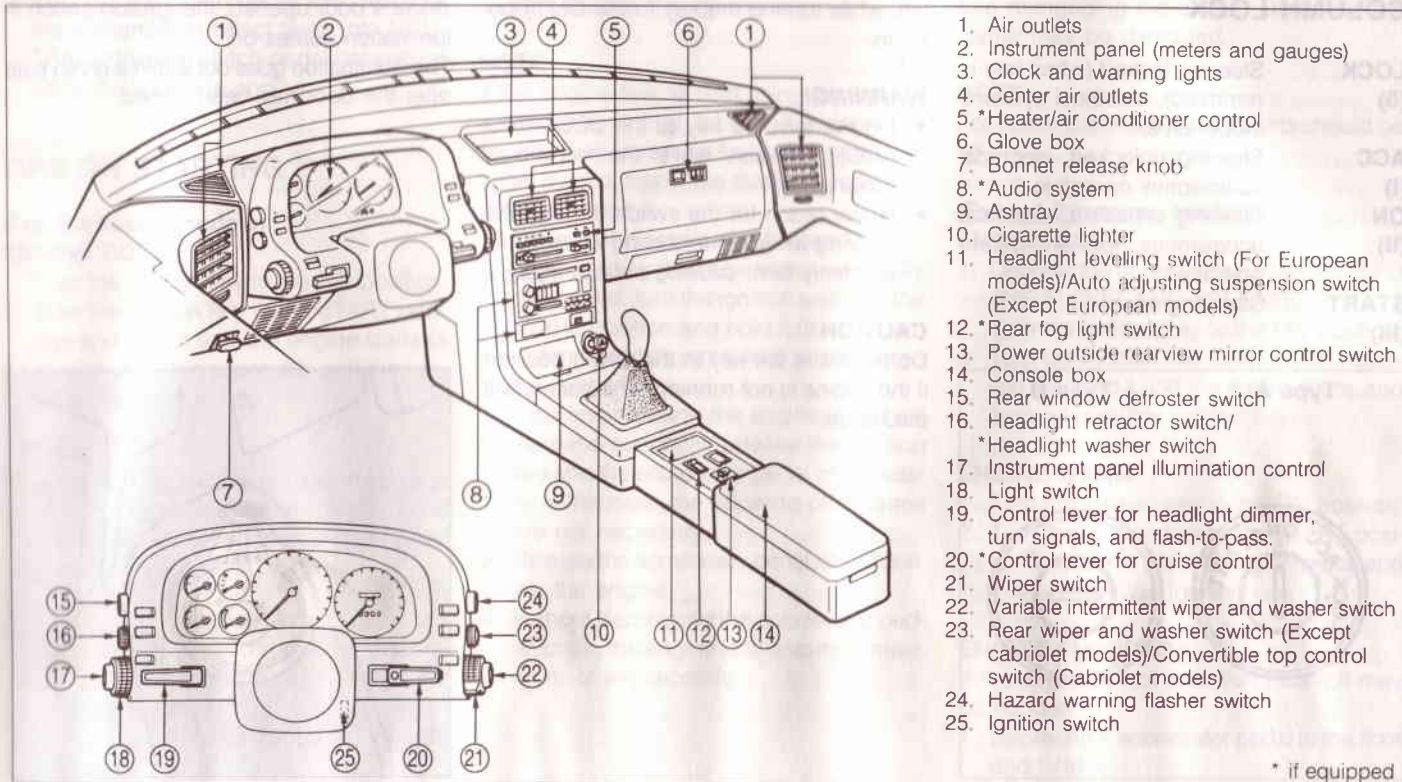

1. Air outlets
2. Instrument panel (meters and gauges)
3. Clock and warning lights
4. Center air outlets
5. *Heater/air conditioner control
6. Glove box
7. Bonnet release knob
8. *Audio system
9. Ashtray
10. Cigarette lighter
11. Headlight levelling switch (For European models)/Auto adjusting suspension switch (Except European models)
12. *Rear fog light switch
13. Power outside rearview mirror control switch
14. Console box
15. Rear window defroster switch
16. Headlight retractor switch/
*Headlight washer switch
17. Instrument panel illumination control
18. Light switch
19. Control lever for headlight dimmer, turn signals, and flash-to-pass.
20. *Control lever for cruise control
21. Wiper switch
22. Variable intermittent wiper and washer switch
23. Rear wiper and washer switch (Except cabriolet models)/Convertible top control switch (Cabriolet models)
24. Hazard warning flasher switch
25. Ignition switch

* if equipped

STEERING COLUMN AND SHIFT CONTROLS

97UJ-0030E

IGNITION SWITCH AND ANTI-THEFT STEERING COLUMN LOCK

LOCK (0) Steering locked (when key is removed), electrical systems inoperative.

ACC (I) Steering unlocked, electrical accessories operative.

ON (II) Steering unlocked, electrical accessories, ignition system operative.

START (III) . . . Start engine.

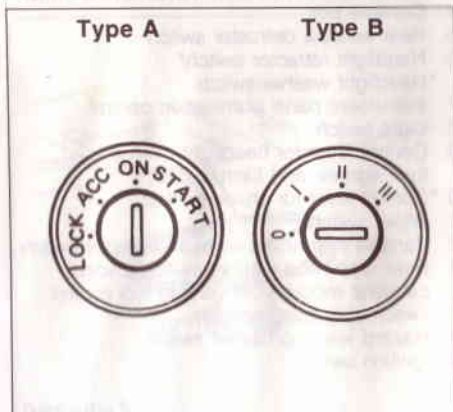

If difficulty is experienced in turning the ignition key, turn the steering wheel right and left, while turning the key to the ON(II) position.

WARNING!

- Do not turn the key to the LOCK(0) or ACC(I) position while the vehicle is moving.
- Never reach for the switch through the steering wheel. The steering wheel could suddenly turn, causing serious injury.

CAUTION

Do not leave the key in the ON(II) position if the engine is not running. The battery will discharge.

67UJ-0040E

IGNITION SWITCH ILLUMINATION

To assist key insertion at night, with the driver's door opened, the ignition switch illumination comes on.

The illumination goes out within a given time after the door has been closed.

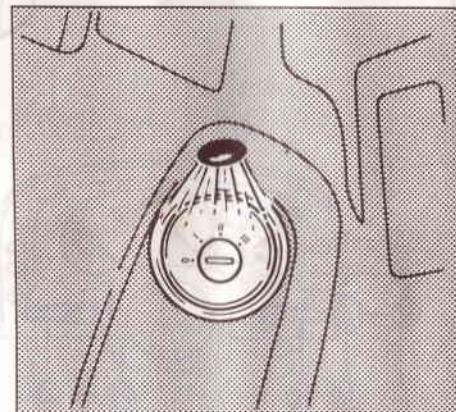

BEFORE STARTING ENGINE

1. Fasten the seat belt
2. Make sure the parking brake is applied.
3. Depress the clutch pedal fully and shift the transmission select lever into NEUTRAL. Hold the clutch pedal depressed while cranking the engine.

TIPS ON STARTING

(For European models)

ENGINE COLD

1. Turn the ignition key to the ON position.
2. Turn the ignition key to the START position and hold it until the engine starts (a maximum of ten seconds), and then release the ignition key.

NOTE

To aid in warming-up the engine, the engine speed is automatically set to 2,500 ~ 3,000 rpm for about 20 seconds after starting the engine.

3. After about 15 seconds from engine starting, the engine speed should be reduced by slightly depressing the accelerator pedal and releasing it.
4. Be sure that the engine speed is reduced. You are ready to drive.

ENGINE WARM

1. Turn the ignition key to the ON position.
2. Turn the ignition key to the START position and hold it until the engine starts, and then release the ignition key.

NOTE

If the engine fails to start using the normal procedures, it may be that the engine is flooded (has excessive fuel in the cylinders). If this is case, follow the starting procedure outlined below.

1. Depress the accelerator fully and hold it.
2. While holding the accelerator pedal fully depressed, turn the ignition switch to the START position and hold it (a maximum of ten seconds; cranking) to discharge the excess fuel.

If the engine starts, the engine speed will increase suddenly; release the ignition key and the accelerator pedal immediately. In this case, the following procedures are not necessary.

3. Release the accelerator pedal after cranking the engine.
4. Without depressing the accelerator pedal, crank the engine until it starts (a maximum of ten seconds).

CAUTION

Do not keep the starter engaged for more than ten seconds. If the engine stalls or falters in starting, wait five to ten seconds before reengaging the starter. Otherwise the starter may be damaged.

NOTE

For easier starting, the headlights should be off.

(Except European models)

ENGINE COLD

1. Depress the accelerator pedal ONCE TO THE FLOOR AND RELEASE.
2. Turn the ignition key to the ON position.
3. Turn the ignition key to the START position and hold it until the engine starts, and then release the ignition key.

ENGINE WARM

1. Turn the ignition key to the ON position.
2. Turn the ignition key to the START position and hold it until the engine starts, and then release the ignition key.

ENGINE FLOODED

If the engine is hot and won't start, it may be flooded.

1. Depress the accelerator pedal to the floor and hold it.

2. Turn the ignition key to the START position and hold it.
3. When the engine starts, and runs smoothly release the ignition key and accelerator pedal.

CAUTION

Do not keep the starter engaged for more than ten seconds. If the engine stalls or falters in starting, wait five to ten seconds before reengaging the starter. Otherwise it may be damaged.

NOTE

For easier starting, the headlights should be off.

97E3-0065E

A WORD ABOUT THE TURBOCHARGER (if equipped)

Mazda's RX-7 turbocharger greatly enhances engine power and is an advanced unit in both design and operation. To get maximum performance from your turbocharger, take note of the following tips:

1. Make sure to change engine oil and filter referring to Section 6 of this manual for the details.
2. Use only engine oil with API Service SD, SE or SF rating. The use of extra addi-

tives is NOT recommended.

3. After a drive at freeway speeds or after ascending a long hill, take 30 seconds or more to allow the engine to idle and cool the turbo before turning it off. Avoid simply cutting the engine off abruptly after a hard or long drive.
4. Watch the turbo boost meter in your gauge cluster and get to know how it operates. Remember that if the indicator shows more boost than the highest amount on the meter, stop the vehicle or slow down to a point where the boost drops back to normal. Continuing to drive under this overboost condition can damage engine components, so contact your Authorized Mazda dealer immediately to have the problem corrected. (See page 3-20 for boost meter information)
5. Do not race or over-rev your engine when starting. This should never be done on ANY engine, but especially not on a turbocharged engine.
6. Be sure to keep the hood scoop for the intercooler free of leaves and debris. Do not block off the scoop since it provides air for the turbo intercooler.

97E3-0070E

TRANSMISSION OPERATION

NOTE

A special safety feature prevents inadvertent shifting from 5th to R (Reverse). Shift lever must be returned to NEUTRAL position (as shown) before Reverse gear can be engaged.

CAUTION

To avoid premature clutch wear and damage, do not drive with your foot resting on the clutch pedal, or use the clutch to hold the vehicle at a standstill on an upgrade, as when waiting for a traffic light.

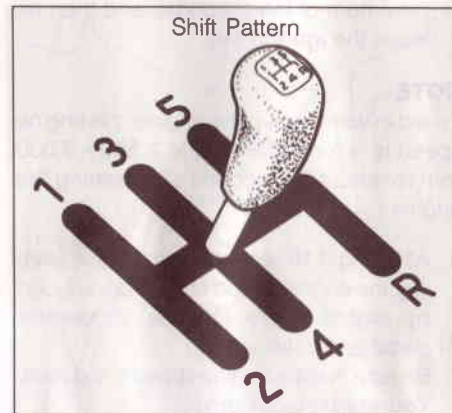

SHIFT POINT RECOMMENDATIONS (For European models)

In order to save fuel consumptions and improve driveability, it is recommended to shift up at speeds explained below.

FIRST GEAR Up to 24 km/h, then shift to second.

SECOND GEAR Up to 40 km/h, then shift to third.

THIRD GEAR Up to 64 km/h, then shift to fourth.

FOURTH GEAR Up to 72 km/h, then shift to fifth.

FIFTH GEAR From 72 km/h, up to cruising speed.

NOTE

Once the vehicle reaches the desired road speed (or when the vehicle speed is compatible with traffic flow or legal speed limits) at approximately 40 km/h or above, the transmission should be shifted into **FOURTH gear** as soon as possible to maintain best fuel economy.

Downshifting from **FOURTH gear** is not necessary unless the engine begins to lug (this condition is likely at speeds of 30 km/h or less).

SUGGESTIONS FOR ECONOMICAL OPERATION

Your vehicle's fuel economy is mainly dependent on your style of driving, how you drive, where you drive and when you drive. These have an effect on how many kilometers you can get from a liter (gallon) of fuel. To operate your vehicle as economically as possible, use the following driving suggestions to help save money in both fuel and repairs:

- Never turn off the engine to coast down hills. Your power steering and brake booster will not function without the engine running. Instead, downshift to an appropriate gear to utilize engine braking effect.
- You can save fuel by avoiding fast starts.
- Keep your engine in tune and follow the recommended periodic maintenance schedule. This will increase the life of all parts and lower operating costs.
- Use the air conditioner (if equipped) only when necessary.
- Slow down when driving on rough roads.
- Always keep your tires inflated to the recommended pressure for longer tire life and fuel economy.

- Keep your distance from other vehicles to avoid sudden stops. This will reduce wear on brake linings and save fuel, as extra fuel is required to accelerate back to driving speed.
- Do not carry unnecessary weight in the vehicle.
- Do not rest your foot on the brake pedal while driving. This causes needless wear and possible damage to the brakes and poor fuel economy.
- Improper wheel alignment will cause the tires to roll at an excessive angle, which will result in faster tire wear. It takes more power to overcome this improper alignment which, in turn, wastes fuel.
- Open windows at high speed can lessen fuel economy. Also, fuel economy is less when driving in crosswinds or headwinds. To help offset some of this loss, slow down when driving in these conditions.

Keeping a vehicle in good operating condition is important both for economy and safety. Therefore, have your Authorized Mazda Dealer perform scheduled inspections and maintenance.

CRUISE CONTROL

The cruise control system allows you to automatically control the speed of your vehicle above approximately 40 km/h (25 mph). To activate the system, push the MAIN switch located on the cruise control lever (see below).

To deactivate, push the switch again.

NOTE

The indicator light comes on when the MAIN switch is pushed in.

WARNING!

Never reach through the steering wheel to operate the MAIN switch.

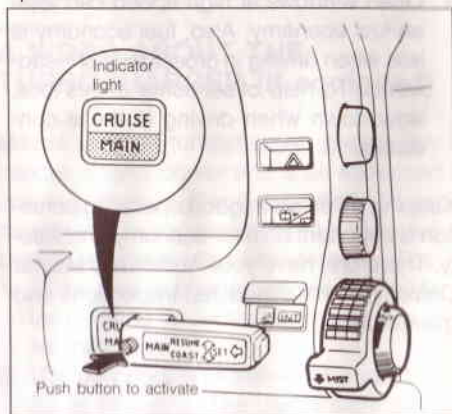

To set the desired constant vehicle speed:

1. Accelerate to the desired cruising speed (must be above 40 km/h, 25 mph).
2. Momentarily press the SET button located on the end of the control lever. Do not hold the SET button in.
3. Release the accelerator pedal and the vehicle speed will be automatically maintained.

NOTE

The indicator light comes on when the vehicle is in the cruise control mode and it turns off when the cruise control mode is cancelled.

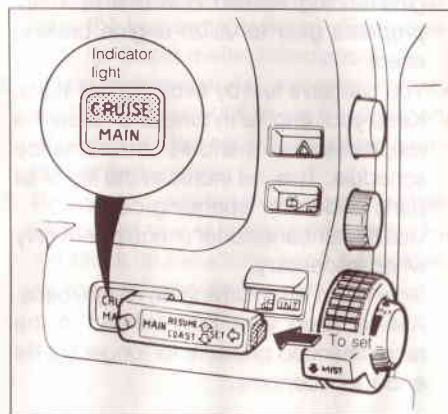

To increase cruising speed:

1. Push the SET button and hold it. Vehicle speed will increase at a controlled rate.
2. Release the button when the desired speed is reached.

To decrease cruising speed:

1. Move the control lever downward to the COAST position and hold it.
2. The vehicle will gradually slow down. When the desired speed is reached, release the lever. The new cruising speed will be maintained.

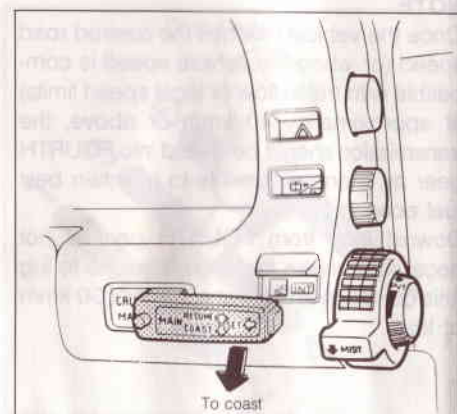

To cancel cruising speed:

- Push the MAIN switch to deactivate (turn off) the cruise control system, or;
- Slightly depress the brake pedal or clutch pedal, or;
- The cruise control system will automatically cancel if the vehicle slows down to approximately 15 km/h (9 mph) below the pre-set speed.

In addition, the system is turned off each time when the ignition switch is turned off.

To resume cruising speed at above 40 km/h (25 mph):

If the cruising speed has been cancelled by some method other than by using the MAIN switch (i.e., the system is still activated), the last preset cruising speed can be resumed by moving the control lever upward to the RESUME position and then releasing it. The vehicle speed will gradually increase and will automatically resume the last preset speed. Note, however, that the last preset cruising speed cannot be resumed if the vehicle speed drops to less than 40 km/h (25 mph).

NOTE

- When driving with the cruise control system in use, you may accelerate your vehicle for passing another vehicle as you normally would, by pressing the accelerator. When you release the pedal, the cruise control will return your vehicle to the pre-set speed.
- A slight speed change may occur when going up or down steep hills, even though the cruise control is engaged.

WARNING!

Do not use the cruise control system in conditions such as heavy or varying traffic, or on slippery or winding roads.

CAUTION

A flashing cruise indicator light indicates a possible malfunction in the cruise control system. Have the vehicle checked by an Authorized Mazda Dealer.

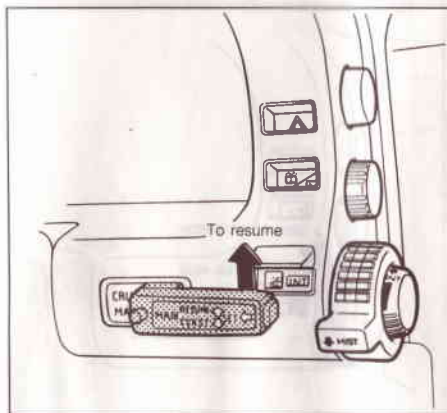

LIGHTING AND TURN SIGNALS

Models for Norway

Regulations require that lights be illuminated during the day.

These lights are called running lights, and for the RX-7 the headlights also serve as running lights. They are automatically switched ON when the ignition is switched ON.

1. LIGHTING CONTROL

To operate the lights, twist the large dial as indicated below:

First click stop (☐):

Parking, license, tail, side marker, and instrument panel lights come on.

Second click stop (≡):

Headlights rise; low beam headlights, parking, license, tail, side marker and instrument panel lights come on.

Headlight beam control

With the headlights on, the high or low beams are selected alternately, each time the lever is pulled toward the driver.

The high beam indicator illuminates in blue when the headlight high beams are switched on.

97U3-0150E

LIGHTS REMINDER

If you forget to turn off the lights when stopping the engine, the reminder beep will sound as soon as a door is opened.

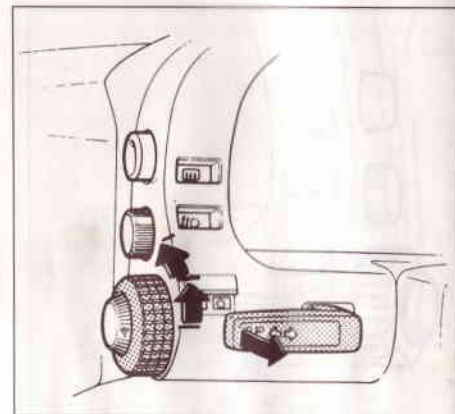
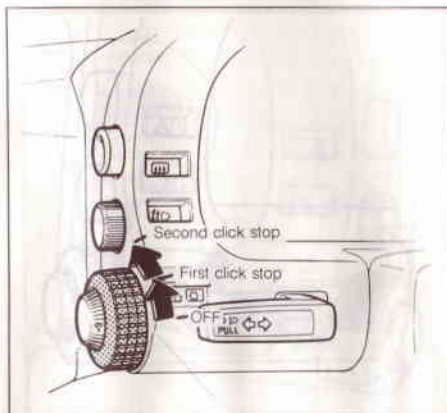

HEADLIGHT LEVELING SWITCH (For European models)

The projected angle of the headlights changes with the number of occupants and load weight in the vehicle luggage compartment. This switch is used to adjust the projected angle. Select the proper setting by referring to the chart.

(Except cabriolet models)

Front seat		Rear seat	Load	Switch position
Driver	Passenger			
X	—	—	—	0
X	X	—	—	0
X	X	X	—	2
X	X	X	X	2
X	—	—	X	3

(Cabriolet models)

Driver's seat	Passenger's seat	Load	Switch position
X	—	—	0
X	X	—	0
X	X	X	1
X	—	X	1

Flash-To-Pass System

This system enables you to quickly flash your headlights to signal your intent to either pass a slower vehicle or to get the attention of vehicles approaching from ahead.

Flash-to-pass simply by jiggling the turn signal toward you, using a fluttering motion with your left fingers.

The lights can be flashed with the headlights either open or closed.

- To flash the lights with the headlights open and the low beam headlights on, pull the control lever towards you twice. This will engage high beam momentarily and then return the lights to low beam.

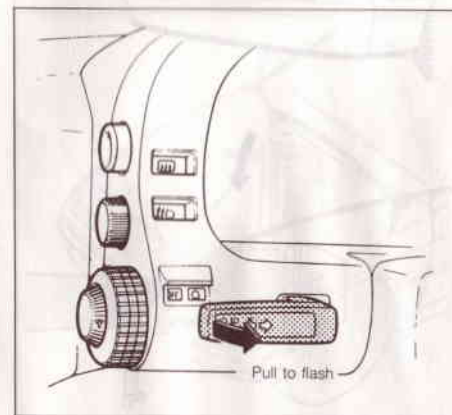
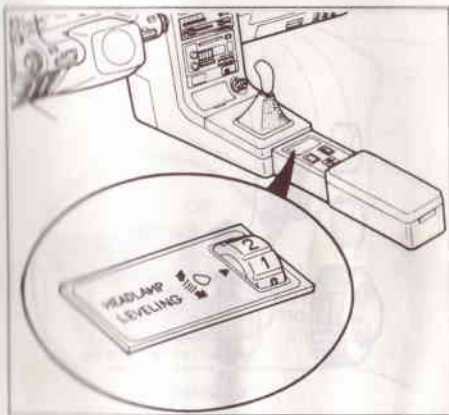

- To flash the lights with the headlights closed, pull the control lever fully toward you. The headlights will come on as shown below, until the lever is released.

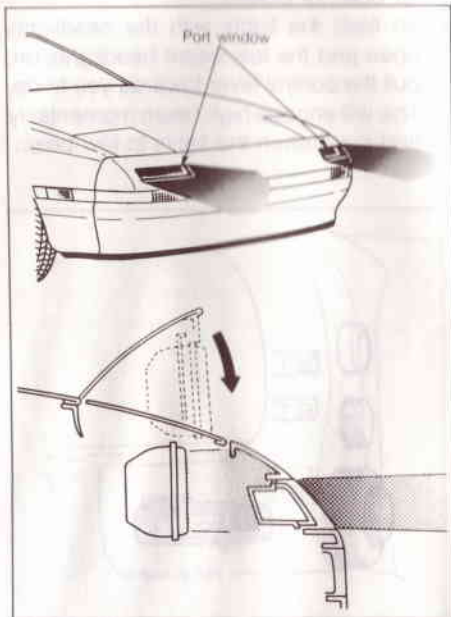

67U3 0140E

CLEANING THE PASSING PORT WINDOWS

To clean the inside face of the passing port windows, raise the headlights with the headlight retractor switch, then open the hood. Clean the port windows with a soft cloth and clear water.

WARNING!

To avoid personal injury that might occur due to accidental lowering of the headlights while you are cleaning the port windows, remove the proper 30A main fuse (see page 3-12). You may also disconnect the negative battery instead of removing the fuse. Remember that station settings memorized on the radio will be erased if the battery is disconnected.

67U3 0160E

2. TURN AND LANE-CHANGE SIGNAL

Turn Signals

Move the lever up or down to the stop position to engage the turn signals. The turn signals will self-cancel after the turn is completed.

Lane-Change Signals

Move the lever part way and hold it there. The lever will return to the OFF position when it is released.

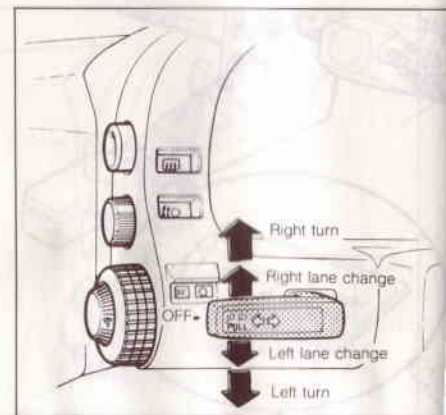

REAR FOG LIGHT (For European models)

When visibility is poor due to thick fog, turn on the rear fog lamp to prevent other vehicles from colliding into your vehicle from behind.

The indicator light comes on when the rear fog light switch is pushed in.

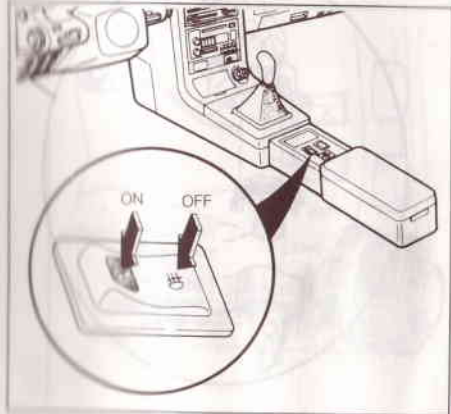

HEADLIGHT RETRACTOR

For convenience sake, an independent headlight retractor switch (the headlights do not turn on) is provided. The switch can be operated with the ignition switch on or off. Turn the switch to open the headlights when it is necessary for ...

- Washing the vehicle
- Preventing the headlights from freezing during the night
- Repairing a headlight

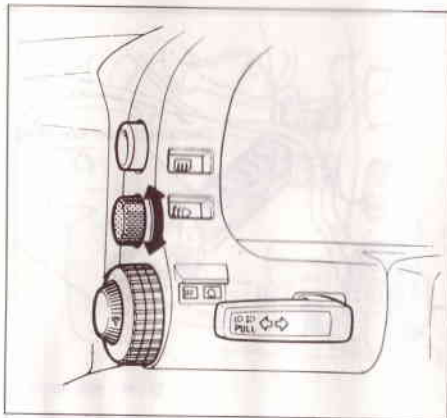

CAUTION

- It is possible, (during very cold weather or while driving on a snow-covered road,) that the headlight retractor mechanism and the area around the headlight cover might become frozen. If this trouble occurs, do not try to raise or lower the headlights because trying to force the headlights up or down in this way might cause damage to the headlight retractor mechanism. It might also cause the battery to become discharged, or some other problem. Therefore, before attempting to raise or lower the headlights, be sure to first open the hood and break or than the ice.

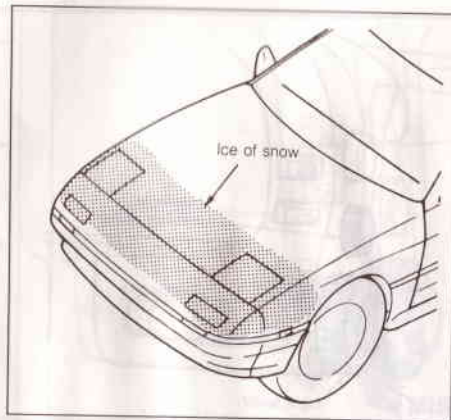

- We recommend that the headlights be kept in the raised position for parking and driving under very cold weather.

To raise the headlights, only use the headlight retractor switch, do not use the light switch.

- If a pebble, piece of ice, etc. gets lodged in a headlight and prevents it from opening or closing while the switch is being operated, perform the following steps:

1. Disconnect either the negative (-) battery terminal or the first (30A) main fuse.
2. Dislodge the obstruction.
3. Re-connect the battery terminal or main fuse.

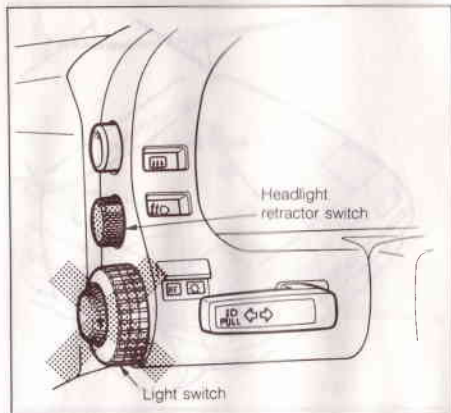

4. Check the headlight retractor operation. (Remember the radio station settings may be erased if the battery is disconnected.)

NOTE

In emergencies, the headlights may be set in the opened or closed position manually. First disconnect the (30A) main fuse marked RETRACTOR. This fuse is closest to the outside of the driver's side fender. Then, remove the cover for each light (see illustration) and turn the knob on the retractor motor shaft until the headlight is fully opened or closed as illustrated below right.

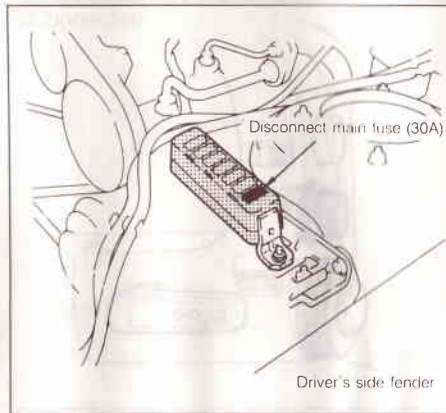

WARNING!

Do not turn the knob if the (30A) main fuse is connected. The retractor motor may suddenly move and cause an injury.

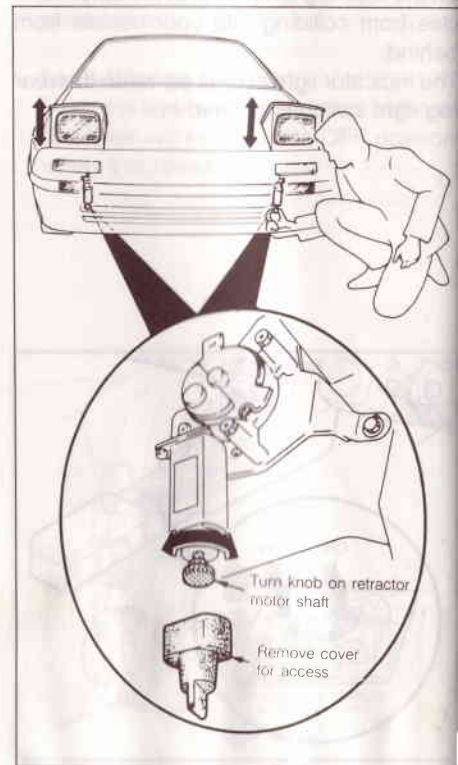

WINDSHIELD WIPER AND WASHER CONTROLS

1. WIPER

To turn the wipers on, turn the large dial, as illustrated.

INT — Intermittent wiper operation

I — Slow wiper speed

II — Fast wiper speed

CAUTION

- To prevent possible damage to the wipers or windshield, do not operate the wipers when the windshield is dry.

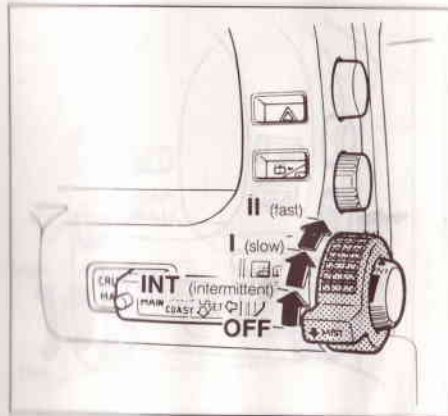

97U3 0190E

Variable-speed intermittent wiper

This feature operates the wipers at selected intervals. Such operation can be handy in conditions of light rain, etc.

Set the large dial to the INT position and choose the desired time delay interval for the wiper. Do this by turning the INT knob as illustrated.

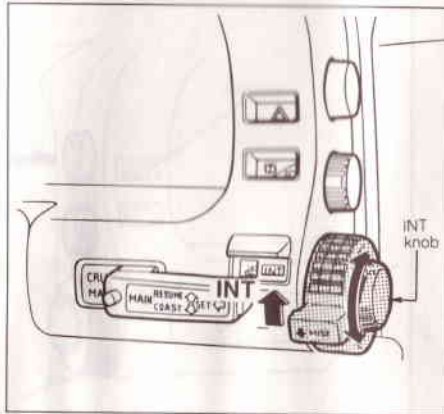

97U3 0200E

ONE-TOUCH MIST

For a single wipe cycle, push the wiper dial downward to the MIST position and release it.

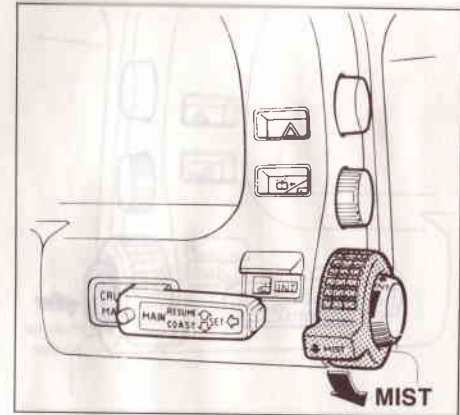

WASHER

To clean the windshield, push the washer button as illustrated, and hold it. Washer fluid is sprayed and the wipers are activated until the button is released.

If the washer does not work, check the washer fluid level, which may be low. If the fluid level is sufficient, consult your Authorized Mazda Dealer. (See page 6-14.)

WARNING!

Do not use the washers in freezing weather without first warming the windshield with the defrosters, otherwise the washer solution may freeze on the windshield and obscure your vision.

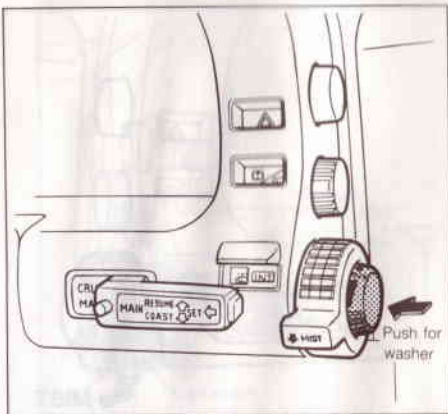
**CAUTION**

Do not operate the windshield washer when the washer fluid reservoir is empty to prevent possible damage to the washer pump system.

HEADLIGHT WASHER

The headlight washer can only be used with the headlights in the open position.

With the ignition switch in the ON(II) position, push the retractable headlights switch in, as illustrated below. Washer fluid will be sprayed onto the headlights until the switch is released.

CAUTION

Do not operate the headlight washer for more than ten seconds at a time.

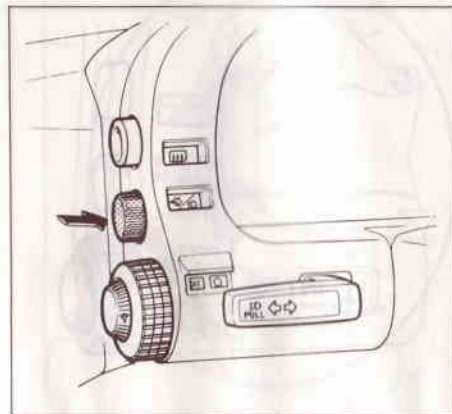

INSTRUMENT PANEL ILLUMINATION CONTROL

Rotate the small dial to adjust the instrument panel illumination light brightness as illustrated below.

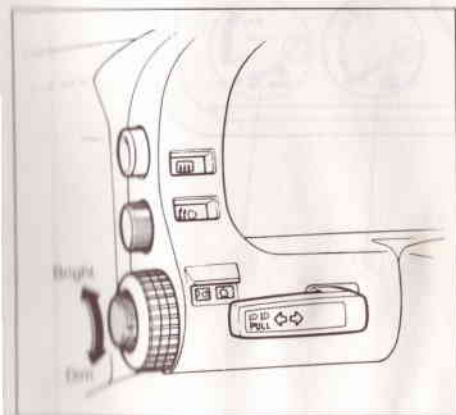

REAR DEFROSTER

This defroster clears frost, fog, or thin ice from the interior and exterior of the rear window.

Start the engine before operating the defroster and if there is a heavy accumulation of snow on the rear window, brush it off. Depress the switch to operate rear window defroster.

CAUTION

To prevent damage to the conductors, which are bonded to the inside surface of the rear window, never use sharp instruments or window cleaners containing abrasives to clean the inside of the rear window.

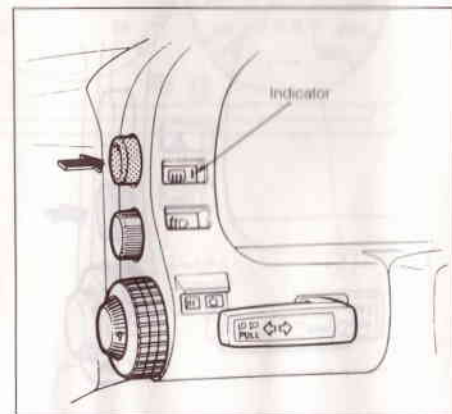

NOTE

The rear defroster is switched off automatically after 15 minutes. To reactivate the defroster, simply push the switch again.

The indicator light illuminates when the rear window defroster is operating.

97E3 0250E

REAR WINDOW WIPER (Except cabriolet models)

To activate the rear window wiper, set the switch in the INT or ON position.

- INT** — Intermittent wiper operation
- ON** — Normal operation

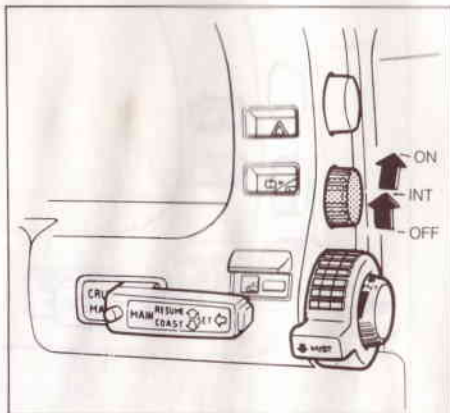

97U3 0260E

REAR WINDOW WASHER (if equipped)

To clean the rear window, push the switch and hold it. Washer fluid is sprayed and the wipers are activated until the switch is released.

If the washer does not work, check the washer fluid level which may be low. If the fluid level is sufficient, consult your Authorized Mazda Dealer. (See page 6-15.)

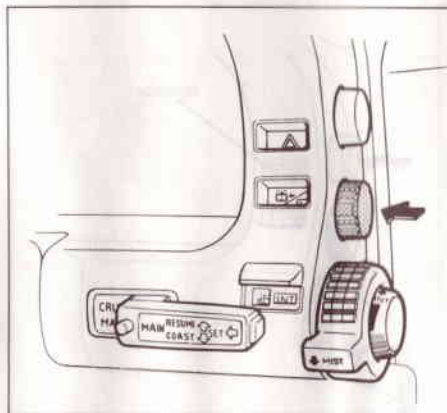

INSTRUMENT PANEL

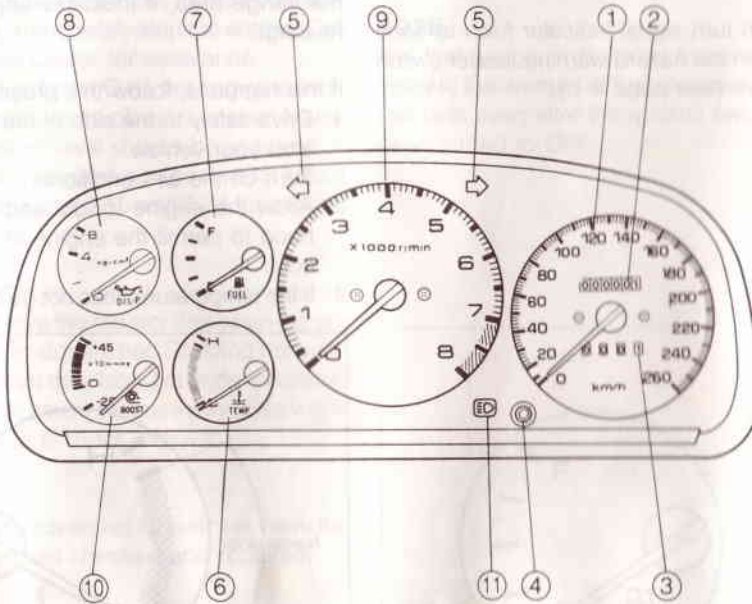

1. Speedometer
2. Odometer
3. Tripmeter
4. Tripmeter reset knob
5. Turn signal/hazard warning flasher indicator
6. Water temperature gauge
7. Fuel gauge
8. Engine oil pressure gauge
9. Tachometer
10. Voltmeter (Non-turbo models) or Boost meter (Turbo models)
11. High beam indicator

1. SPEEDOMETER

The speedometer indicates speed in kilometers (miles) per hour.

2. ODOMETER

The odometer records the total distance the vehicle has been driven.

3. TRIPMETER

The tripmeter may be set to zero to record the distance on each trip.

4. TRIPMETER RESET KNOB

Simply push the knob to reset to zero.

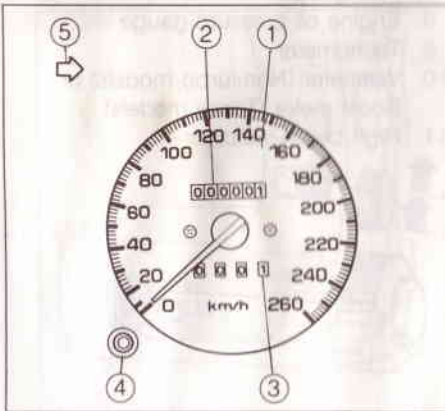
**5. TURN SIGNAL/HAZARD WARNING FLASHER INDICATOR**

If the indicator flashes improperly, the signaling system is malfunctioning. Have this condition corrected as soon as possible.

Both turn signal indicator flash at once when the hazard warning flasher switch is on. (See page 4-1.)

6. WATER TEMPERATURE GAUGE

This gauge shows the temperature of the engine coolant.

If the gauge needle moves beyond the normal range area, it indicates engine overheating.

If this happens, follow this procedure:

1. Drive safely to the side of the road and stop your vehicle.
2. Turn off the air conditioner.
3. Allow the engine to idle and open the hood to permit the engine to gradually cool.
4. If the temperature does not go down with

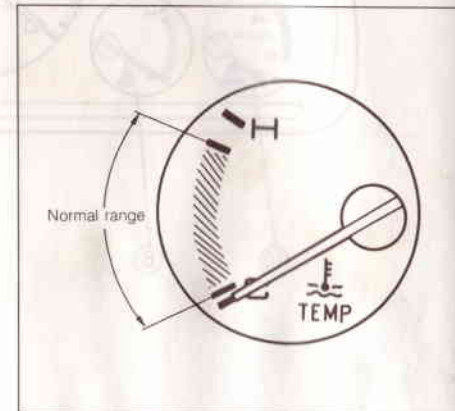

- the engine idling, shut off the engine and allow sufficient time for it to cool down.
5. Visually inspect the alternator/water pump drive belt for looseness or breakage and all cooling hose connections for leaks. If the drive belt is broken or the coolant is leaking, immediately stop the engine. Call a Mazda Dealer for assistance.
 6. If the drive belt is O.K., the engine is cool, and there are no obvious coolant leaks, the coolant level should be checked. If coolant is needed, add coolant as specified (see page 6-15 and 6-24 for cooling system).

WARNING!

Do not remove the radiator cap when the engine and radiator are hot. Scalding hot coolant and steam may blow out under pressure, which could cause serious injury. (See warning on page 6-15 for removal.)

CAUTION

If the engine continues to overheat, have the cooling system checked and repaired.

97E3 0310E

7. FUEL GAUGE

- The fuel gauge indicates how much fuel is in the tank.
- Tank capacity:
 - 72 liters (19.0 US gal, 15.8 Imp gal)

NOTE

The fuel gauge is designed to continue to indicate the amount of fuel remaining in the fuel tank even after the ignition switch has been turned to OFF.

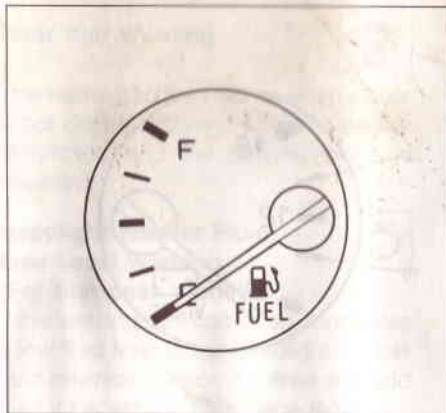

77U3 0320E

8. ENGINE OIL PRESSURE GAUGE

This gauge shows the oil pressure when the engine is running.

NOTE

The gauge will indicate a lower than normal engine oil pressure, until the engine reaches its normal operating temperature.



9. TACHOMETER

(For Non-turbo models)

The tachometer indicates engine speed in thousands of revolutions per minute (rpm)

CAUTION

Do not operate the engine within the tachometer's RED ZONE. This may cause severe engine damage.

Engine over-revolution (RED LINE) warning buzzer

A warning buzzer sounds when engine revolutions exceed $6,900 \pm 100$ rpm.

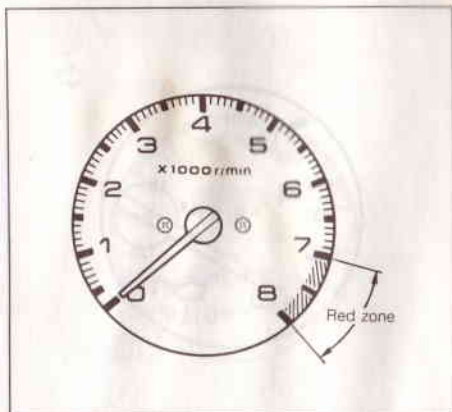

10. VOLTMETER

(Non-turbo models)

The voltmeter indicates whether the battery is charged or discharged. If the needle reads below 11 volts or above 15 volts with the engine running, it indicates the charging system needs immediate repair. It is normal for the needle to drop below 11 volts during engine starting.

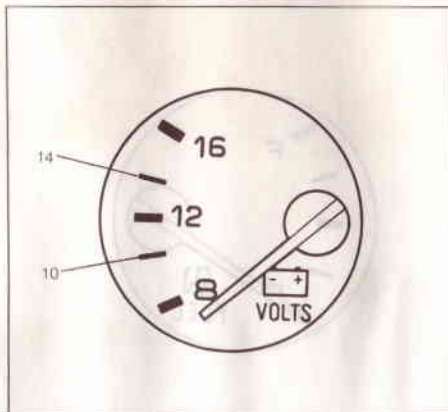

BOOST METER

(For Turbo models)

The boost meter registers at less than 0 position when the engine is idling or the vehicle is moving at extremely low speeds. When the engine speed increases, when the turbo charger is operating, or when the pressure in the intake manifold increases, the marker on the boost meter moves to a higher than 0 position.

CAUTION

When the pressure exceeds the maximum positive value shown on the meter, stop the vehicle or slow down until the meter reads normal otherwise, engine components could be damaged if you continue to drive in these conditions. Have the condition checked at your nearest Authorized Mazda Dealer as soon as possible.



11. WARNING AND INDICATOR

NOTE

Checking operation (For European models)



(Except European models)



These indicator lights are checked by turning the ignition switch ON(II) (do not start the engine) and applying the parking brake. Any light that does not come on should be checked by your Authorized Mazda Dealer.

(For European models)

Warning and indicator lights

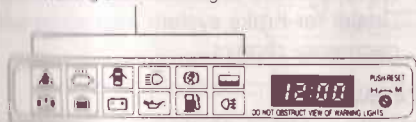

(Except European models)

Warning and indicator lights

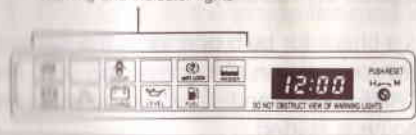

a. Hazard Warning Flasher (For European models)



This indicator light comes on when the hazard warning flasher switch is switched on.

b. Rear Glass Hatch Ajar Warning Light



(Except European models)

This warning light comes on when the rear glass hatch is not closed securely, while the engine is running and the parking brake is released.

c. Heat Hazard Warning (For European models)



See page 1-6 for detailed information.

d. Door Ajar Warning



This warning light comes on when a door is not closed securely, while the engine is running and the parking brake is released.

e. Headlight Washer Fluid Low Level Warning (For European models)



If this warning light comes on, it indicates a low fluid level in the headlight washer fluid reservoir. Check the level and add fluid if necessary. (See page 6-14.)

f. Anti-Lock Brake System (if equipped)

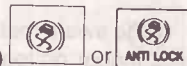

When the engine is started, the anti-lock warning light will come on. If the ABS control unit determines that all components are operating correctly, the control unit turns the anti-lock warning light off.

ABS OPERATION

The ABS control unit continuously monitors the speed of each wheel. If a wheel is about to lock up, the ABS responds by automatically releasing and re-applying the brake for that wheel. The driver will feel a vibration or pulsation in the brake pedal and may hear a 'chattering' type noise from the brake system. This is a normal condition and indicates that the ABS is operating.

CAUTION

- If the anti-lock warning light remains on while the vehicle is in motion, it indicates that the ABS control unit has detected a malfunction in the system. If this occurs, the brake system will function the same as a normal brake system without ABS. Should the anti-lock light remain on, consult your Authorized Mazda Dealer as soon as possible.

- Be aware that braking distances may be longer on loose surface layers, such as snow, which lie on top of hard surfaces, this is because the tires of a conventionally braked vehicle build up a sort of cushion of the loose layer they skid through. (See illustration)

WARNING!

The ABS cannot compensate for unsafe or reckless driving, excessive speed, following another vehicle too closely, or aquaplaning (a condition of reduced tire friction due to water on the road). Do not rely on ABS as a substitute for safe driving techniques.

Skidding wheel on vehicle with conventional brakes

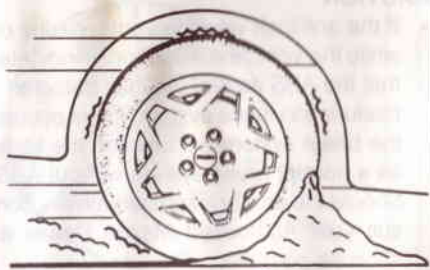

Gravel forms wedge

NOTE

When the engine is jump started in order to charge the battery, an unevenness of the engine revolutions occurs, and at the same time, the anti-lock brake system warning light flashes on and off. But this is due to the lack of battery capacity, and in no way indicates a malfunction in the system.

Under these circumstances, you should drive the vehicle only after replenishing the battery's voltage.

g. Washer Fluid Low Level Warning



If this warning light comes on, it indicates a low fluid level in the windshield washer fluid reservoir. Check the level and add fluid if necessary. (See page 6-14.)

h. Brake System Warning



This warning has two functions.

1. Parking brake warning

This light comes on when the parking brake is applied with the ignition switched on. Make sure the parking brake is fully released before driving. The light should go out when the parking brake is fully released.

2. Brake fluid level warning

If the warning light is on, the parking brake is fully released, and the ignition switched on, it indicates that the brake fluid level in the reservoir may be low.

If the warning light stays on:

1. Be sure the parking brake is released and the warning light remains on.
2. Drive safely to the side of the road and carefully stop your vehicle.
3. With the engine stopped, check the brake fluid level immediately and add fluid if required. All brake components should also be checked immediately for fluid leaks.
4. If any leaks are found, if the warning light remains on, or if the brakes do not operate properly, do not drive the vehicle. Have it towed to an Authorized Mazda Dealer for brake system inspection and necessary repairs.

WARNING!

Operation of your vehicle in the above condition is dangerous. Have the brake repaired immediately.

As a check for bulb operation, the warning light glows when the ignition key is in START position and should go out when engine is started.

l. Coolant Level Warning

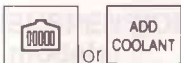

If the light/buzzer comes on while the vehicle is in motion:

1. Drive safely to the side of the road and stop your vehicle.
2. Turn off the engine and let it cool. If no coolant leaks are evident, check the coolant level in the coolant reservoir and radiator (see Warning on page 6-15). Add coolant as required.
3. If the warning light remains on, tow your vehicle to the nearest service station or Authorized Mazda Dealer.
Do not attempt to drive the vehicle if the light remains on, serious engine damage could result.

j. Alternator Warning

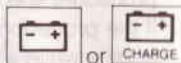

The warning indicates a malfunction of the alternator and electrical wiring system.

If the warning light comes on while the vehicle is in motion:

1. Drive safely to the side of the road and stop your vehicle.
2. With the engine stopped, inspect the alternator drive belt for looseness or breakage.

3. If the belt is operating properly, a problem exists somewhere in the charging system. It should be found and corrected as soon as possible by an Authorized Mazda Dealer.

k. Engine Oil Level Warning

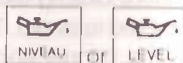

This warning indicates that the engine oil level is low.

If the light/buzzer comes on while driving:

1. Drive safely to the side of the road and stop your vehicle.
2. Check the engine oil level. If the oil level is low, add oil as required or;
3. Have your vehicle towed to the nearest gas station or an Authorized Mazda Dealer to add oil.

l. Low Fuel Level Warning

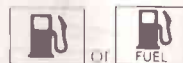

This warning indicates that the fuel level is low. The warning light will come on when the fuel level has dropped to approximately 11 liters (2.9 US gal, 2.4 Imp gal). The tank should be re-filled as soon as possible.

m. Rear Fog Light Indicator



(For European models)

This indicator lights comes on when the rear fog lights are operating.

n. Headlight High Beam Indicator



This indicator comes on when the headlights are on and in the highbeam position.

OTHER CONTROLS AND FEATURES

BONNET RELEASE

1. Pull the release knob to unlatch the bonnet.
2. Pull the safety catch lever up and lift the bonnet.

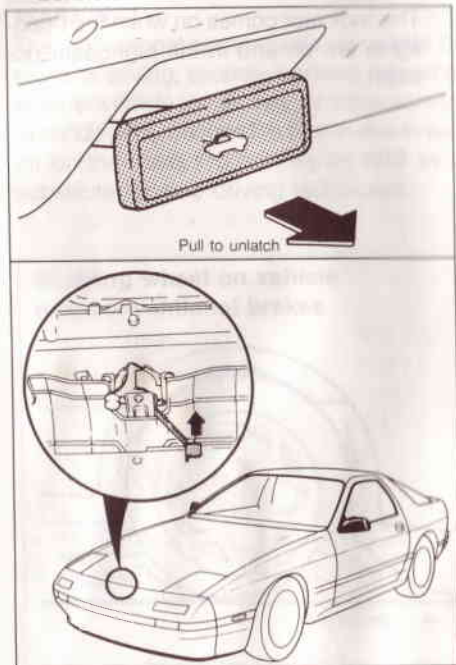

3. Hold the bonnet open with the support rod.

Before closing the bonnet, return the support rod to its clip. This prevents rattles. Lower the bonnet and make sure it locks into place.

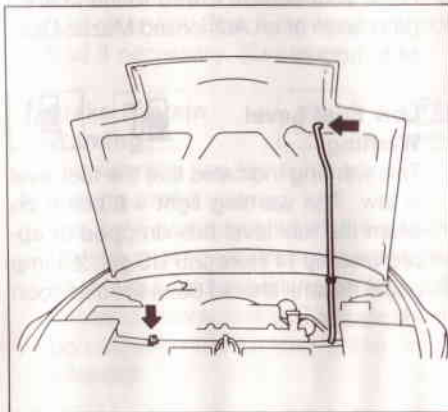

WARNING!

- Do not release the bonnet latch unless ignition is first turned off, the gear selector lever is placed in 1 (First), and parking brake is firmly set.
- If it is necessary to check beneath bonnet with the engine running, place transmission shift lever in N (Neutral); set the parking brake fully. Unexpected and possibly sudden vehicle movement may occur if these precautions are not taken.
- To avoid the possibility of personal injury, you should always turn off the ignition and remove the key before working under the bonnet unless the particular procedure specifically requires otherwise. If the procedure requires you to run the engine while working under the bonnet, do not permit any clothing, such as neckties or handkerchiefs, near the engine cooling fan. They can become entangled in moving parts and result in personal injury and damage to the vehicle. Also do not move watches, bracelets and rings. (For a more detailed explanation, see Section 6.)

AUTO ADJUSTING SUSPENSION (Except European models)

The A.A.S. System automatically changes the shock absorber damping force. Two selecting switches are provided so that the driver can tailor the damping force to the desired ride condition. The system goes one step further by providing built-in automatic control over sudden changes in the attitude of the vehicle. At either setting, the system will automatically vary the damping force through any combination of soft, firm or very firm.

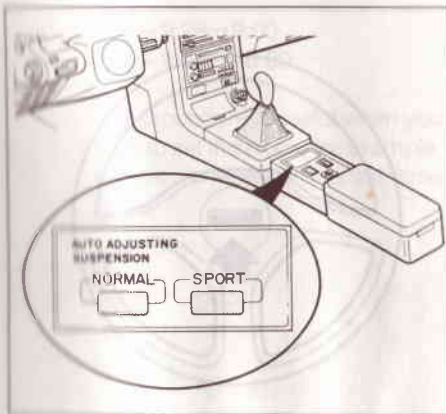

Selecting switches

NORMAL switch

At the NORMAL position, the shock absorbers provide a normal and comfortable ride. This position is suggested for ordinary driving conditions in urban areas, etc.

SPORT switch

Alternatively the shock absorbers can be set to the firm position (SPORT), ideal for sports-car-like driving conditions in which a harder setting is preferable.

Normal driving

• NORMAL switch position

At speeds of up to about 80 km/h (50 mph), the shock absorbers are in the soft condition; at speeds over 80 km/h (50 mph) the front shock absorbers change to the firm condition, thus improving directional and high speed stability. The front shock absorbers revert back to the soft condition when the vehicle's speed drops below about 70 km/h (43 mph).

• SPORT switch position

At speeds of up to about 80 km/h (50 mph), the shock absorbers are in the firm condition; at speeds over 80 km/h (50 mph), the front shock absorbers change to the very firm condition, thus improving directional and high speed stability. The front shock absorbers revert back to the firm condition when the vehicle's speed drops below about 70 km/h (43 mph).

AAS switch position	Up to about 80 km/h (75 mph)		Over 80 km/h (75 mph)	
	Front	Rear	Front	Rear
Normal	Soft	Soft	Firm	Soft
Sport	Firm	Firm	Very firm	Firm

ANTI-SQUAT EFFECT

When starting or accelerating suddenly while driving below 60 km/h (37 mph), the anti-squat function suppresses rear-end squat.

- **NORMAL switch position**

All shock absorbers change to the firm condition.

- **SPORT switch position**

All shock absorbers change to the very firm condition.

AAS switch position	Front	Rear
Normal	Firm	Firm
Sport	Very firm	Very firm

ANTI-DIVE EFFECT

The anti-dive effect suppresses front-end dive when the brakes are applied suddenly.

- **NORMAL switch position**

All shock absorbers change to the firm condition.

- **SPORT switch position**

All shock absorbers change to the very firm condition.

AAS switch position	Front	Rear
Normal	Firm	Firm
Sport	Very firm	Very firm

67U3 0380E

HORN CONTROL

The horn sounds when the horn button pressed firmly.



DIGITAL ELECTRIC CLOCK

Push and turn the reset knob to reset the time when the ignition switch is in the ACC(I) or ON(II) position.

RESET: To clear minutes, push the knob. When you release this knob, the clock will be set precisely on the hour.

If the knob is pushed while the time is between 9:01 and 9:29, the display will be reset to 9:00. If pushed while it is between 9:30 and 9:59, the display will be reset to 10:00.

9:01 ~ 9:29 → 9:00
9:30 ~ 9:59 → 10:00

This procedure is useful when you want to set the clock, for example, against a radio broadcast time signal.

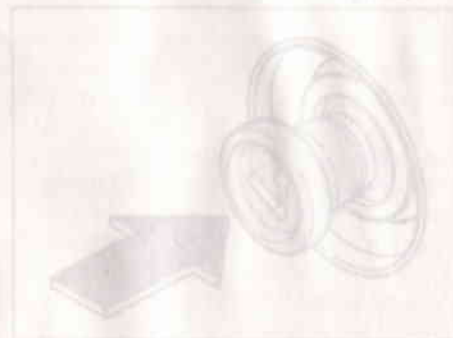

CIGARETTE LIGHTER

To operate the cigarette lighter, insert the lighter into the lighter socket. When the lighter is inserted, it will automatically lock out ready for use. If the engine is not running, the key must be in the ACC(I) position for the lighter to operate.

WARNING

- Do not take the lighter to sea. A wet lighter will not work.
- Only a genuine Yamaha lighter is approved for use. The use of other lighters may cause damage to the cigarette lighter and cause electrical shorts.
- If the lighter does not pop out within 30 seconds, remove it to prevent overheating.

CIGARETTE LIGHTER

To operate the cigarette lighter, simply press it in. When it is heated, it automatically pops out ready for use. If the engine is not running the key must be in the ACC(I) position for the lighter to operate.

WARNING!

- Do not hold the lighter in as it will overheat.
- Only a genuine Mazda lighter or equivalent should be used in the cigarette lighter socket. The use of plug-in accessories (shavers and coffeepots, etc.) may damage the socket and cause electrical failure.
- If the lighter does not pop out within 30 seconds, remove it to prevent overheating.

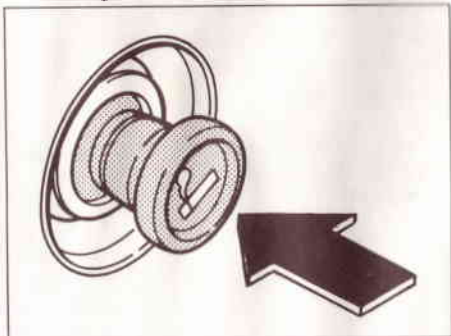

ASHTRAY

To open the ashtray, push the release catch. The ashtray should pop open automatically. To remove the ashtray, open it to the normal position, hold the lid firmly and pull the ashtray all the way out towards you. After using the ashtray, push it in fully.

WARNING!

Do not use the ashtray as a waste receptacle if it is also used for cigarettes.

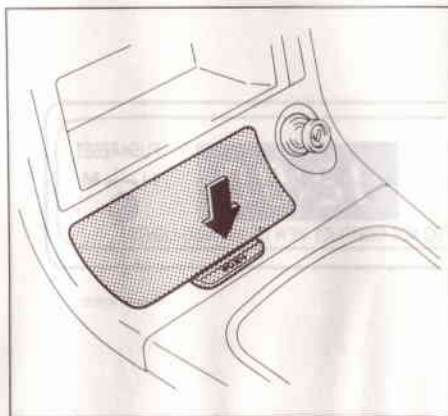

GLOVE BOX

To open the glove box, press the release catch and pull the lid downwards. If equipped with a lockable lid, insert the primary key into the slot, then turn the primary key clockwise to lock the glove box.

WARNING!

For personal safety, do not operate the vehicle with the glove box lid open.

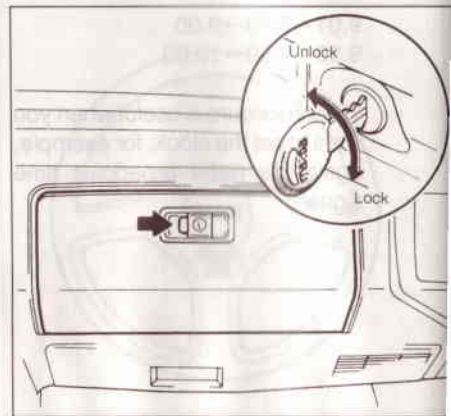

SIDE AIR VENT AND LAP LOUVER

Fresh air* or cool air (when using air conditioner) comes out of the vents and the louvers according to heater controls. (Refer to 3-30 Heating and defrosting system.) The amount and direction of air flow can be adjusted by turning the grilles of the vents and louvers.

* Except cabriolet models

Side air vent

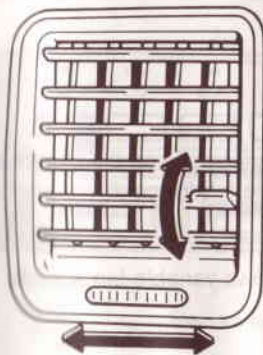

Lap louver



HEATING AND DEFROSTING SYSTEM

CONTROL PANEL AND SWITCH

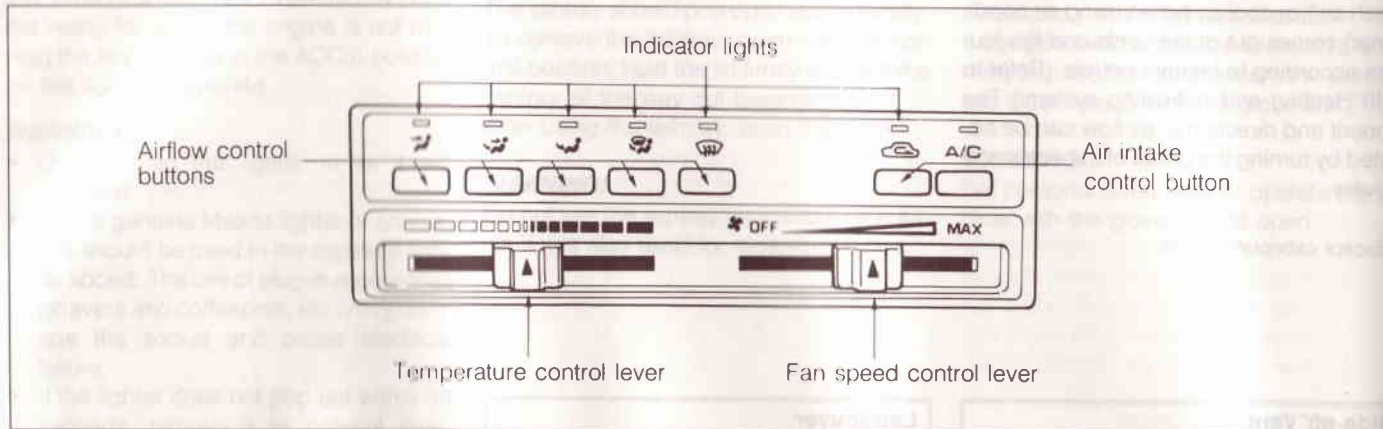

Airflow control buttons

The airflow control buttons are used to select the flow of airflow particular vents. Select the desired vent by pushing the button. An indicator light comes on to show operation.

Air intake control button

The air intake control button is used to select either fresh air from outside or recirculated air.

Push the button ON to select re-circulated air—an indicator light will come on to show operation.

Push the button OFF to obtain fresh air from outside—the indicator light will go out.

Temperature control lever

Select the desired air temperature by sliding the control lever either to the right for hot, or to the left for cold.

Fan speed control lever

The fan speed control lever allows variable fan speeds.

OFF — Fan is switched off.

HEATER CONTROLS

To shut off outside air:

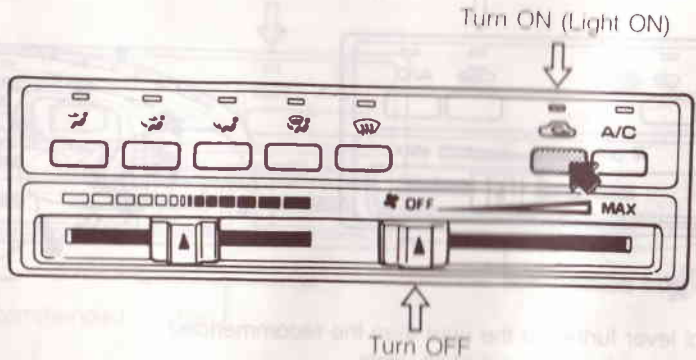

To ventilate vehicle

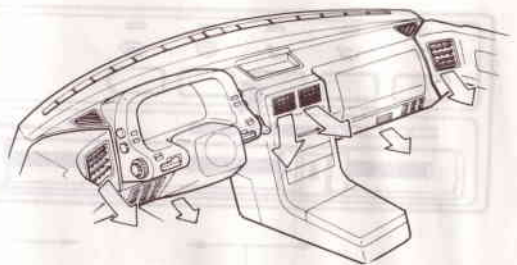
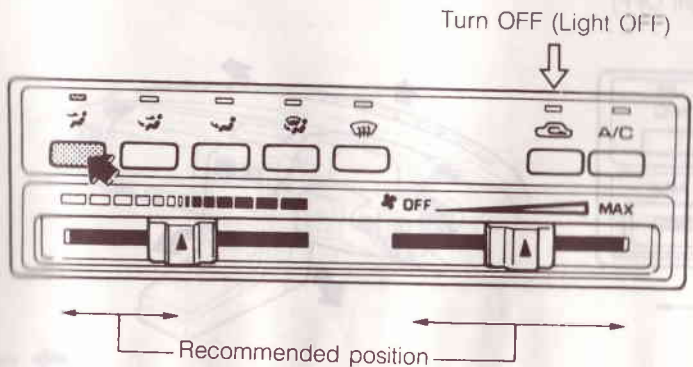

Fresh air

Bi-level operation

Turn OFF (Light OFF)

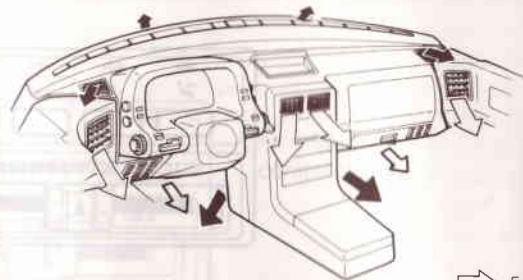
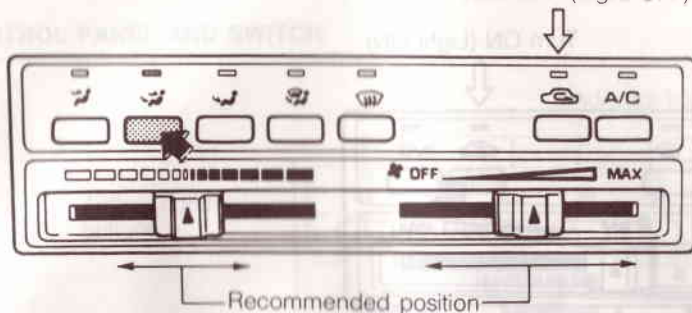

NOTE

If you set the temperature control lever further to the right than the recommended position shown in the illustration warm air comes out of all vents.

↖ Fresh a
↘ Warm a

To heat vehicle

Turn OFF (Light OFF)

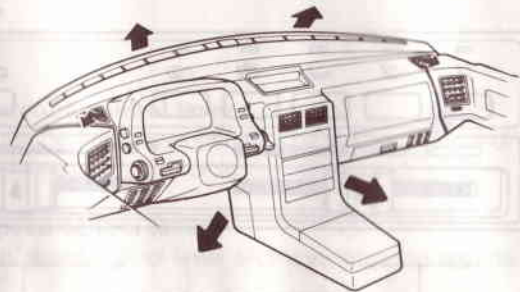
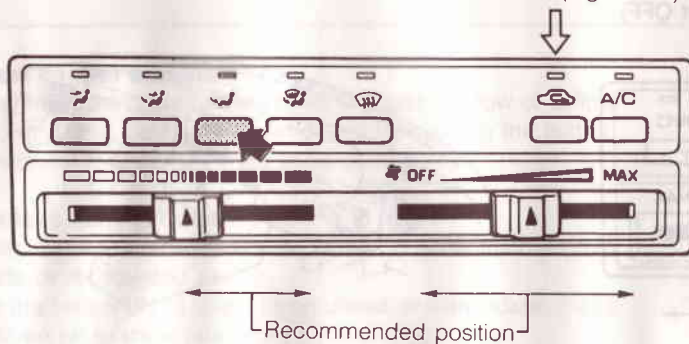

↘ Warm a

To defrost and defog windshield

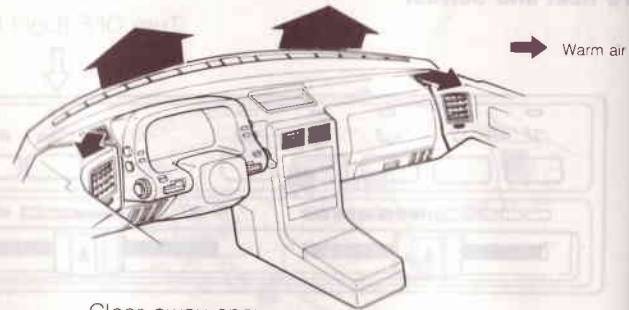
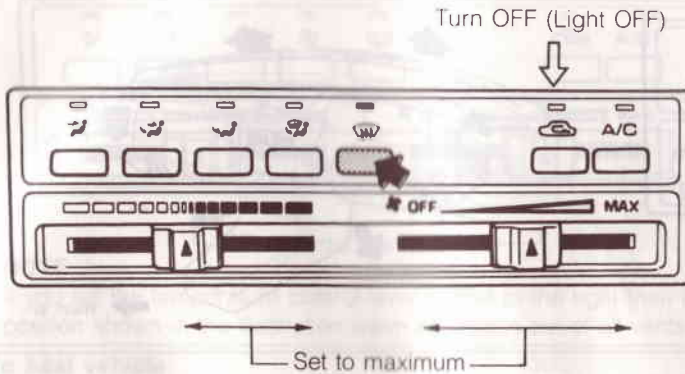

Clear away snow

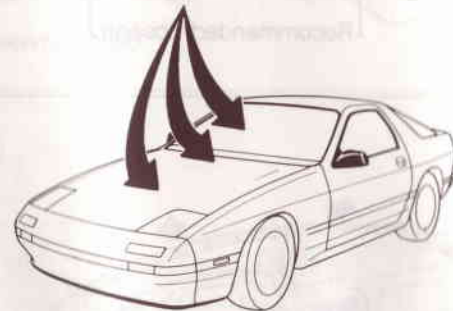

- For maximum defrosting

1. Press the airflow control button .

NOTE

The inflow of outside air is shut off and air is recirculated inside the vehicle when you press the  button. Ventilation is not possible in this setting; therefore, the windows will tend to fog easily.

2. Set the fan speed control lever to the MAX position.
3. Set the temperature control lever to the extreme right position.

- Clear windshield, rear glass, outside mirrors, and all side windows of ice and snow before driving vehicle.
- Clear snow and ice from the hood and air inlet in the cowl grille to improve heater and defroster efficiency, and to reduce the probability of fogging on the inside of the windshield.
- Use of air conditioner is effective for defogging (if equipped).

AIR CONDITIONER (if equipped)

To operate air conditioner:

1. Set the temperature control lever to the desired position.
2. Start the engine. Turn on the air conditioner switch and set the fan speed as desired.
3. When maximum cooling is needed, push the air intake control button to ON (indicator light comes on), then set the fan speed control lever to the maximum position.

AIR CONDITIONER SWITCH

Pushing this switch turns the air conditioner on or off. An indicator light illuminates when the air conditioner is on.

NOTE

If the air conditioning system is not to be used for one month or more, start the vehicle and operate the air conditioning system for a few minutes each week, to lubricate the inside of the compressor.

Operating Tips for the Air Conditioner System

- If the vehicle has been parked in direct sunlight, open the windows to let warm air escape before operating the air conditioner.
- To clean misted windows on rainy days, decrease the temperature inside the vehicle by operating the air conditioner.
- When driving in heavy traffic, insufficient cooling may occur because of extended idling periods. In this case, drive in a lower gear to obtain sufficient cooling.
- Be sure to have the air conditioning system checked and serviced in both hot and cold seasons.

Airflow control buttons

Indicator lights

Air intake control button

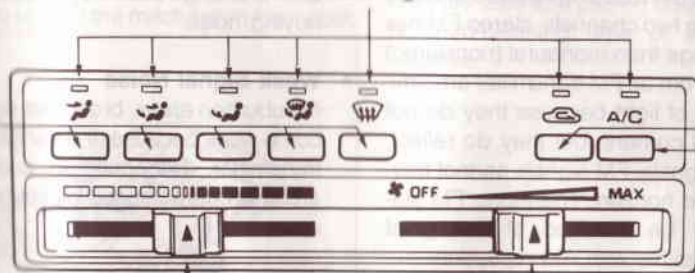

Temperature control lever

Fan speed control lever

Air conditioner switch

AUDIO SYSTEM (if equipped)

AM/FM MULTIPLEX RADIO

DIVERSITY TUNING

The rear power antenna receives both AM and FM signals, while the windshield antenna receives only FM broadcasts. After signals have been received from both the front and rear antennas the antenna providing the best FM reception selected. This is known as diversity tuning. With this method you will be able to enjoy the highest quality FM reception.

NOTE

Rear power antenna elevation is fully automatic. With the ignition switch in ON(II) or ACC(I) position, the antenna will elevate whenever the radio is turned on and will retract when the radio or the ignition switch is turned off.

If the tape is operated after the radio is turned on, the antenna will stay raised. When the tape is turned off, the antenna will be retracted.

RADIO RECEPTION

AM (Amplitude Modulation) characteristics

AM signals bend around such things as buildings or mountains and bounce off the ionosphere. Therefore, they can reach longer distances than FM signals. Because of this, two stations may sometimes be picked up on the same frequency at the same time.

FM (Frequency Modulation) characteristics

An FM broadcast range is usually about 40—50 km (25—30 miles) from the source. Because of the extra coding needed to break the sound into two channels, stereo FM has even less range than monaural (nonstereo) FM. Signals from an FM transmitter are similar to beams of light because they do not bend around corners, but they do reflect. Unlike AM signals, FM signals cannot travel beyond the horizon. Therefore, FM stations cannot be received at the great distances possible with AM reception.

Atmospheric conditions can also affect FM reception. High humidity will cause poor reception. However, cloudy days may provide better reception than clear days.

- **Multipath Noise**

Since FM signals can be reflected by structures, it is possible to receive both the direct signal and the reflected signal at the same time. This causes a slight delay in reception and may be heard as a broken sound or a distortion. This problem may also be encountered when in close proximity to the transmitter.

- **Flutter/Skip Noise**

Signals from the FM transmitter move in straight lines and become weak in valleys between tall buildings, mountains, and other obstacles. When a vehicle passes through such an area, the reception conditions change suddenly, resulting in annoying noise.

- **Weak Signal Noise**

In suburban areas, broadcast signals come weak because of distance from transmitter. Reception in such fringe areas is characterized by sound break-up.

- **Strong Signal Noise**

This occurs very close to a transmitter tower. The broadcast signals are extremely strong, so the result is noise and sound break-up at the radio receiver.

• **Station Drift Noise:**

When the vehicle reaches the area of another strong station broadcasting at a similar frequency, the original station may be temporarily lost and the radio will begin to pick up the second station. At this time there will be some noise from this disturbance.

TAPE AND TAPE PLAYER CARE

- Only cassette tapes that play no longer than 90 minutes should be used. Tapes exceeding 90 minutes are thin and may easily break.
- Do not leave a tape cassette in the tape player slot when not in use. Remove it completely to permit the slot door to close and to protect the mechanism from dust.

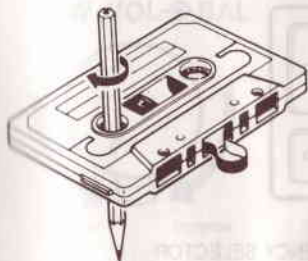

- Store cassettes away from extreme heat and direct sunlight. Protect the exposed tape from dirt and damage. Store tapes in their original cases or other protective cases.
- If the tape is loose, it may produce poor sound or performance during playback. Use a pencil or other thin instrument to remove the slack if necessary.

Cleaning the Tape Player

Over time, the tape head, capstans, and pinch rollers gather oxide residue from the tape as it passes these components while playing. This oxide accumulation can cause weak or wavering sound and damage to the cassette tape and player. Use a good quality head-cleaning tape or liquid cleaner cassette.

Radio with Cassette tape player

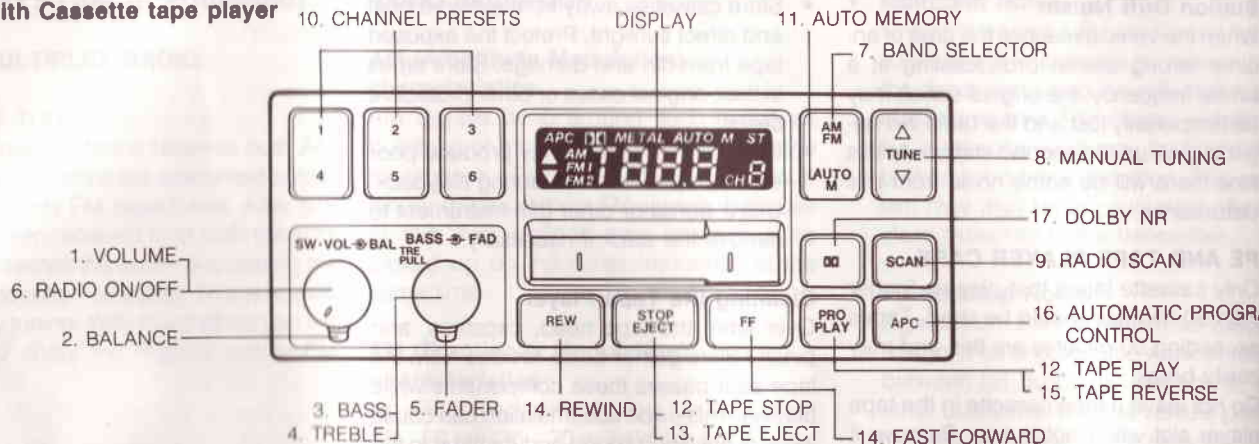

Graphic equalizer

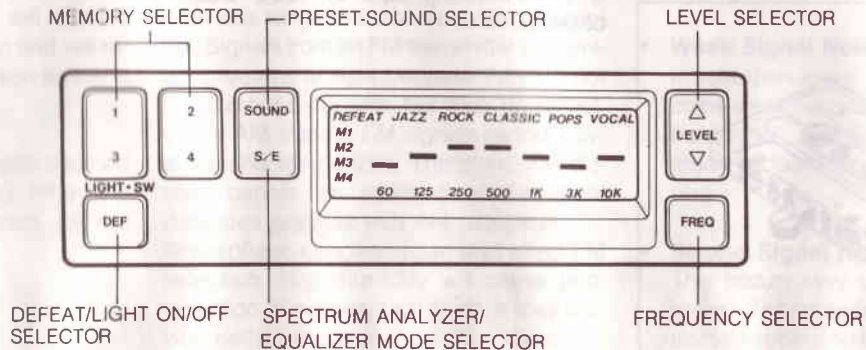

1. VOLUME

Turn the knob to adjust the volume.

2. BALANCE

This control adjusts the sound distribution between the right and left speakers. Turn it clockwise to shift the sound to the left speakers; counterclockwise to shift the sound to the right speakers.

3. BASS

This controls the lower tonal qualities. If your listening preference is for more lows, turn the control clockwise; for less lows, turn the control counterclockwise.

SW · VOL ↻ BAL



Decrease

Increase

SW · VOL ↻ BAL



Left

Right

BASS ↻ FAD
TRE
PULL



Decrease

Increase

4. TREBLE

Pull and turn the knob to control the higher tonal qualities. If your listening preference is for more highs, turn the control clockwise; for less highs, turn the control counter-clockwise.

5. FADER

Turn the knob clockwise to gradually shift the stereo sound to the rear speakers; counter-clockwise to shift it to the front.

RADIO OPERATION

6. RADIO ON/OFF

To operate the radio, turn the ignition switch to ACC or ON.

To select radio operation, press the knob (you need to eject tape), it will revert to the previously selected station and its frequency will be displayed. Press again to turn the radio off.

NOTE

This system does not revert to previous mode when ejecting the tape.

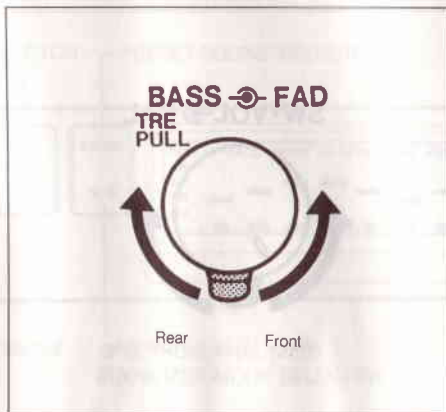
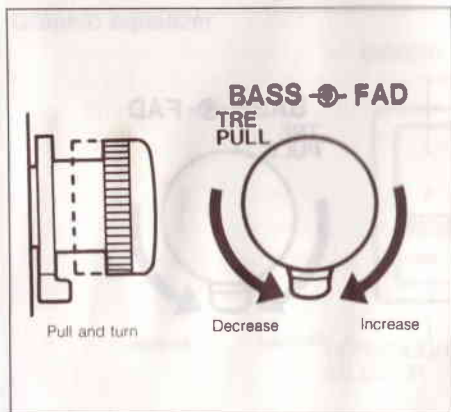

7. BAND SELECTOR

Press AM/FM to choose either an AM or FM. Pressing AM/FM alternates AM, FM1, and FM2. The corresponding indicator will light.

If an FM stereo broadcast is being received, ST will be displayed in the display.

NOTE

If the FM broadcast signal being received becomes weak, reception automatically changes from STEREO to MONAURAL for reduced noise, and the ST indicator will go out.



8. MANUAL TUNING

To manually tune a station, press Δ for a higher frequency, and press ∇ for a lower frequency.

Holding either switch down for more than one second and releasing will begin automatic seeking of the next receivable higher or lower frequency station.

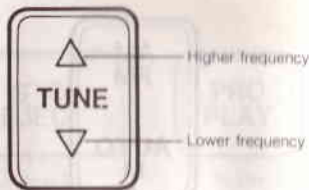

9. RADIO SCAN

Press the SCAN to automatically sample strong stations. Scanning stops at each station for about five seconds. To hold a station, simply press SCAN again during this five seconds.



10. CHANNEL PRESETS

The three channel preset buttons can be used to store, 6 AM and 12 FM stations. First select AM, FM1, or FM2 by pressing the AM/FM. AM, FM1, or FM2 will be displayed. Tune the desired station and depress one of the channel preset buttons. Hold the button until a beep is heard and sound returns. The channel number and station frequency will be displayed. The station is now held in memory. Repeat this operation for other stations and bands.

To tune a desired station, press the corresponding preset channel button. The station frequency and preset channel number will be displayed.

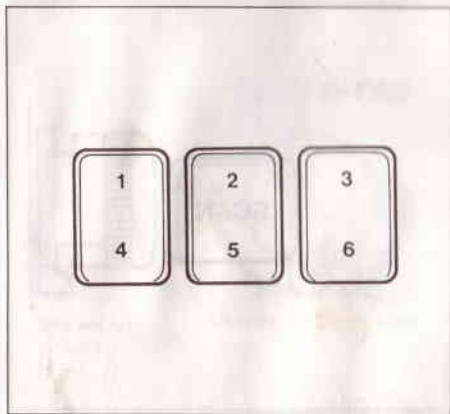

11. AUTO MEMORY

This is particularly useful when driving in an area where you do not know the local stations. Supplemental AM/FM stations can be memorized in addition to the preset stations.

Press and hold AUTO M for about two seconds. The system will automatically scan and temporarily store the six strongest stations of the selected band in that area. After scanning is completed, the strongest station will be tuned and its frequency will be displayed.

If a total of six stations cannot be tuned after scanning operations, the letter A will be displayed on the indicator.

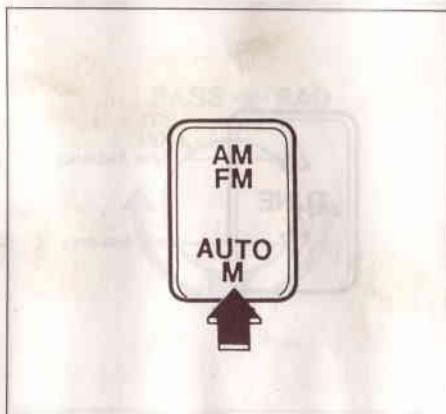

Press and release the AUTO M to recall preset stations from the auto memory. The preset station will be selected with a beep.

CASSETTE TAPE PLAYER OPERATION

Insert the cassette through the cassette slot, open edge to the right, to play. This automatically switches the unit from radio/compact disc to tape operation. TAPE will be displayed. At the end of the tape, the unit will automatically reverse the tape play.

When the upper triangle (▲) in the display is lit, the top side of the tape is being played. When the lower triangle (▼) is lit, the bottom side of the tape is being played.

NOTE

When Metal or Chrome equivalent tape is inserted, the player will automatically adapt to it and METAL will be displayed.

Cassette Player Protection

To prevent possible damage to the cassette player if a damaged or excessively tight tape is inserted, the cassette will be ejected and the TAPE indicator will flash. If the cassette cannot be ejected, the tape player will go to the pause mode.

If operation of the unit is not normal, contact your Authorized Mazda Dealer. Never attempt to repair the unit or insert a screwdriver, etc., to remove a stuck cassette.

12. TAPE PLAY/STOP

To stop tape play during playback without ejecting the tape, press STOP/EJECT. The tape will be in a pause mode. By pressing the PRO/PLAY button, tape play restarts. To listen to the tape directly from radio mode while the tape is inserted, press PRO/PLAY.

13. TAPE EJECT

The tape can be ejected while in the pause mode by pressing STOP/EJECT.

To eject the tape while it is being played, press this button twice.

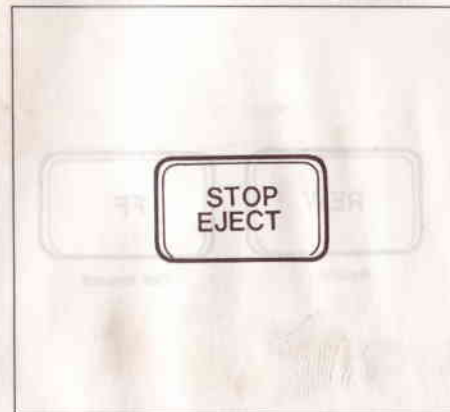

14. FAST FORWARD/REWIND

Press FF or REW to operate. The tape direction indicator will flash while the tape is in fast forward or rewind. To stop this operation, press STOP/EJECT.

15. TAPE REVERSE

To change tape play direction, press PRO/PLAY.

When the upper triangle (▲) in the display is lit, the top side of the tape is being played. When lower triangle (▼) is lit, the bottom side of the tape is being played.

NOTE

At the end of the tape, the unit will automatically reverse the tape play.

16. AUTOMATIC PROGRAM CONTROL

This is used to locate the beginning of present or next program or skip unrecorded sections of a tape.

The APC circuit senses silent portions between programs. Press APC to operate. APC will be displayed. Press Fast Forward or Rewind to automatically advance to beginning of the next program or to return to the beginning of the program being played. The tape direction triangle and APC will flash while the beginning of the program is being sought.

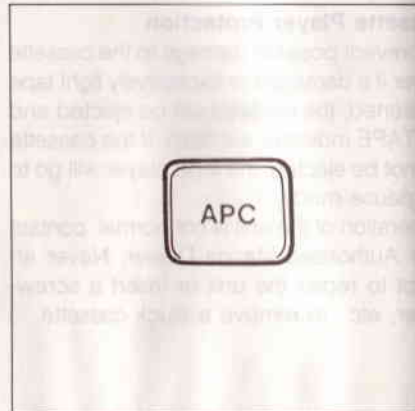
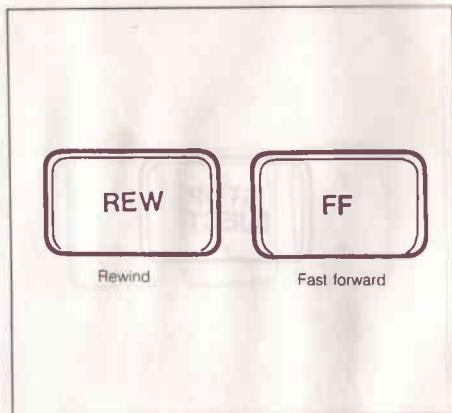

NOTE

APC may not operate properly when the following types of tape are used:

- A tape with low recording level.
- A music tape having long silent interludes.
- A music tape of a live recording having no intervals of silence between tunes.

17. DOLBY NR (NOISE REDUCTION)

When using a tape encoded with Dolby NR*, press the Dolby NR button. The  symbol will be displayed. To play a tape recorded without Dolby NR, push the button once again.

*Noise reduction system manufactured under license from Dolby Laboratories Licensing Corporation.

Dolby and the double-D symbol  are trademarks of Dolby Laboratories Licensing Corporation.

GRAPHIC EQUALIZER

The graphic equalizer is an expandable tone control which gives the user a more finite control of the tonal response of the entertainment system. Each of seven frequency ranges are adjustable. This greater flexibility enables the user to tailor the sound to his/her individual taste.

There are three ways to select the desired tonal response:

Preset sound: Preset in unit.

Memory: Set into memory by user.

Manual: Set by user.

NOTE

When the equalizer is on, the Bass/Treble knob has no effect on sound quality.

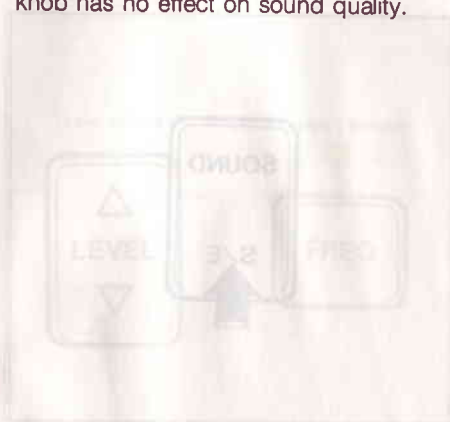
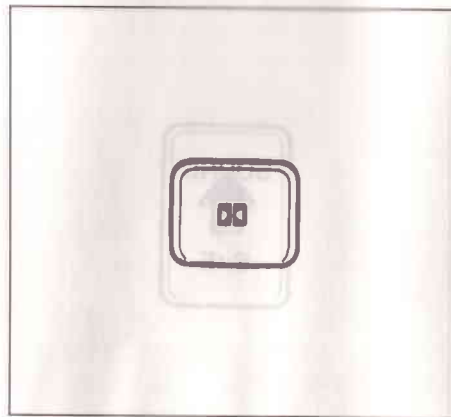

Spectrum Analyzer/Equalizer Mode Selector

Spectrum analyzer mode

Pressing the button to the spectrum analyzer mode enables the user to see the frequency band output of the music being listened to in this mode selected.

Equalizer mode

Pressing the button to the equalizer mode enables the user to see the selected adjustment level of the various frequency ranges in this mode selected.

Preset Sound Selector

Pressing the button to the preset sound mode allows the user to select the output characteristics for the type of music being played. There are five selections that fit the average listener's expectations.

SETTING	CHARACTERISTICS
JAZZ	Extended high range and emphasized transient response.
ROCK	Characteristics adapted to high speed, intense sonic changes.
CLASSIC	Balanced response for different instruments together with a sense of scale and impact of a large performance hall.
POPS	Slight echo for emotional response in vocals.
VOCAL	Vocals reproduced with maximum fidelity.

These are only suggested positions. No damage will result to the sound system if the sound selector is not set to match the music (i.e., VOCAL position for classical music).

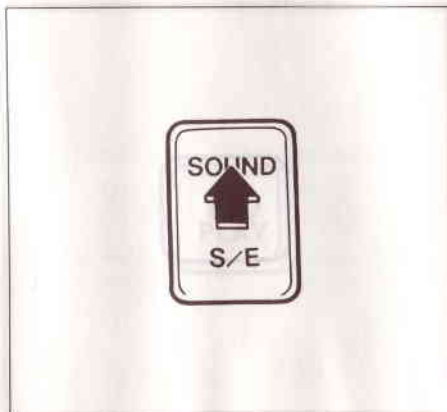
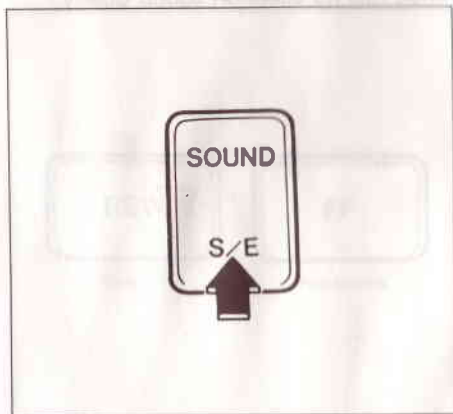

Defeat/Light ON-OFF Selector

To control operation of the graphic equalizer, press this button to select defeat mode ON or OFF.

Defeat is shown in the equalizer display when selected.

Hold the button for about two seconds to select ON or OFF of the graphic equalizer display.



Manual Adjustment of Frequency Bands

1. Press the Frequency Selector to change the unit to the manual adjustment mode regardless of the previous mode selected.
2. Select the band to be set. Each subsequent press of the button selects a band from 60 to 10K. The indicator bar of the band selected will flash for about 30 seconds.
3. Adjust the output level of the selected band up or down by pressing the Level Selector within 30 seconds.

NOTE

- The level changes one division of the scale each time the button is pressed.
- The output frequency remains as adjusted until canceled by pressing the Memory or Preset Sound Selector.

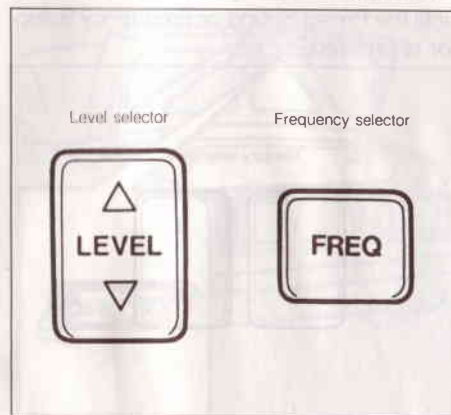

Setting Memory

Four adjustable memory selections are available to set for recall manually adjusted frequency range output patterns. These can be used in addition to the preset ranges.

1. Press the Frequency and Level selectors to adjust the bands as desired as outlined.
2. Press either Memory Selector button for at least two seconds until M1—M4 appears on the equalizer display. Set M1—M4 as desired.
3. Press the desired number button to recall the memorized pattern after setting.

NOTE

The output frequency remains as selected until the Preset Sound or Frequency Selector is pressed.

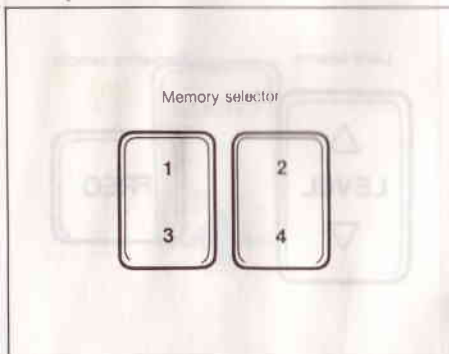

Frequency range explanations

60 Hz

This controls the super low frequency sounds. This can prevent masking caused by road noise.

125 Hz

This controls the low frequency range. It can be used to accentuate bass sounds. In addition, by lowering this frequency range, muddied sound response from the speakers is minimized.

250 Hz

This controls the mid/low range which is the central area for musically rhythmic instruments, such as the drum and bass.

500 Hz

This controls the mid range frequencies which are the central area for most musical instruments and human voices.

1 kHz

This controls the mid range (above 500 Hz).

3 kHz

This controls the frequency range that significantly affects hearing perception. When the frequency range is too high, it will produce a hard and metallic sound.

10 kHz

This controls the higher frequencies. It can be used to improve the sheen and clarity of sound reproduction.

INTERIOR LIGHT AND MAP LIGHT (If equipped)

INTERIOR LIGHT

1. OFF — Light off.
2. DOOR — Light on when door is open.
3. ON — Light on.

MAP LIGHT

4. The map lights are switched on or off individually by pushing the outside of each light frame.

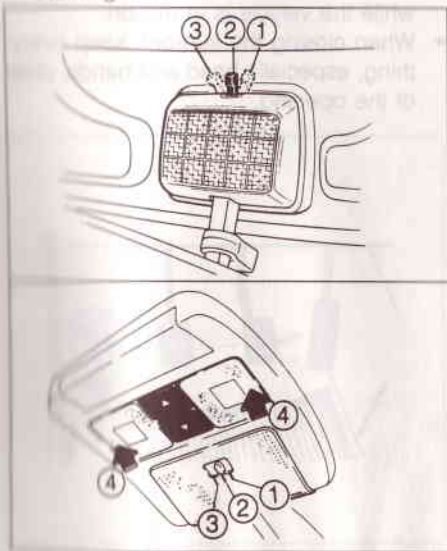

LUGGAGE COMPARTMENT LIGHT

(Except cabriolet models)

1. OFF — Light off.
2. ON — Light on when rear glass hatch is open.

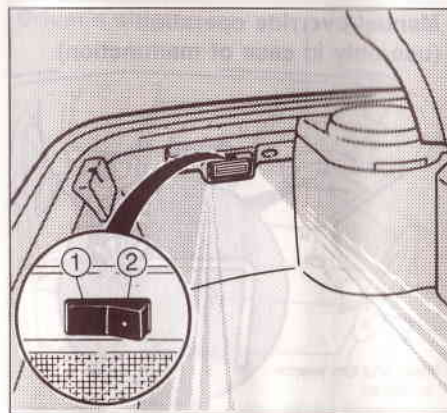

(Cabriolet models)

This light automatically comes on when the trunklid is opened, and goes off when closed.

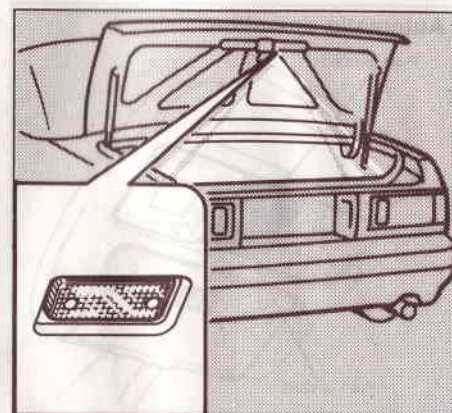

POWER SLIDING SUNROOF (if equipped)

The power sliding sunroof can be either tilted up or opened and closed electrically. To tilt up, press the rear button and the panel will tilt up. Release the button and press it again to slide the roof open. The sunroof can be partially opened to any position simply by releasing the button when the desired opening is reached.

To close, press the appropriate button, as illustrated.

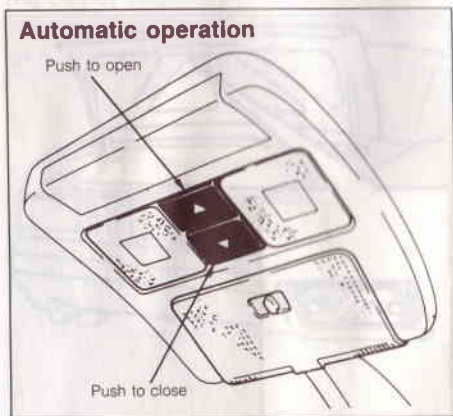

NOTE

- Release the switch as soon as the sunroof slides fully opened or closed. If kept on, the sunroof may be damaged.
- Make sure that the sunroof is fully closed when leaving the vehicle unattended.
- Do not open the sunroof soon after it has rained or after the vehicle has been washed, as the water remaining around the edges may drip down inside your vehicle.

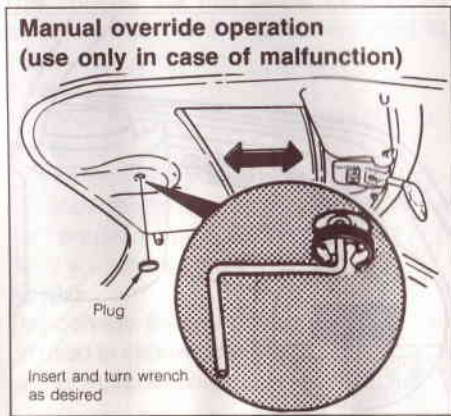

NOTE

- Periodically remove any dirt that may have accumulated on the guide rail.
- If the sliding sunroof malfunctions, it can be opened or closed manually with the hex-head wrench furnished in the glove box. See the illustration for additional details.

WARNING!

- Do not extend anything, especially head and hands, through the open sunroof while the vehicle is in motion.
- When closing the sunroof, keep everything, especially head and hands, clear of the opening.

FOOT REST (if equipped)

A convenient foot rest is provided for the driver's left foot.



87U3-0610E

COAT HOOK (Except cabriolet models)

WARNING!

Do not hang anything on the coat hook in such a manner that the driver's view is obstructed.

Driver's side



CONVERTIBLE TOP

Names of parts involved in the operation of the Convertible top.

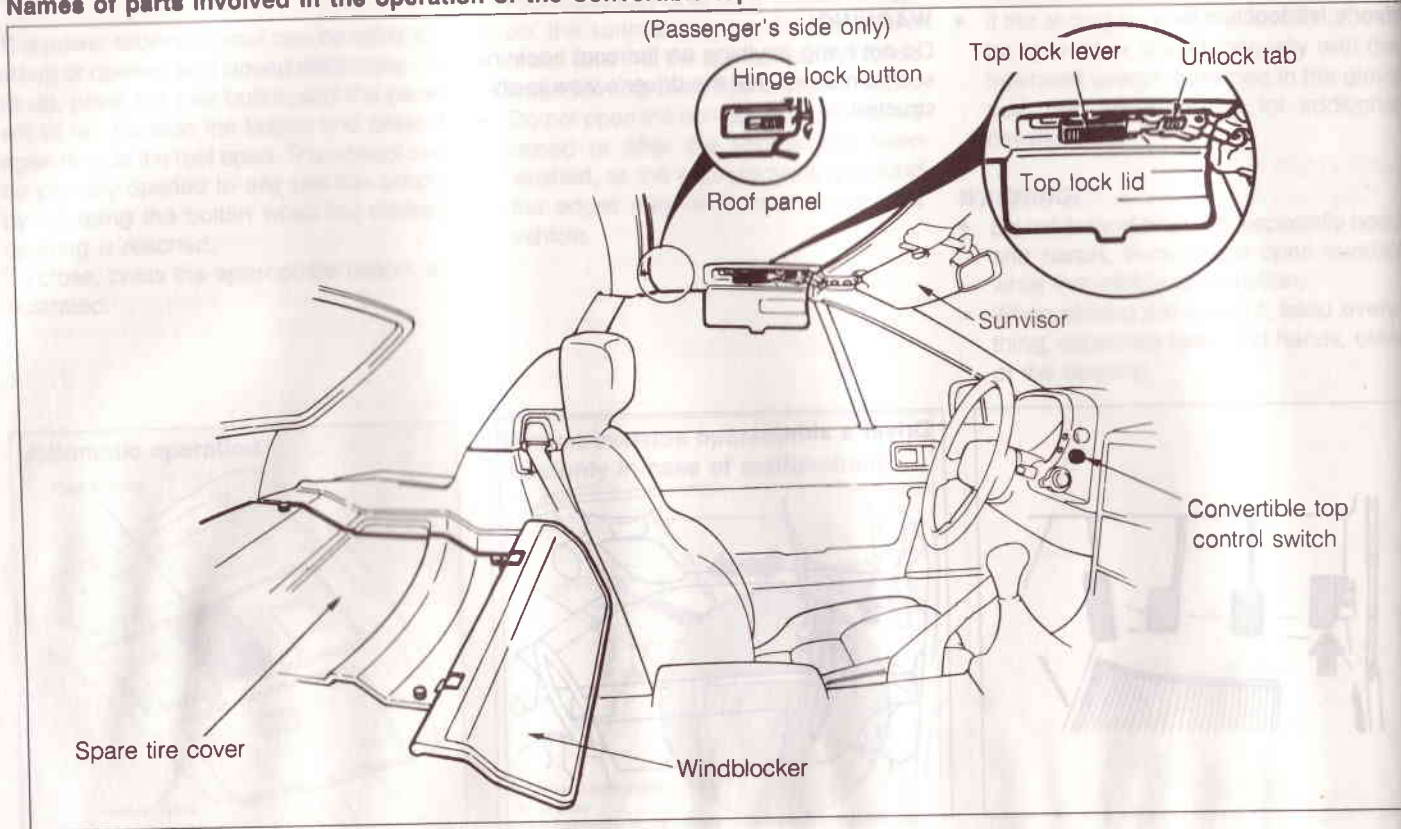

Convertible top precautions

Be sure to read the following precautions prior to cabriolet operation.

- Before lowering or raising the top, be sure to park on a level surface and stop the vehicle in a safe place out of the way of traffic.
- Operation of the cabriolet is possible with the ignition switch in the ON(II) position (and with the parking brake set). However to prevent the battery from discharging, it is best to operate the top while the engine is running.
- Take care so that objects inside the vehicle are not blown away by the wind when the top is lowered.
- Do not permit passengers to stand while the vehicle is in motion.
- Do not sit on the folded cabriolet. Sitting or placing objects on the folded top could result in bodily injury from a fall, or damage to the top.

- To prevent burglary and vandalism of the vehicle, and to insure that the passenger compartment does not get wet in the event of sudden rain, close the top securely and lock all doors whenever leaving the vehicle.
- Do not operate the cabriolet when the temperature is below 5°C (41°F), as this will damage the top material.
- When lowering the cabriolet, make sure the rear defroster switch is turned OFF.
- Do not lower the cabriolet when it is wet. It can cause deterioration and shrinkage of the top if allowed to dry while folded. Lowering the top while it is wet can cause water to drop into the passenger compartment, resulting in mold or mildew.
- When the cabriolet is lowered or the roof panel is opened, be careful not to hurt yourself against the edge of the front pillar while getting in or out of the vehicle.

Convertible top warning beeper

The cabriolet has two sound warning systems, as described below.

1. Operating sound
When activating the switch, a slowly repeating beep will begin to signal the cabriolet's operation. Operation of the cabriolet switch will begin about three seconds after the switch is activated. A 1-second long beep will sound when the top is fully lowered or raised.
2. Warning sound
When the parking brake is not set or if the switch is activated when the vehicle is in motion, a rapidly repeating beep will warn that the cabriolet cannot be lowered or raised under these circumstances.



LOWERING THE CONVERTIBLE TOP

1. Set the parking brake and shift the transmission select lever to NEUTRAL.
2. Turn the ignition switch to the ON(II) position.
3. Lower the side windows.
4. Pull down the sunvisors.

5. Remove all objects on the spare tire cover when lowering the convertible top, otherwise the top or the objects on the spare tire cover could be damaged.
6. Open both top lock lids. Push the unlock tabs and release top lock levers.

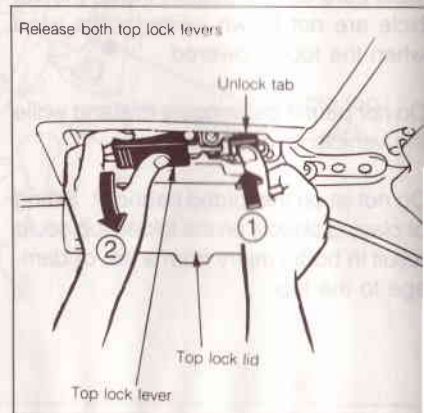
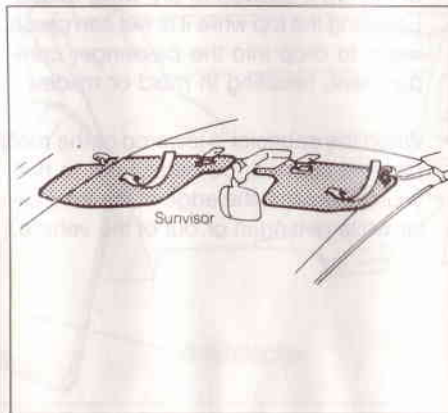
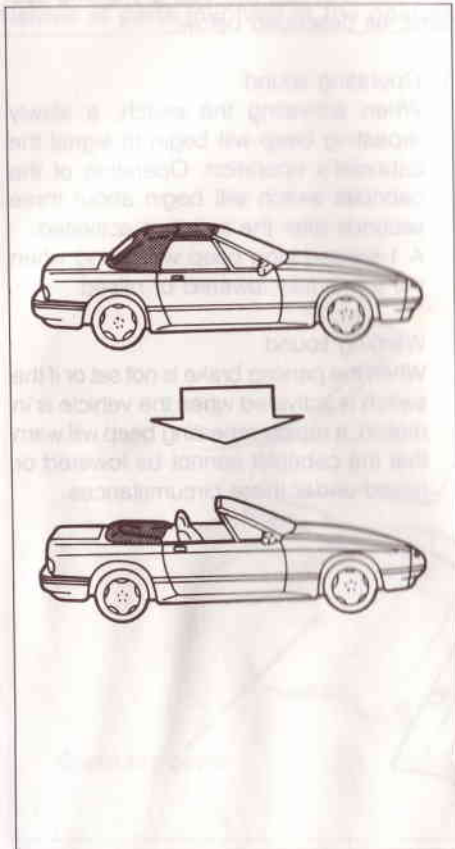

7. Rotate the convertible top control switch rearward (toward you) until the beeping stops. When the cabriolet is lowered about one-third of the way, however, lowering action will stop as a safety check. At this time, release the switch and after making sure operation is safe and normal, you may rotate the switch rearward once again and complete lowering.

NOTE

Even if you rotate the convertible top control switch, the convertible top cannot be lowered (or raised) when the parking brake is not set (the warning sound will be heard). (see page 3-53, cabriolet warning beeper)

8. Fold the roof panel forward as described in the following steps:

1) Fold the seatbacks forward to prevent contact with the roof panel.

2) Retract both top lock levers to LOCK position, then close the top lock lids.

CAUTION

Never fold the roof panel without retracting both top lock levers to LOCK position and closing the top lock lids, otherwise the inner trim will be damaged.

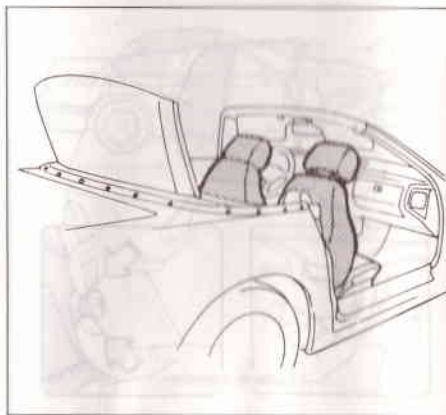
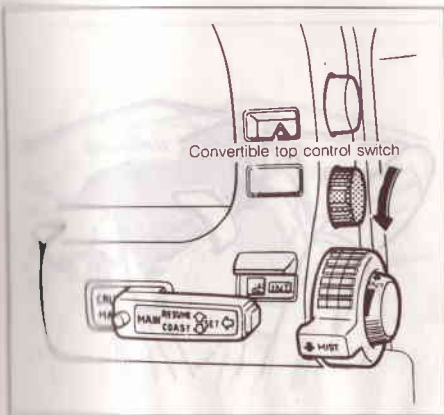

- 3) Slide the hinge lock button (passenger's side only) in the direction of the arrow.

Push and hold the button, then fold the roof panel slowly forward,

9. Cover the convertible top with top boot stored in the trunk. Affix it to the snaps provided.

CAUTION

- Never activate the switch when the top is covered. This will damage both the boot and the convertible top motor.
- Never drive with the top partially folded and uncovered.
- Press the snaps on as shown to prevent breaking the snaps. Do not press the tops of the snaps.

NOTE

Place the top boot on the convertible top whenever it is fully lowered.

10. To minimize the air turbulence inside the passenger compartment, and to improve heating capability in cold weather driving, raise the windblocker located behind the seats as described below;

- 1) Lean the seatbacks forward.
- 2) Lift the windblocker to its rearward position.

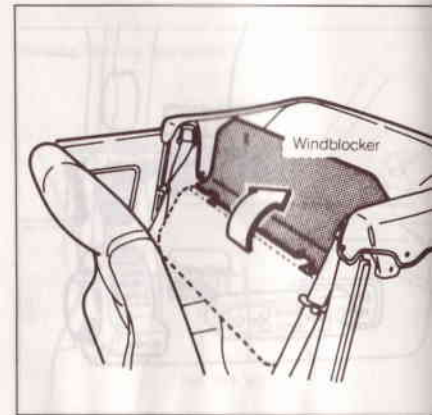
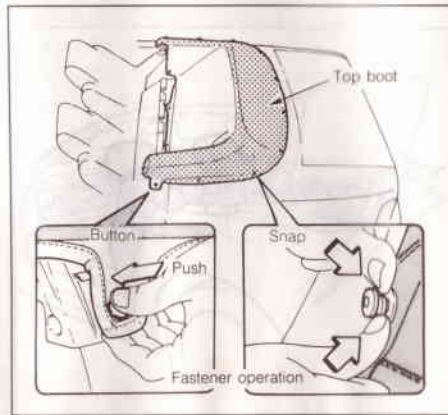
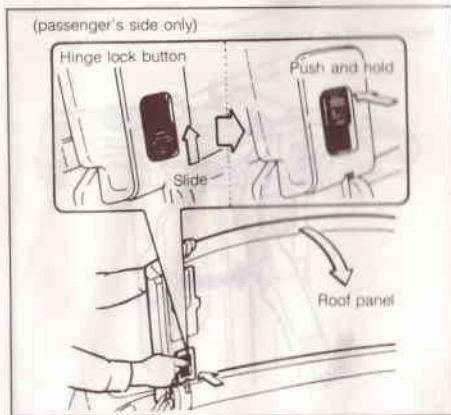

- 1) Raise the seatbacks to their original positions.
- 4) Lean the windblocker against the seatbacks.

NOTE

If the seatback in the front or rear seat is in the upright position, the windblocker will not fit up in the seat. In this case, adjust the seatback to the upright position.

RAISING THE CONVERTIBLE TOP

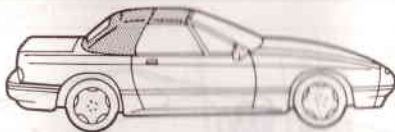
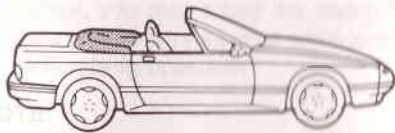

1. Set the parking brake and shift the transmission select lever to NEUTRAL.
2. Undo the snap fasteners, remove the top boot and store it properly in the trunk.

NOTE

Do not touch the top of the car with your hands or feet. Do not touch the top of the car with your hands or feet. Do not touch the top of the car with your hands or feet.

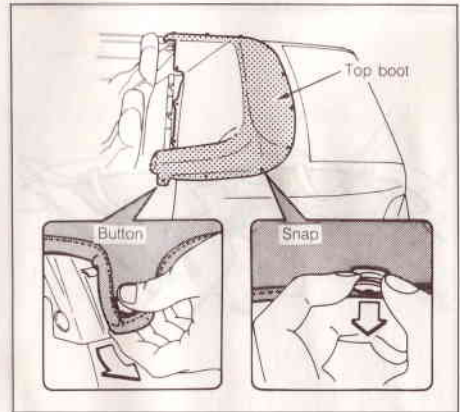
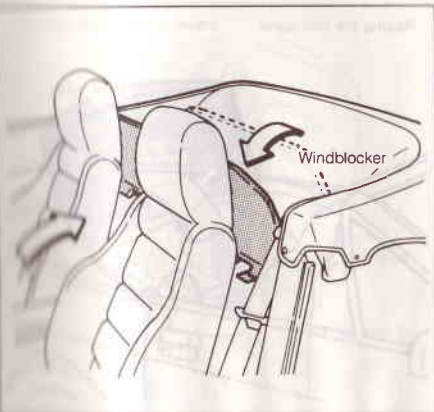

3. Turn the ignition switch to the ON(II) position.
4. Lower the side windows.
5. Pull down the sunvisors.

6. Lower the windblocker as described below;

- 1) Incline the seatbacks.
- 2) Lower the windblocker.



NOTE
 Make the seat back fully reclined and
 windblocker fully lowered.

7. Lift up the roof panel until it clicks into place.

NOTE

If the seats are in the fully reclined position the roof panel will contact seatbacks and not lift up. In this case, either fold the seatback or slide the seats forward.

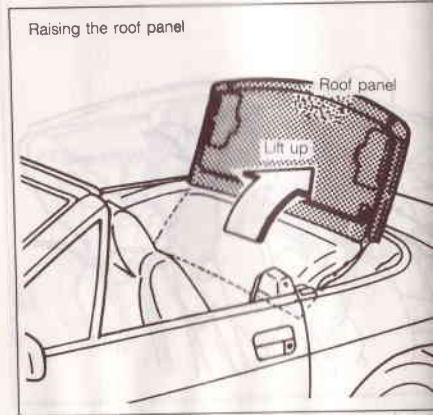
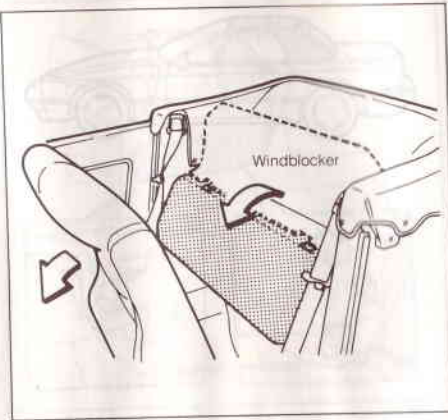
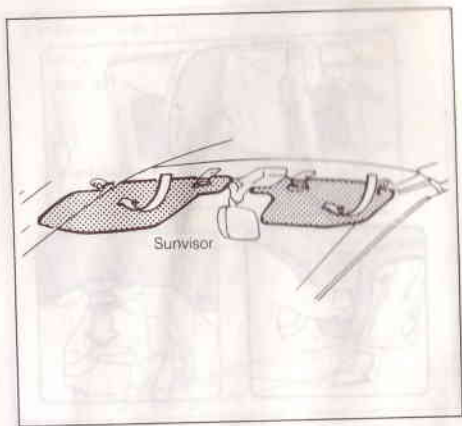

8. Open both top lock lids. Push the unlock tabs and release the top lock levers.

9. Rotate the convertible top control switch forward (away from you) until the beeping stops. When the convertible top is raised about two-thirds of the way, however, raising action will stop as a safety check. At this time, release the switch and after making sure operation is safe and normal, you may rotate the switch forward (away from you) once again to complete raising operation.

10. Retract both top lock levers to LOCK position, then close the top lock lids.

CAUTION

Be careful not to catch your hand in the top lock lever.

NOTE

From inside the vehicle, make sure the top is securely locked by the top lock levers by pushing up on the top. If the top is locked by the levers, but nevertheless sounds loose (rattles), have it inspected at your nearest Authorized Mazda Dealer.

NOTE

Even if you rotate the convertible top control switch, the convertible top cannot be raised (or lowered) when the parking brake is not set (the warning sound will be heard). (See page 3-53, convertible top warning beeper)

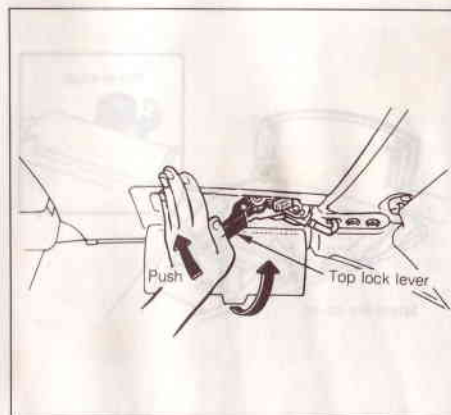
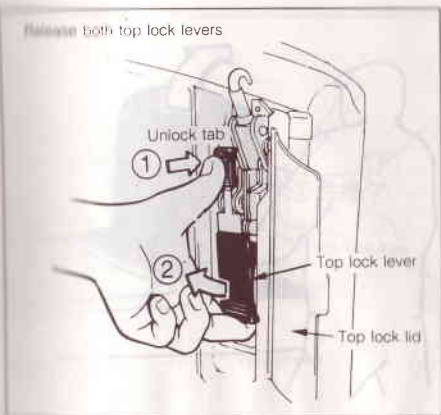

IF THE TOP CANNOT BE RAISED USING THE SWITCH

1. Slide both seats fully forward. Then turn the panel knobs and lift up the spare tire cover.

2. Insert a Phillips screwdriver into the left and right service holes, and turn it clockwise until it can no longer turn.

3. Raise the convertible top by hand.

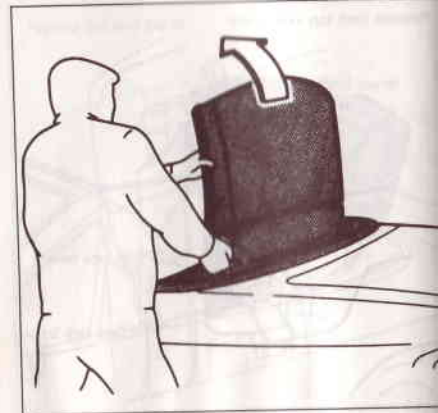
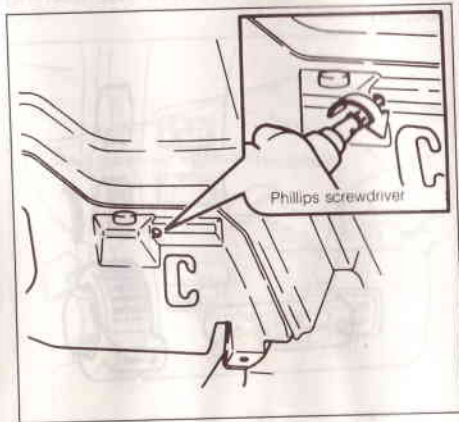
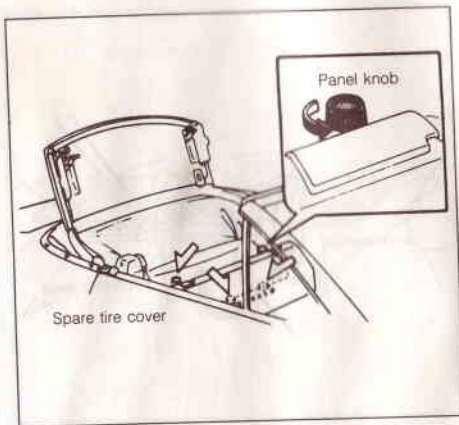

4. **Secure** the convertible top using the top lock levers, then close the top lock lids.

NOTE

From inside the vehicle, make sure the top is securely locked by the top lock levers by pushing up on the top.

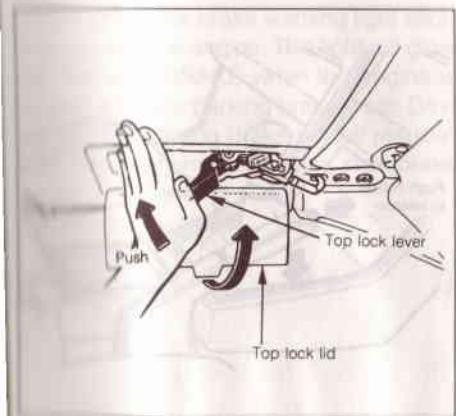

5. After performing the above, have your vehicle inspected by an Authorized Mazda Dealer as soon as possible.

CAUTION

This procedure should be followed only in the event of a malfunction, when the top cannot be raised with the switch, and not at any other time.

FLOOR CONTROLS

BRAKE PEDAL

If the brake pedal should fail to operate while the vehicle is in motion, you can make an emergency stop with the parking brake. The stopping distance, however, will be much greater than normal.

ANTI-LOCK BRAKE SYSTEM (Except cabriolet models)

When the anti-lock brake system is in operation, a vibration will be felt in the steering wheel, the vehicle body, and the brake pedal, but this just serves to indicate that the mechanism is working properly — it in no way means that there is a malfunction in the system.

When starting the engine from a fully stopped condition, and when the vehicle advances until it is around the 6 km/h (3.7 mph) speed range, noise from the motor will be heard in the engine compartment, but this sound serves to indicate that the vehicle is checking the function of the equipped anti-lock brake system, and in no way means that there is a malfunction in the system.

NOTE

Operation of the brake system warning light is covered in Section 3 under Instruments and Controls.

WARNING!

- Do not drive with your foot resting on the brake pedal. This will result in abnormally high brake temperatures, excessive lining wear and increased stopping distances.
- When descending a long or steep hill, shift to a lower gear and avoid continuous use of the brakes. Continuous use will cause the brakes to overheat, resulting in a temporary loss of braking performance.
- Driving through water deep enough to wet the brakes may adversely affect brake performance. The vehicle may not slow down at the usual rate and may pull to the right or left when brakes are applied. Applying the brakes lightly will indicate whether they have been affected in this way. To dry the brakes, apply them lightly while maintaining a safe forward speed until brake performance returns to normal.

97E3-0780E

PARKING BRAKE

The parking brake control is located between the front seats. To set the parking brake, apply the foot service brake while pulling the parking brake handle fully and firmly up.

WARNING!

- Do not use the gearshift selector in place of the parking brake. Always set the parking brake fully and make sure the gearshift selector is securely latched in (First).

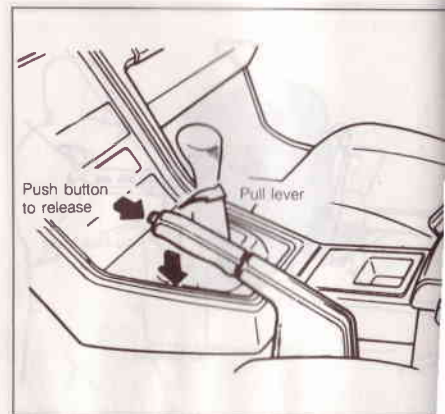

97U3.0640E

POWER BRAKES

- Turn off the ignition when you leave the vehicle, even momentarily. Never leave the vehicle unattended while the engine is running.
- Unexpected and possibly sudden vehicle movement may occur if these precautions are not taken.
- If the parking brake is released and the BRAKE light remains on, this is an indication of a malfunction in the brake system. Immediate attention is necessary.

To release the parking brake, pull handle upward and push the button. Then lower the handle to the released position while holding the button in.

Always check the brake warning light each time you start the engine. This light will glow with the word BRAKE when the engine is running and your parking brake is set. Driving with the parking brake set will result in poor fuel economy and rapid rear brake wear.

In the event power assist is lost because of a stalled engine or other reason, you can still stop your vehicle by applying greater force to the brake pedal than you normally would with the power assist. The stopping distance, however, will be longer.

When the engine is not running, the reserve brake power is partially depleted each time the brake pedal is applied and released. Do not pump the brake pedal when the power assist has been interrupted, except when necessary to maintain steering control.

97U3.0650E

BRAKE PAD WEAR INDICATOR (only for front disc brake pads)

When the brake pad becomes very thin, the metal in the brake pad will contact the disc plates, causing a screeching noise to warn the driver that the brake pad should be replaced.

WARNING!

Failure to replace the brake pads may result in damage to the brake system and adversely affect brake performance.

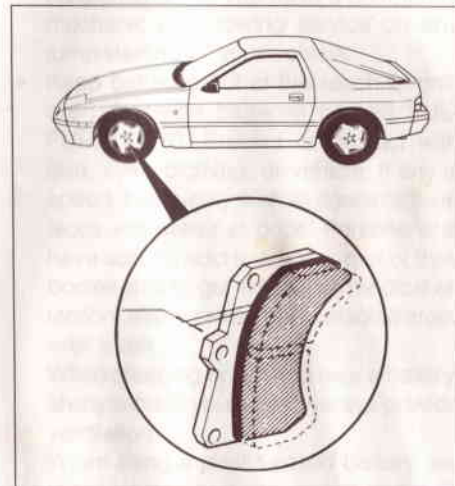

BRAKEPAD WEAR INDICATOR (only for front disc brake pads)

When the disc brake pads wear, they will make a noise. This noise is a warning that the brake pads are worn and need to be replaced. The noise is a high-pitched squeal that is most noticeable when you apply the brakes.

WARNING: Do not attempt to adjust the brake pads. The brake pads are designed to wear and should be replaced when they are worn. Adjusting the brake pads can cause damage to the brake system and reduce the effectiveness of the brakes.



The wear indicator is a small metal tab that is attached to the surface of the brake pad. As the brake pad wears, the tab will eventually reach the brake disc, which will cause a noise. This noise is a warning that the brake pads are worn and need to be replaced.

POWER BRAKES

In the event of a power brake failure, the driver should apply the brakes as normally as possible. The driver should also pump the brake pedal to build up hydraulic pressure. The driver should also use the parking brake if necessary. The driver should also use the emergency brake if necessary.

WARNING: Do not attempt to adjust the power brake system. The power brake system is a complex system and should only be adjusted by a qualified technician. Adjusting the power brake system can cause damage to the brake system and reduce the effectiveness of the brakes.

The power brake system is a complex system that uses hydraulic pressure to apply the brakes. The driver should apply the brakes as normally as possible. The driver should also pump the brake pedal to build up hydraulic pressure. The driver should also use the parking brake if necessary. The driver should also use the emergency brake if necessary.

The power brake system is a complex system that uses hydraulic pressure to apply the brakes. The driver should apply the brakes as normally as possible. The driver should also pump the brake pedal to build up hydraulic pressure. The driver should also use the parking brake if necessary. The driver should also use the emergency brake if necessary.

The power brake system is a complex system that uses hydraulic pressure to apply the brakes. The driver should apply the brakes as normally as possible. The driver should also pump the brake pedal to build up hydraulic pressure. The driver should also use the parking brake if necessary. The driver should also use the emergency brake if necessary.

Turn off the ignition when you leave the vehicle, even momentarily. Never leave the vehicle unattended with the engine running.

Check the brake fluid level regularly. The brake fluid level should be checked at least once a month. The brake fluid level should be checked when the engine is running. The brake fluid level should be checked when the engine is running.

WARNING: Do not attempt to adjust the brake fluid level. The brake fluid level is a critical part of the brake system and should only be adjusted by a qualified technician. Adjusting the brake fluid level can cause damage to the brake system and reduce the effectiveness of the brakes.

The brake fluid level is a critical part of the brake system. The driver should check the brake fluid level regularly. The driver should check the brake fluid level when the engine is running. The driver should check the brake fluid level when the engine is running.

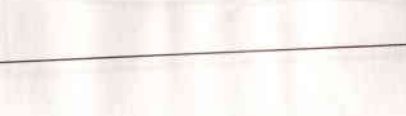

The wear indicator is a small metal tab that is attached to the surface of the brake pedal. As the brake pedal wears, the tab will eventually reach the brake disc, which will cause a noise. This noise is a warning that the brake pads are worn and need to be replaced.

4. SPECIAL AND EMERGENCY OPERATING CONDITIONS

97U4.0010E

HAZARD WARNING FLASHER

Use the hazard warning flasher to warn other drivers anytime your vehicle becomes a traffic hazard, whether day or night. It should be used whenever emergency repairs are being made or when your vehicle is stopped near the edge of a roadway. Depress the flasher switch, with the ignition switch on or off, and all turn signal lights will flash simultaneously.

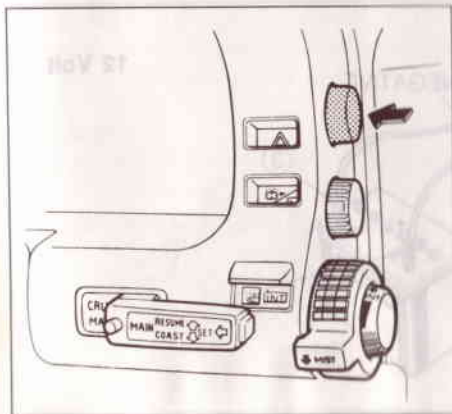

NOTE

Care must be taken when using the hazard warning flasher while the vehicle is being towed on a road or highway. Local regulations may prohibit using the hazard warning flasher in this manner.

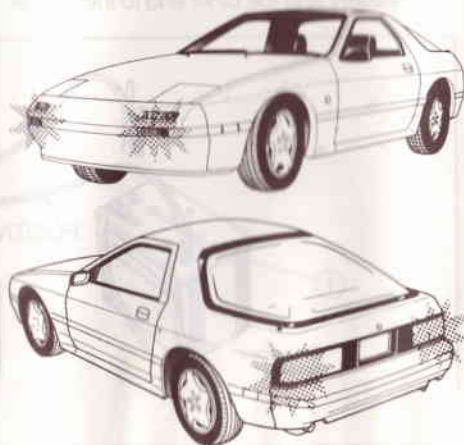

97U4.0020E

EMERGENCY STARTING

JUMP-STARTING WITH AUXILIARY BATTERY

WARNING!

- Jump-starting can be dangerous if done incorrectly. Therefore, if the following conditions cannot be met, or if you are uncertain about them, we strongly recommend that you have a competent mechanic or a towing service do any jump-starting of your vehicle.
 - Keep batteries out of the reach of children, because batteries contain SULFURIC ACID. Prevent its contact with skin, eyes, clothing, or vehicle. If any is spilled, thoroughly flush all contacted surfaces with water at once. Persons who have sulfuric acid touch any part of their bodies should get immediate medical attention, after washing the contacted areas with water.
- When charging or working near a battery, always shield your eyes. Always provide ventilation.
- When lifting a plastic-cased battery, excessive pressure on the end walls could cause acid to spew through the vent

caps, resulting in personal injury. Lift with a battery carrier or with your hands on opposite corners.

- Keep all flames away from the top of open battery cells, and avoid creating any sparks near the cells. Gas that can be exploded by a flame or spark is produced during normal battery operation.
- Do not attempt a jump-start if the discharged battery is frozen or the fluid level is low; the battery may rupture or explode.
- Do not use 24-volt power (e.g., two 12-volt batteries in series or a 24-volt motor generator set); this will damage the electrical components.
- To avoid harm to yourself or damage to your vehicle or battery, follow these directions carefully. If in doubt, call for road service.

To jump-start, follow these steps.

1. Make sure the booster battery is 12-volt and that its negative terminal is grounded.
2. If the booster battery is installed in another vehicle, do not allow the vehicles to touch.
3. Turn off all unnecessary electrical loads.
4. Connect the jumper cables in the exact sequence as in the illustration. First connect one end of a jumper cable to the positive terminal of the discharged battery and the other end to the positive terminal on the booster battery. Next connect one end of the other jumper cable to the negative terminal of the booster battery and the other end to the engine

- being started (NOT TO NEGATIVE (-) TERMINAL OF BATTERY), taking care that the clamps from one cable do not inadvertently touch the clamps on the other cable or any metal on either vehicle. Do not lean over the battery when making connections.
5. Start the engine of the vehicle with the booster battery, and let it run a few minutes. Then start the engine of the vehicle with the discharged battery.
6. Carefully disconnect the cables in the exact reverse order described in step 4.

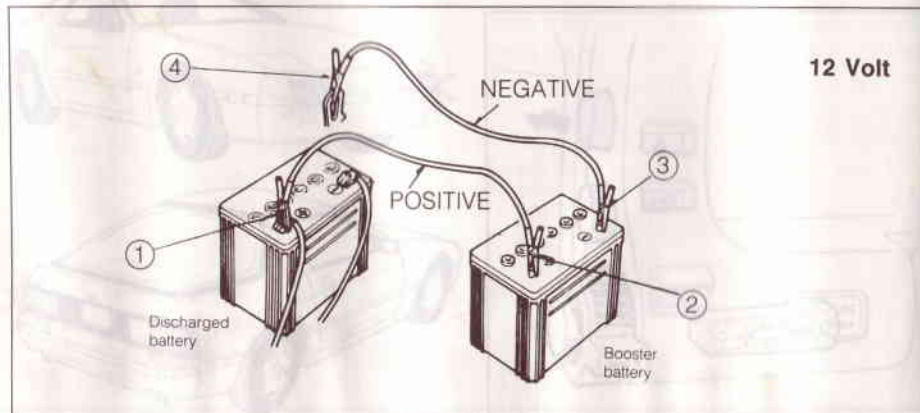

PUSH STARTING

Do not attempt to start a vehicle by pushing, as this may result in damage to the vehicle's emission control system.

CAUTION

Never tow a vehicle to start it because the sudden surge forward when the engine starts could cause a collision with the tow vehicle.

TOWING

Proper lifting or towing procedures are necessary to prevent damage to the vehicle during any towing operation. Government laws applicable to vehicles in tow must be followed.

If towing is necessary, we recommend you have it done by your Mazda Dealer or a commercial tow truck service.

If the transmission, rear axle and steering system are not damaged, the vehicle may be towed on all four wheels. If these components are damaged, use a towing dolly.

If towing speed will exceed 45 km/h (30 mph), or if the towing distance will exceed 15 km (10 miles), use one of three methods:

1. Place the rear wheels on a dolly.
2. Tow with the rear wheels off the ground.
3. Disconnect the propeller shaft.

If the transmission or rear axle are inoperative, tow with the rear wheels off the ground, or have the propeller shaft disconnected.

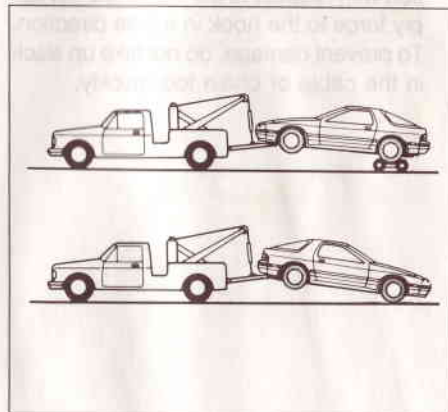

CAUTION

- The following points are important when the vehicle is towed with all 4 wheels on the ground. The shift lever must be set at NEUTRAL, the ignition key in the ACC position, and the parking brake released. Remember that the power assist for the brakes and steering (if equipped) will not be available when the engine is inoperative.
- The towing hook should be used only in an emergency situation, (e.g., to pull the vehicle out of a ditch, a snow bank or mud).
- When the towing hook is used, always pull the cable or chain in a straight direction with respect to the hook. Do not apply force to the hook in a side direction. To prevent damage, do not take up slack in the cable or chain too quickly.

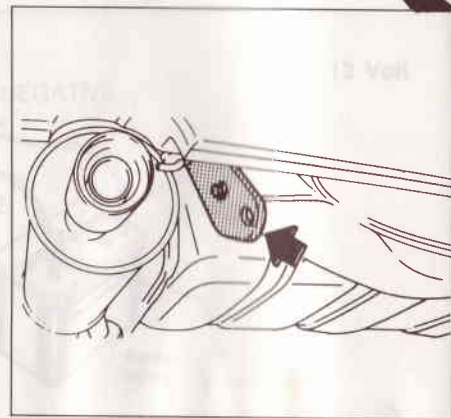
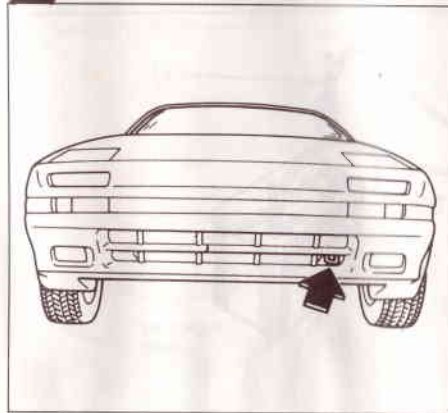
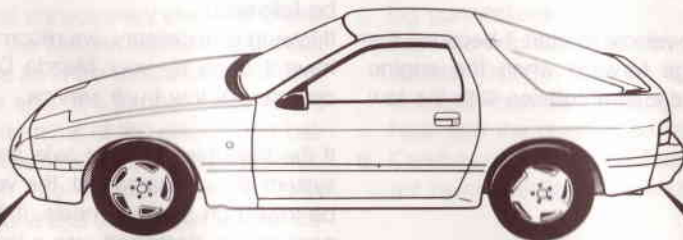

HAZARDOUS DRIVING CONDITIONS

When hazardous driving is encountered because of water, snow, ice, mud, or sand, follow these suggestions.

- Drive cautiously and allow extra distance for braking.
- Avoid sudden movements in braking or steering.
- When braking, depress the brake pedal with a light up-and-down motion until the vehicle is stopped.
- If stuck in snow, mud, or sand, use second gear and accelerate slowly. Low gear may be used, if necessary. Move slowly to avoid spinning the rear wheels.
- Use sand, rock salt, tire chains, or carpeting under the rear wheels to provide traction when stuck in ice, snow, or mud.

WARNING!

On slippery surfaces, do not downshift into FIRST.

This may cause skidding.

ROCKING THE VEHICLE

If it is necessary to rock the vehicle to free it from snow, sand or mud, move the shift lever from first to reverse gear, while depressing the accelerator gently. Do not race the engine. If you are still stuck after a minute or two of rocking, have the vehicle pulled out to avoid overheating and possible damage to the transmission.

CAUTION

Prolonged rocking, may cause engine overheating, transmission damage or failure, or tire damage.

SPARE TIRE, WHEEL LUG WRENCH AND WHEEL STOPPERS, JACK AND JACK HANDLE

(Except cabriolet models)

The spare tire, tools, jack and jack handle are stowed in the luggage room.

NOTE

To eliminate the possibility of the jack, jack handle or tools rattling while the vehicle is moving, stow them properly.

(for vehicles equipped with temporary spare tire)



(for vehicles equipped with standard size spare tire)



To remove spare tire:

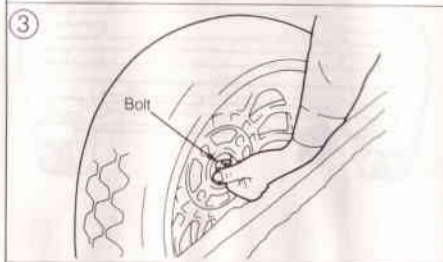
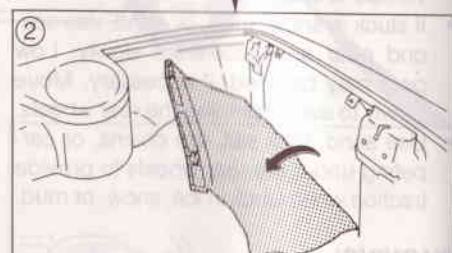
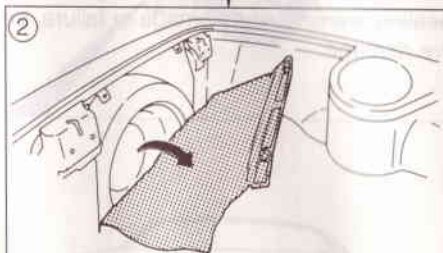
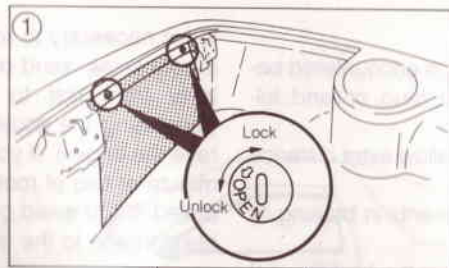

(Cabriolet models)

The spare tire is stored under the spare tire cover.

The tool bag, jack and jack handle are stored in the trunk.

Temporary spare tire (if equipped)
The temporary spare tire is intended for use only in an emergency situation and should not be used for extended periods. It is not designed for high speeds and should not be used for extended periods. The temporary spare tire may not be used on roads with steep grades, rough roads, or potholes. It is not designed for use on roads with steep grades, rough roads, or potholes. It is not designed for use on roads with steep grades, rough roads, or potholes.

Do not go through an automatic car wash with this tire inflated.



To remove spare tire

1. Slide both seats fully forward. Then turn the panel knobs and remove the spare tire cover.

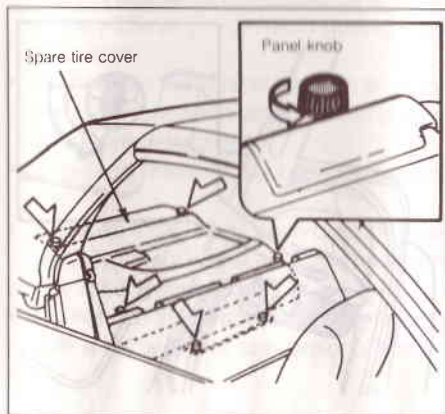

2. Turn the wing bolt counterclockwise by hand.

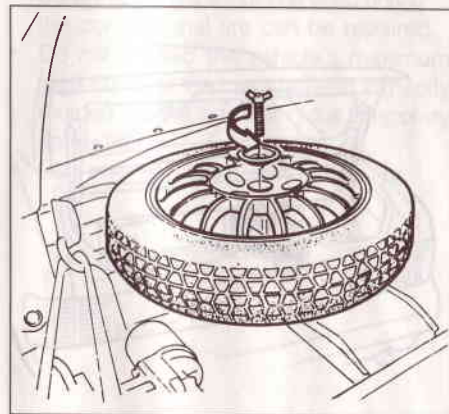

To remove toolbag

1. Pull back the cover.
2. Remove the toolbag.

NOTE

Store the toolbag in its original place after use.

To remove jack and jack handle:

1. Peel back carpet in left rear end of trunk room.
2. Turn plastic fasteners to unlock access panel over jack.
3. Remove access panel to expose jack.

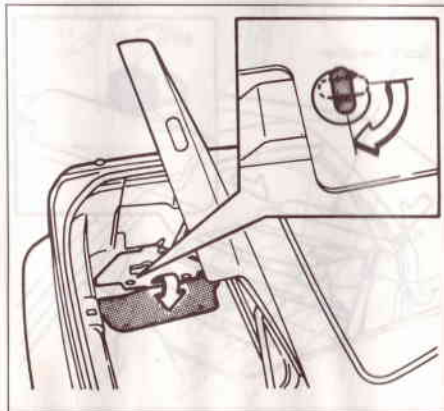
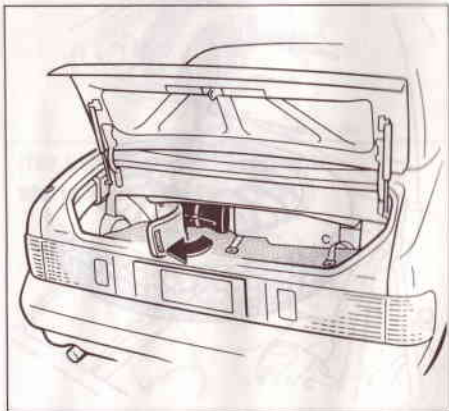

SPARE TIRE

Check the spare tire at least once a month to ensure that it is stowed securely and properly inflated.

97E4 0100E

Temporary spare tire (if equipped)

The temporary spare tire is easier to handle, due to its construction. It is lighter and smaller than a conventional tire, and is to be used only for emergency situations and for limited miles. Use the temporary spare tire only until the conventional tire is repaired. Check the temporary spare tire inflation pressure at least once a month and maintain at 415 kPa (4.2 km/cm², 60 psi).

When using the temporary spare tire, the following precautions must be observed:

- Use for limited mileage, temporary emergency use only.
This tire is identified by the distinctive wording **TEMPORARY USE ONLY** molded into the sidewall. Any continuous road use of this tire could result in tire failure, loss of vehicle control and possible personal injury.
- Do not exceed 80 km/h (50 mph) under any circumstances. It is recommended that your vehicle be driven at slow speeds to prevent damage to the tire.
- Because the spare tire's diameter is smaller than the conventional tire, the ground clearance is reduced by approximately 25mm (1 in). Avoid driving over obstacles.
- Do not take the vehicle through an automatic vehicle wash while the temporary spare tire is installed.
- Avoid road hazards, such as chuck holes etc.
- Because this tire has been designed especially for your vehicle, do not use it on any other vehicle.
- Do not use the temporary spare tire rim with a snow tire or conventional tire.

- Do not use wheel covers, wheel rings or center caps with the temporary spare tire wheel.
- Do not use tire chains with this tire. Because of the smaller tire size, a tire chain will not fit properly. This could cause damage to the vehicle and result in loss of the chain.
- The temporary spare tire has a tread life of up to 4,800km (3,000 miles), depending on road conditions and your driving habits.
When the tread wear solid band indicator appears across the tread, replace it with the same type temporary spare tire. To conserve the tire's tread life, the temporary spare tire should be used only until the conventional tire can be repaired.
- Do not exceed the vehicle's maximum load rating or the load-carrying capacity molded into the side wall of the temporary spare tire.
- Use only one temporary spare tire.

Do not go through an automatic car wash with this tire installed

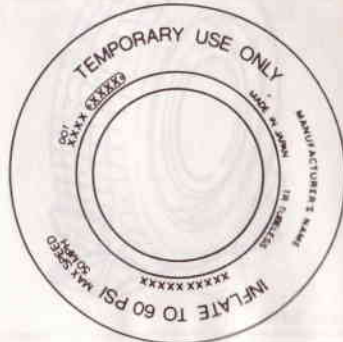

When inflating the temporary spare tire, use extreme caution as it will inflate much faster than the normal tire. Add compressed air in small quantities, and check the pressure frequently, until it reaches 415 kPa (4.2 kg/cm², 60 psi).

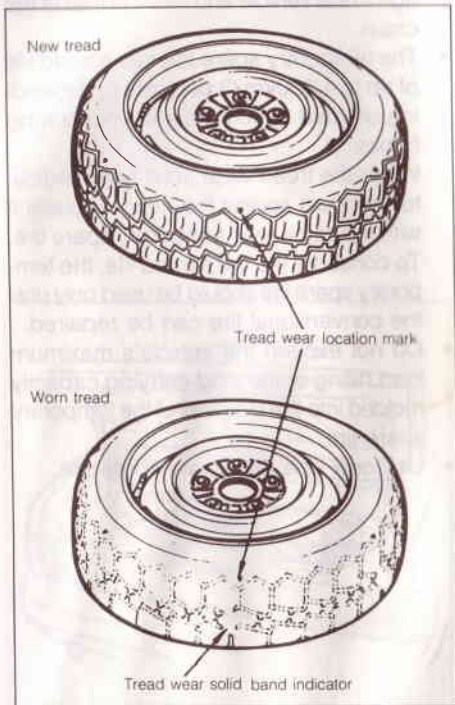

97C4 0080E

JACKING INSTRUCTIONS AND CHANGING A TIRE

WARNING!

- Be sure to use the correct front and rear jacking points on the vehicle, never use the bumpers or any other part of the vehicle for jack support.
- Do not exceed the jack's maximum permissible load, which is 650 kg (1,430 lbs) for aluminum jack, and 1,000 kg (2,200 lbs) for steel jack.
- The jack is provided for emergency wheel and tire changing only.
- Never get beneath the vehicle while using the jack.
- Do not start or run the engine while the vehicle is on the jack.
- Never attempt vehicle repairs in the traffic lanes of a public road or highway. Always move the vehicle completely off the road and onto the shoulder before trying to change a tire. If you cannot find a firm, level place off the road, call a service truck.
- Follow jacking instructions to reduce the possibility of personal injury.

97E4.0110E

Preparation:

- Park on a level surface and set the parking brake firmly.
- Shift the transmission into R (Reverse).

WARNING!

When one rear wheel is lifted off the ground, the transmission 1 (First) position will not prevent the vehicle from moving and possibly slipping off the jack, even if that position is properly engaged. To prevent inadvertent vehicle movement while changing a tire, always set the parking brake fully and always block the wheel diagonally opposite the wheel being changed.

- Activate the hazard warning flasher.

Procedures:

1. Remove the jack, jack handle and spare wheel from the vehicle.
To remove the spare tire, remove the lock bolt. (See page 4-6 for detailed information.)
2. Place the wheel stoppers at the front and rear of the wheel that is diagonally opposite the jacking point to be used.

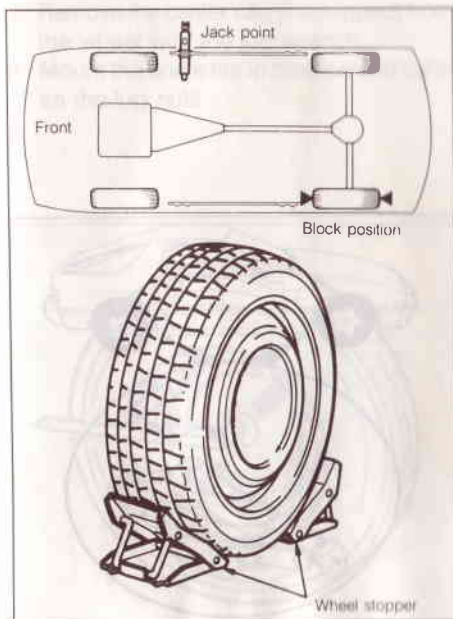

3. (Except cabriolet models)

Remove the center cap (if equipped) by evenly moving the tip of a screwdriver or the flat end of a lug wrench completely around its edge.

CAUTION

Do not use any tools besides a screwdriver or a lug wrench to remove the center cap. If you use any tools other than the above mentioned ones, you can cause damage to the tire or center cap.

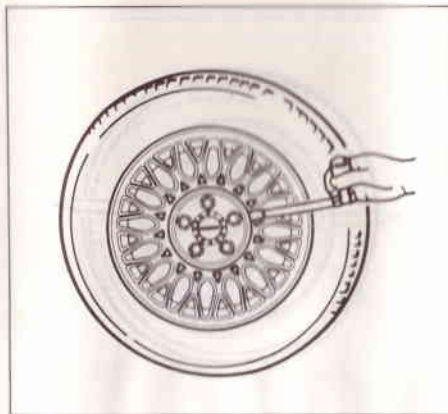

(Cabriolet models)

Remove the center cap.

- Fit the center cap wrench onto the center cap.
- Turn the wrench counterclockwise by hand while pressing down on the center cap with the palm of your other hand.

NOTE

The center cap wrench should be kept in the glove box.

CAUTION

The center cap wrench is made out of plastic. When removing the center cap, you should press down on it with the palm of your hand to keep it from falling and getting damaged. The center cap may also be damaged if you turn the wrench with your foot. When removing the center cap, therefore, you should only turn the wrench by hand.

NOTE

To install the center cap

Slip the center cap into the wheel's center hole. While pressing down on the center cap with the palm of your hand, turn the wrench clockwise by hand until the center cap touches the stopper.

Special wheel for convertible only

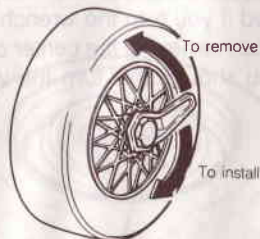
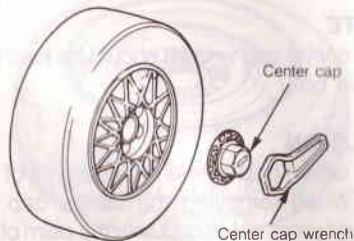

Turn the wrench by hand while pressing down on the center cap with the palm of your other hand.

4. Loosen the lug nuts one turn each, but do not remove any nut until the tire has been raised off the ground.

5. Place the jack at the front or rear jacking position closest to the tire you are changing. Place the jack under the jacking point on the side sill, as in the illustration.

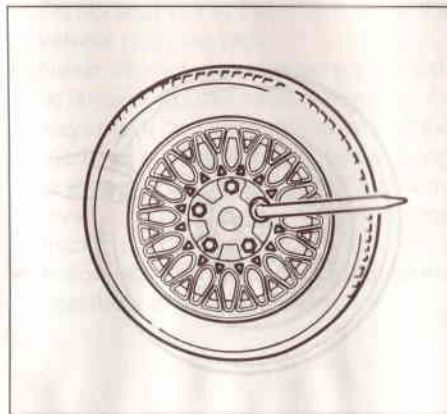

6. Insert the jack handle into the jack and turn it clockwise until the tire just clears the ground, about 30mm (1.2 in). Before removing the lug nuts, make sure the vehicle is stable and there is no chance for it to slip or move.
7. Remove the lug nuts by turning them counterclockwise and then remove the wheel.
8. Remove the center cap (if equipped) from the wheel with the lug wrench.
9. Mount the spare tire in position and tighten the lug nuts.



10. Turn the jack handle and lower the vehicle to the ground. Tighten the lug nuts in order, as illustrated.

If you are unsure of the tightness of the lug nuts, have them checked at the nearest service station or an Authorized Mazda Dealer. The specified tightening torque is 90 N·m to 120 N·m (9.0 to 12.0 m·kg, 65 to 87 ft·lb).

11. Reinstall the center cap.

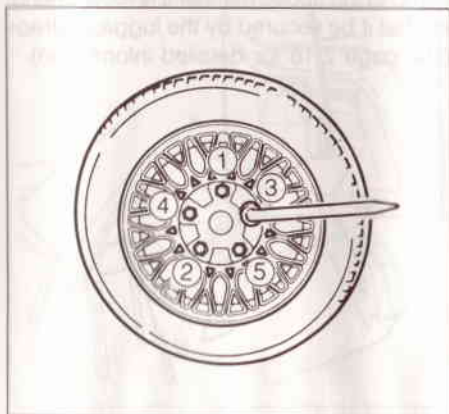

12. Store the jack and jack handle.

NOTE

To prevent of the jack and jack handle rattling while the vehicle is moving, stow them properly.

* Except cabriolet models

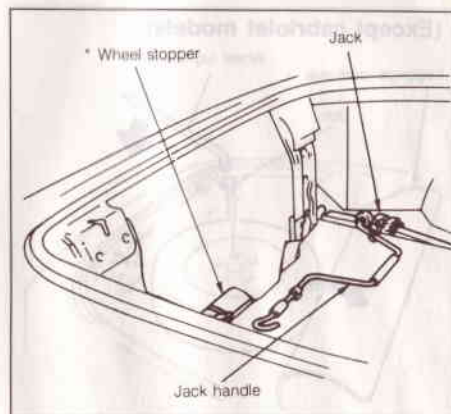

13. Store the removed tire as illustrated.
(Except cabriolet models)
1. Fold the luggage room mat forward.
 2. Mount the removed tire in the wheel space, face up, and insert the bolt provided in the tool envelope.
 3. Tighten the bolt with the wheel lug wrench.

(Except cabriolet models)

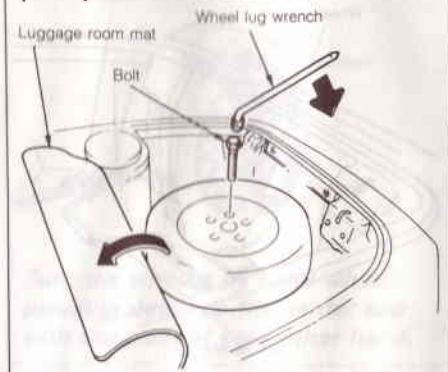

CAUTION
(For European models)

Your RX-7 is designed to carry a temporary compact, spare wheel and tire. This spare requires less storage space than a conventional wheel and tire. Therefore, a conventional wheel and tire cannot be stored in the same position as the temporary spare. Be sure to follow the special instructions listed here whenever it becomes necessary to store a conventional wheel and tire in your vehicle.

NOTE

If using the tire/wheel combination other than the original equipment and it cannot be secured in the above manner it is recommended that it be secured by the luggage straps (see page 2-16 for detailed information).



(Cabriolet models)

1. Slide the seats fully forward and be sure the top is in raised position.
2. Loosen the panel knob and remove the spare tire cover.

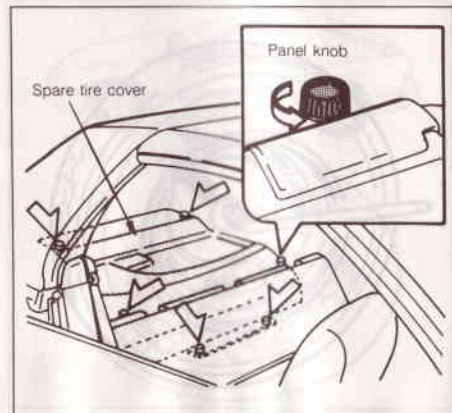

3. When storing a conventional tire, use the special wing bolt found inside the tool bag to hold it in place.



4. Close the spare tire cover over the tire and hold it in place with the straps.

CAUTION

- Do not fold the cabriolet down when a conventional tire is stored, because the spare tire cover cannot be firmly secured.
- A flat conventional tire should be repaired as soon as possible, and the temporary spare tire should be put back in its original storage space.

Storing conventional wheel and tire for cabriolet models only

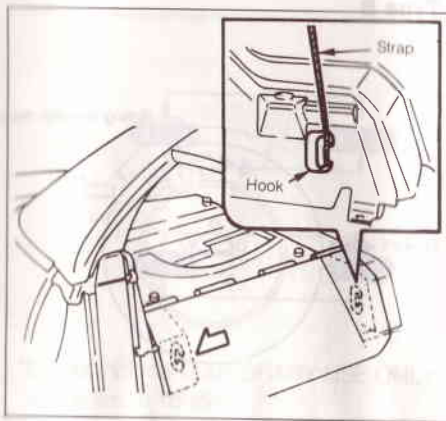

WARNING! WHEELS AND TIRES

To minimize the risk of personal injury during a sudden stop or collision, make sure the tire is installed and secured properly.

CAUTION

CAUTION: Do not fold the cabriolet down when a conventional tire is stored, because the spare tire cover cannot be firmly secured. A flat conventional tire should be repaired as soon as possible, and the temporary spare tire should be put back in its original storage space.

WHEELS AND TIRES

USE OF DIRECTIONAL TIRES

The direction of tire rotation is decided according to the tread pattern, which affects the tire's performance in wet conditions.

The directional tires must be installed according to the rolling direction marks. These marks are molded into the side wall of the tires as illustrated.

CAUTION

Directional tires cannot be rotated from the right side of the vehicle to the left. If they are rotated from right to left, tire performance may be reduced in wet conditions.

For correct tire rotation of directional tires, refer to TIRE ROTATION on page 4-17.

Example of rolling direction marks for directional tire.

Type A

(Left side)

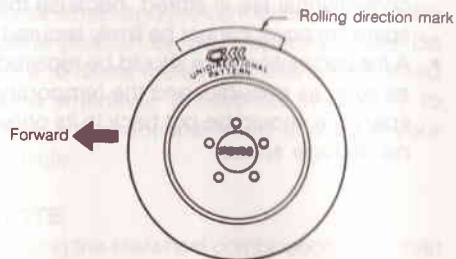

(Right side)

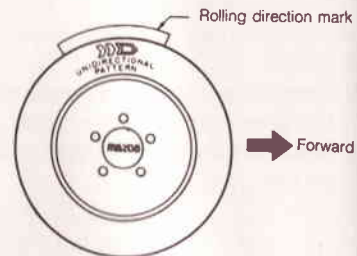

Type B

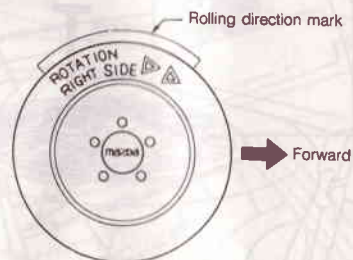
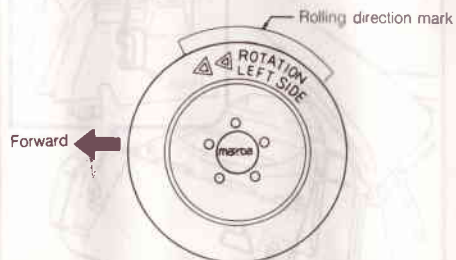

USE OF SNOW TIRES

When snow tires are used, select the same size and construction as indicated in the tire pressure chart label. It is strongly recommended that snow tires be used on all four wheels, or poor handling may result. Snow tires should not be operated at speeds over 120 km/h (75 mph). These tires should be inflated 28 kPa (0.3 kg/cm², 4 psi) above the recommended pressures shown on the tire pressure chart, but never exceed the maximum cold tire pressure shown on the tire sidewall.

CAUTION

Do not install studded tires without first checking local regulations for possible restrictions.

TIRE CARE

Careful inspection is recommended at every oil change and before long trips. Check for cuts, bruises, sharp objects imbedded in the tread and proper inflation pressures.

TIRE ROTATION

To equalize tread wear, it is recommended that the tires be rotated every 6,000 km (3,750 miles) (or sooner if irregular wear develops), as indicated in the diagram below and, at the same time, checked for correct balance.

Upon rotation, the inflation pressures must be adjusted in accordance with the recommendations on the cold tire inflation pressure chart.

NOTE

It is recommended that disc brake pads be inspected for wear whenever tires are rotated.

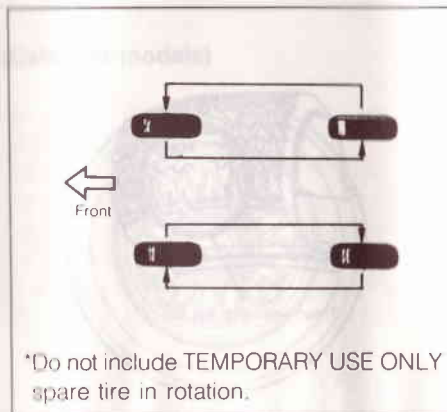

CAUTION

- Do not rotate the tires according to the pattern shown in figure if the front and rear tires are of different sizes.
- Do not rotate radial tires with an asymmetric tread pattern or spikes from left to right, only from front to back.
- Do not rotate directional tires, right to left, but only front to rear.

TIRE USAGE

When replacing tires, only the same size and construction type originally installed on your vehicle are recommended by Mazda. Use of any other tire size or type may seriously affect ride, handling, ground clearance, tire clearance and speedometer calibration.

This warning does not apply to a temporary spare tire furnished with your vehicle.

CAUTION

- Bias and bias belted tires should not be used together on the same vehicle.
- Radial tires should not be used together with other type tires on the same vehicle.
- New tires should be installed in pairs on the same axle (left and right).

TIRE WEAR

Built-in tread wear indicator bars appear on each tire when the tread depth reaches 1.6mm (0.06 in).

These bars appear as a solid band across the tread. A tire should be replaced when the bars appear.

**REPLACEMENT WHEELS**

When replacing wheels for any reason, care should be taken to insure that the wheels are equivalent to original factory units, in diameter, rim width and offset.

When a tire or wheel is replaced, the wheel should always be balanced.

CAUTION

A wrong size wheel may adversely affect wheel and bearing life, braking and stopping ability, handling characteristics, ground clearance, body-to-tire clearance, snow chain clearance, speedometer calibration, headlight aim and bumper height.

USE OF ALUMINUM WHEEL**(if equipped)**

The original equipment 15" and 16" aluminum wheels are directional and must be used in the correct positions (right and left). When replacing the tires make sure that the wheels are mounted to the original right or left position.

NOTE

RH (Right hand) or LH (Left hand) are stamped on the wheel.

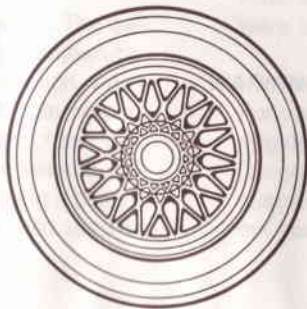
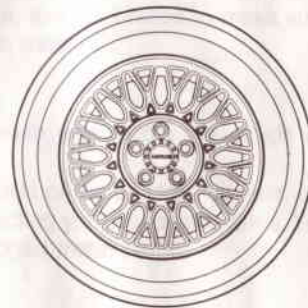
15-INCH WHEEL**(Cabriolet models)****16-INCH WHEEL**

TIRE USAGE

When a tire is used on a road surface that is not designed for that use, the tire may be damaged. The tire may also be damaged if it is used on a road surface that is not designed for that use. The tire may also be damaged if it is used on a road surface that is not designed for that use.

Do not use a tire on a road surface that is not designed for that use. Do not use a tire on a road surface that is not designed for that use.

CAUTION

Do not use a tire on a road surface that is not designed for that use. Do not use a tire on a road surface that is not designed for that use.

TIRE YEAR

Do not use a tire on a road surface that is not designed for that use. Do not use a tire on a road surface that is not designed for that use.

REPLACEMENT OF ALUMINUM WHEELS

When replacing a tire on a vehicle with aluminum wheels, the tire must be replaced with a tire that is designed for use on aluminum wheels. Do not use a tire that is not designed for use on aluminum wheels.

CAUTION

Do not use a tire on a road surface that is not designed for that use. Do not use a tire on a road surface that is not designed for that use.

18-INCH WHEEL (See also page 18)



(Certain models)



18-INCH WHEEL



5. APPEARANCE CARE

76G5.0010E

NOTE

It is very important to always follow label directions when using any chemical cleaner or polish. Read all warning and caution statements which appear on the label.

1. FINISH MAINTENANCE

1. Damage to the vehicles finish can be caused by small deposits of dirt, insects, tree sap, chemicals and bird droppings. Prompt removal of these deposits will preserve the vehicles finish. A mild car wash soap should be used; avoid using strong soaps or chemical detergents.
2. Wash your Mazda by hand, using plenty of water and a mild car wash soap. When using an automatic car wash, choose one without excessive brush pressure, and an ample supply of rinse water.
3. Wash away the detergent using plenty of clean water. The water used for washing and rinsing should be cold or lukewarm.
4. To help protect your vehicle from rust and deterioration, wash it thoroughly and frequently (at least once a month), paying particular attention to the removal of any accumulation of salt, dirt, mud, or other materials, from the underside of the fenders. Remove these completely from the underbody by using a stream of water. If the mud is difficult to remove, use a mild soap or a car-washing detergent.

5. After soaping, rinse the vehicle thoroughly with lukewarm or cold water. Do not allow the soap to dry on the finish. In addition, the painted and bright metal exterior surfaces of your vehicle should be coated with a good quality wax.

CAUTION

- Do not wash or wax in direct sunlight.
- Washing the vehicle should be delayed if the body is hot. If not, water spots may form on the paint surface.
- Do not use hot water. It is best to use cool to lukewarm water to prevent damaging the paint.
- Wiping off dust or dirt with a dry cloth may scratch the finish.
- When cleaning plastic wheel covers, wash with plenty of water. Use a sponge, chamois, or soft cloth to prevent scratching or damaging the finished surface.
- Wipe the vehicle dry using a chamois to avoid water spots.
- After washing the vehicle, test the brakes to make sure they were not affected by the water.

WARNING!

- For your safety, do not wash, wax, or dry the vehicle with the engine running:
- Do not clean the underside of the chassis, fenders, or other such areas, without protecting your hands and arms. You may cut yourself on sharp-edged metal parts.

6. After washing, check whether drainholes of doors, side sills, rear fenders are clogged. If they are, clean them.

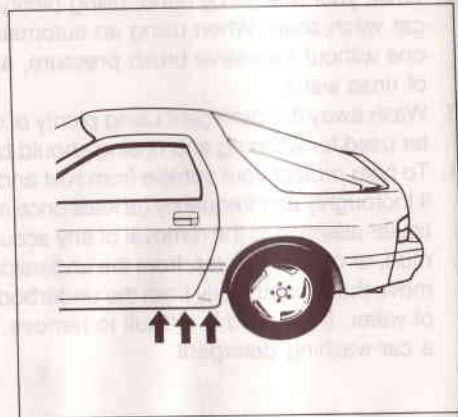
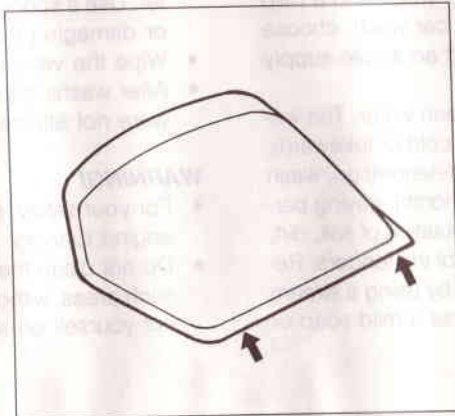
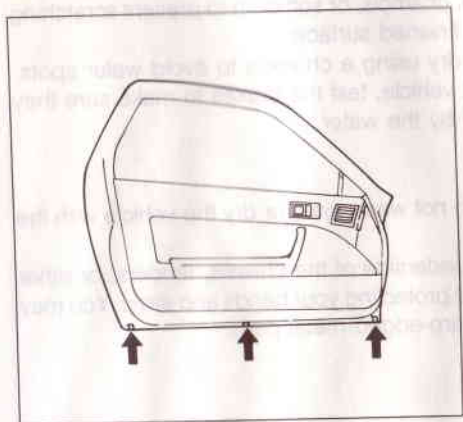

2. CLEANING THE INTERIOR AND FLOOR

Rust begins to form not only from the outside but also from the inside.

Water, humidity, salt, mud, etc. collect under the mat in the luggage compartment, so rust could begin from there.

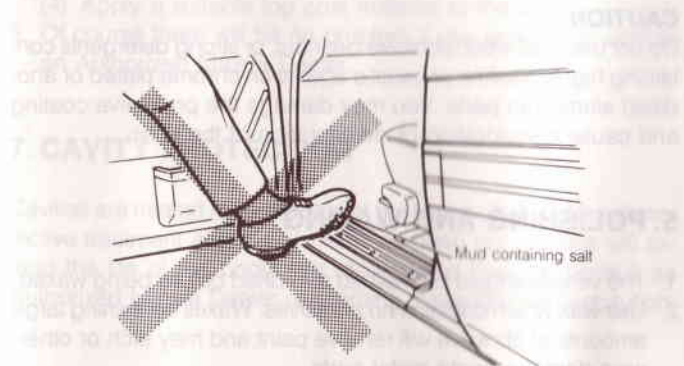

Periodically dry the floor after removing the accumulations of mud and deposits of salt which rapidly attach to metal.

If you place or carry de-icing salt, fertilisers, chemicals etc. in the luggage compartment or elsewhere, take every possible precaution to be sure that they do not adhere to the floor or fall onto the floor.



3. CARE OF ALUMINIUM WHEELS

Your aluminium wheels are coated with a clear protective finish.

CAUTION

- Do not use any abrasive cleaners, polishing compounds, solvents, or wire brushes. These may scratch or damage the finish. Use only a mild soap or neutral detergent and rinse thoroughly with water. Also, during winter, be sure to clean aluminium wheels after driving on salted roads. This helps prevent corrosion.
- Avoid washing the wheels with a high-speed washing machine.



4. CARE OF BRIGHT METAL PARTS

1. Use tar remover rather than knives or other sharp objects to remove road tar and insects.
2. To protect these surfaces from corrosion, apply a coating of wax or chrome preservative and rub to a high polish.
3. During winter weather or in coastal areas, cover the chromed parts with a heavier coat of the wax or preservative. Under severe conditions, coat the parts with non-corrosive petroleum jelly or some other protective compound.

CAUTION

Do not use steel wool, abrasive cleaners, or strong detergents containing highly alkaline or caustic agents on chrome plated or anodised aluminium parts. You may damage the protective coating and cause discoloration or deterioration of the finish.

5. POLISHING AND WAXING

1. The vehicle should be washed and dried before being waxed.
2. Use wax which contains no abrasives. Waxes containing large amounts of abrasive will remove paint and may etch or otherwise damage bright metal parts.
3. Use a good grade of carnauba wax for metallic, mica and solid dark colors.
4. When waxing, coat evenly with the supplied sponge or a soft cloth.
5. Wipe the vehicle using soft cloth such as flannel.

6. PAINT DAMAGE TOUCH-UP

1. Repair damage in coated film caused by stone chipping, damage during parking etc., by using Mazda touch-up paint immediately after removing the dirt and grease with a clean soft cloth and before rust begins to form.
2. If rust has already begun to form:
 - (1) Remove rust completely with sandpaper, etc.
 - (2) Wipe with a clean soft cloth.
 - (3) Apply rust preventive primer to the area. After drying it completely:
 - (4) Apply a suitable top coat material to the area.
3. Of course there will be no problem if you assign the work to an Authorized Mazda Dealer.

7. CAVITY PROTECTION

Cavities are treated for protection at the factory, but additional protective treatment after the vehicle has been put into use will extend the life of the body. We recommend that you consult an Authorized Mazda Dealer concerning this additional precaution.

8. UNDERCOATING

This special coating is applied to the critical parts of the underside to protect vehicles from damage caused by chemicals or stones. This coating is liable to be damaged as the vehicle is used. Consequently, check this coating periodically and, if damage is found, repair it.

In this connection, Mazda Dealers are well informed on how repairs should be made. We recommend that you consult with a Mazda Dealer.

9. GENERAL CAUTION

Prevent caustic solutions such as perfume, cosmetic oil, etc. from coming in contact with the dashboard and trim because these may cause damage or discoloration. If a solution of this type does come in contact, wipe it off immediately.

10. CARE AND MAINTENANCE OF THE CONVERTIBLE TOP

A special, high quality material is used for the convertible top, but when care of the top is improper or insufficient, hardening, staining and loss of luster may result. The top must be maintained according to the prescribed car and maintenance guidelines.

Washing the convertible top

Do not wait until it gets very dirty before cleaning it. Dirt that remains too long on the top can cause deterioration.

1. Gently clean the top with a mild soap, plenty of water and a soft brush.
2. Thoroughly rinse the top with clean water to remove all soap.
3. Wipe the top dry before the water dries on it.

CAUTION

- Automatic or high pressure car washes are harmful to the convertible top. Avoid using these to wash the vehicle.
- Do not direct water from the hose directly to the area where the window glass and the convertible top meet. Water will most likely get into the passenger compartment of the vehicle.

Appearance care

The convertible top may be dressed about once a month after it has been washed and dried well. For best results, use a water-based leather treatment or vinyl top dressing. Several brands of spray-on treatments for vinyl are widely available.

CAUTION

- Some brands of leather treatment on the market can ruin the gloss on the top's cover. You should be careful, therefore, to choose a wax that is appropriate.
- Be careful not to let any regular car wax get on the convertible top. If for any reason it should get on the top, remove it with leather cleaners.
- Too much treatment on your top can be as damaging as too little. Follow direction for the brand of treatment and don't over-do it!

6. MAINTENANCE

77E6.0010E

You should exercise the utmost care to prevent damage to your vehicle or yourself whenever using this manual for maintenance or inspection.

Should you have any doubts concerning inspections or servicing of your vehicle, we strongly recommend that you have a reliable and qualified service shop perform this work, preferably an Authorized Mazda Dealer. Inadequate, incomplete, or insufficient servicing may result in operational problems with your vehicle or even lead to vehicle damage, accident, and personal injury to yourself.

97E6.0015E

OWNER'S RESPONSIBILITY

Maintenance Services and Record Retention are the owner's responsibility.

You should retain evidence that proper maintenance has been performed on your vehicle in accordance with scheduled maintenance services chart starting on the following page.

Detailed warranty information is also provided with your Mazda vehicle.

Claims made during the warranty term will not qualify under any warranty if they result from lack of maintenance rather than from defective material or workmanship. We recommend that such maintenance be performed by an Authorized Mazda Dealer using genuine Mazda parts.

SCHEDULED MAINTENANCE SERVICES (For European models)

Maintenance Item	Maintenance Interval	Number of Months or Km (Miles), whichever comes first										
		Months* ¹		12		24		36		48		
		x1000	Km	1.0	10	20	30	40	50	60	70	80
			Miles	0.6	6	12	18	24	30	36	42	48

Engine

Drive belts* ²	A		A		A		A		A
Engine oil* ³	R	R	R	R	R	R	R	R	R
Oil filter* ³		R	R	R	R	R	R	R	R

Cooling system

Cooling system (including coolant level adjustment)			I		I		I		I
Engine coolant	Replace every 2 years								

Fuel system

Idle speed			A		A		A		A
Air cleaner element* ⁴			I		R		I		R
Fuel filter					R				R
Fuel lines and hoses			I		I		I		I
Initial ignition timing					I				I

Ignition system

Spark plugs	(Sweden)	Adjust every 30,000 km								
	(Except Sweden)			A		A		A		A

See footnote on page 6-5 for explanation of asterisk followed by number (e.g. *1) and letter codes used in this chart.

SCHEDULED MAINTENANCE SERVICES (cont'd)

Maintenance Item	Maintenance Interval	Number of Months or Km (Miles), whichever comes first									
		Months* ¹		12		24		36		48	
		x1000	Km	1.0	10	20	30	40	50	60	70
		Miles	0.6	6	12	18	24	30	36	42	48

Evaporative emission control system

Evaporative system (Unlead models)	(Sweden)	Inspect every 80,000 km									
	(Except Sweden)			A		A		A		A	

Exhaust emission control system

Dash pot	(Sweden)	Adjust every 80,000 km									
	(Except Sweden)			A		A		A		A	

Electrical system

Battery electrolyte level and specific gravity				A		A		A		A
All electrical system* ⁵			I	I	I	I	I	I	I	I
Head lamp alignment				A		A		A		A

Chassis and body

Clutch pedal (with cable adjustment)			I	I	I	I	I	I	I	I
Clutch fluid			I	I	I	I	I	I	I	I
Brake lines, hoses and connections				I		I		I		I
Brake pedal			I	I	I	I	I	I	I	I
Brake fluid* ⁶			I	I	I	R	I	I	I	R
Parking brake				A		A		A		A

See footnote on page 6-5 for explanation of asterisk followed by number (e.g. *1) and letter codes used in this chart.

SCHEDULED MAINTENANCE SERVICES (cont'd)

Maintenance Item	Maintenance Interval	Number of Months or Km (Miles), whichever comes first										
		Months* ¹		12		24		36		48		
		x1000	Km	1.0	10	20	30	40	50	60	70	80
			Miles	0.6	6	12	18	24	30	36	42	48

Chassis and body (cont'd)

Power brake unit and hoses				I		I		I		I	
Disc brakes				I		I		I		I	
Power steering fluid			I	I	I	I	I	I	I	I	I
Power steering system and hoses				I		I		I		I	
Steering and front suspension				I		I		I		I	
Transmission oil							A				R
Rear axle oil							A				R
Wheel bearing grease											A
Bolts and nuts on chassis and body		T		T		T		T		T	
Body condition (for rust, corrosion and perforation)							Inspect annually				
Exhaust system heat shields (unlead)							I				I
Tires (including spare tire) (with inflation pressure adjustment)				I		I		I		I	
Hinges and catches				A		A		A		A	
Underside of vehicle				I		I		I		I	
Seat belt				I		I		I		I	
Toe control hub and control link							I				I
Road test						I		I		I	

See footnote on page 6-5 for explanation of asterisk followed by number (e.g. *1) and letter codes used in this chart.

Chart symbols:

- I:** Inspect: Visual examination and/or functional measurement of a system's operation or performance
- A:** Adjust: Examination resulting in adjustment or replacement
- R:** Replace or change
- T:** Tighten

Remarks:

After 80,000 km (48,000 miles) or 48 months, continue to follow the described scheduled maintenance items and periodically.

As for * marked items in this maintenance chart, please pay attention to the following points.

- *1 Major service interval at 12 months/20,000 km (12,000 miles)
Lubrication service based on distance only 10,000 km (6,000 miles) not time.
- *2 Adjust alternator and water pump drive belt, power steering and air conditioner drive belt, if equipped.
- *3 If the vehicle is operated under the following conditions, it is suggested that the engine oil and oil filter be changed more often than at usual recommended intervals.
 - a) Driving in dusty conditions
 - b) Extended periods of idling or low speed operation.
 - c) Driving for a prolonged period in cold temperatures or driving only short distance regularly.
- *4 If the vehicle is operated in very dusty or sandy areas, inspect and, if necessary, replace more often than at usual recommended intervals.
- *5 This is a full function check of all electrical systems, i.e. all lights, washers (including condition of blades) electric windows, sun roof, horn, etc...
- *6 Replace every two years
If there has been continuous hard driving, mountain driving, or if the brakes are used extensively or the vehicle is operated in extremely humid climates, the brake fluid should be changed annually.

Emission Control and Related Systems:

The ignition and fuel systems are vitally important to the proper operation of the emission control and related systems, as well as for efficient engine operation. It is strongly recommended that all servicing related to these systems be done by your Authorized Mazda Dealer.

SCHEDULED MAINTENANCE SERVICES (Except European models)

MAINTENANCE INTERVAL MAINTENANCE ITEM	Number of months or km, whichever comes first										
	Months		—	6	12	18	24	30	36	42	48
	x1000	Km	1.0	10	20	30	40	50	60	70	80
Miles		0.6	6	12	18	24	30	36	42	48	

Engine

Drive belt **1	A	I	I	I	I	I	I	I	I	I
Engine oil **1		R	R	R	R	R	R	R	R	R
Oil filter **1		R	R	R	R	R	R	R	R	R
Engine oil (Turbo only)	Replace every 5,000 km/6 months									

Cooling system

Cooling system			I		I		I		I	
Engine coolant	Replace every 2 years									

Fuel system

Idle speed		I		I		I		I		I
Idle mixture		I		I		I		I		I
Air cleaner element **2						R				R
Fuel filter						R				R
Fuel lines and hoses			I			I		I		I

* See page 6-9 for detailed information.

SCHEDULED MAINTENANCE SERVICES (Cont'd)

MAINTENANCE INTERVAL MAINTENANCE ITEM	Number of months or km, whichever comes first									
	Months	—	6	12	18	24	30	36	42	48
	x1000	Km	1.0	10	20	30	40	50	60	70
	Miles	0.6	6	12	18	24	30	36	42	48

Ignition system

Initial ignition timing											
Spark plugs											

Evaporative emission control system

Evaporative system (For Saudi)											
--------------------------------	--	--	--	--	--	--	--	--	--	--	--

Exhaust emission control system

Dash pot											
----------	--	--	--	--	--	--	--	--	--	--	--

Electrical system

Battery electrolyte level and specific gravity											
--	--	--	--	--	--	--	--	--	--	--	--

SCHEDULED MAINTENANCE SERVICES (Cont'd)

MAINTENANCE INTERVAL \ MAINTENANCE ITEM	Number of months or km, whichever comes first										
	Months		—	6	12	18	24	30	36	42	48
	x1000	Km	—	10	20	30	40	50	60	70	80
		Miles	—	6	12	18	24	30	36	42	48

Chassis and body

Clutch pedal			I	I	I	I	I	I	I	I
Clutch fluid			I	I	I	I	I	I	I	I
Brake lines, hoses and connections				I		I		I		I
Brake pedal			I	I	I	I	I	I	I	I
Brake fluid *4			I	I	I	R	I	I	I	R
Parking brake			I	I	I	I	I	I	I	I
Power brake unit and hoses				I		I		I		I
Disc brakes			I	I	I	I	I	I	I	I
Drum brakes				I		I		I		I
Power steering fluid and line (if equipped)			I	I	I	I	I	I	I	I
Steering operations and gear housing			I	I		I		I		I
Steering linkages, rack guide and tie rod ends			I	I		I		I		I
Manual transmission oil										R
Automatic transmission fluid				I		I		I		I
Rear axle oil										R
Front suspension ball joints						I				I
Front wheel bearing grease										R
Drive shaft dust boots				I		I		I		I
Bolts and nuts on chassis and body			T		T		T		T	
Control hub and link						I				I

* See page 6-9 for detailed information.

Chart symbols:

I: Visual examination or functional measurement of a system's operation (performance)

A: Adjust

R: Replace or change

T: Tighten

NOTE:

As the result of visual examination or functional measurement of a system's operation (performance), correct, clean or replace as required.

REMARKS:

- After 80,000 km or 48 months, continue to follow the described maintenance items and intervals periodically.
- As for * marked items in this maintenance chart, please pay attention to the following points.
 - *1 If the vehicle is operated under the following conditions, it is suggested that the engine oil and oil filter be changed more often than at usual recommended intervals.
 - a) Driving in dusty conditions
 - b) Extended periods of idling or low speed operation
 - c) Driving for a prolonged period in cold temperatures or driving only short distances regularly.
 - *2 If the vehicle is operated in very dusty or sandy areas, inspect and, if necessary, replace more often than at usual recommended intervals.
 - *3 Adjust or inspect alternator and water pump drive belt, and water pump drive belt and power steering and air conditioner drive belt if equipped.
 - *4 Replace every two years.
If there has been continuous hard driving, mountain driving, or if the brakes are used extensively or the vehicle is operated in extremely humid climates, the brake fluid should be changed annually.

Emission Control and Related Systems:

The ignition and fuel systems are vitally important to the proper operation of the emission control and related systems, as well as for efficient engine operation. It is strongly recommended that all servicing related to these systems be done by your Authorized Mazda Dealer.

ROUTINE SERVICES

It is strongly recommended that following items be checked daily and/or weekly.

- **ENGINE OIL LEVEL**
(See page 6-13.)
- **WASHER FLUID LEVEL**
(See page 6-14.)
- **ENGINE COOLANT LEVEL**
(See page 6-15.)
- **BRAKE AND CLUTCH FLUID LEVELS**
(See page 6-16.)
- **TIRE INFLATION PRESSURE**
(See page 6-18.)

MAINTENANCE SERVICE PRECAUTIONS

When performing any inspection or maintenance work on your vehicle, always exercise care to prevent personal injury to yourself or damage to the vehicle. Here are some general precautions that should be closely observed in carrying out any service operation.

- Do not work on the engine while it is hot. Always turn it off and allow it to cool.
- If you must work with the engine running, make sure that no article of clothing, including ties and handkerchiefs, can become entangled with any moving parts. Remove watches, bracelets, rings, necklaces, and similar items. Keep hands, clothing, hair, and tools away from moving fan and drive belts.
- Never get under the vehicle while it is supported by a jack. If it is necessary to work under the vehicle, use safety stands.
- Keep smoking materials, flames and sparks away from all fuel and fuel-related parts and the battery.
- Never connect or disconnect either the battery or any transistorized component while the ignition switch is on.

- When connecting the battery cables, pay particular attention to their polarities. Never connect the positive cable to a negative terminal or a negative cable to a positive terminal.
- Remember that battery and ignition cables carry high-voltage currents. Be careful not to cause a short circuit.
- When performing any checks with the engine running in an enclosed space, such as in a garage, be sure there is proper ventilation.

You should be aware that improper or incomplete service may result in operating problems. This section gives instructions only for those items that are relatively easy for an owner to perform. As explained in Scheduled Maintenance, there are still a number of items that must be done by a qualified service technician with special tools. Improper performance of maintenance during the warranty period may affect your warranty coverage. Read the separate Mazda Warranty statement for details. If in doubt about any service, have it done by an Authorized Mazda Dealer.

ENGINE COMPARTMENT

- | | |
|--------------------------------------|---------------------------------------|
| 1. Spark plugs | 10. Battery terminals |
| 2. Engine oil filler cap | 11. Drive belts |
| 3. Oil filter | 12. Air cleaner |
| 4. Engine oil level gauge (dipstick) | 13. Windshield washer fluid reservoir |
| 5. Brake fluid reservoir | 14. Radiator cap |
| 6. Clutch fluid reservoir | 15. Intercooler |
| 7. Power steering fluid filler cap | 16. Headlight washer reservoir |
| 8. Main fuse block | |
| 9. Radiator coolant reservoir | |
- * if equipped

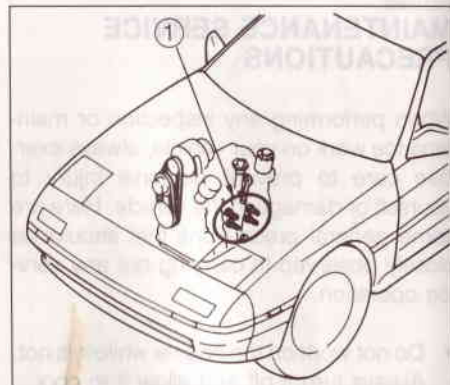

(Non-turbo models)

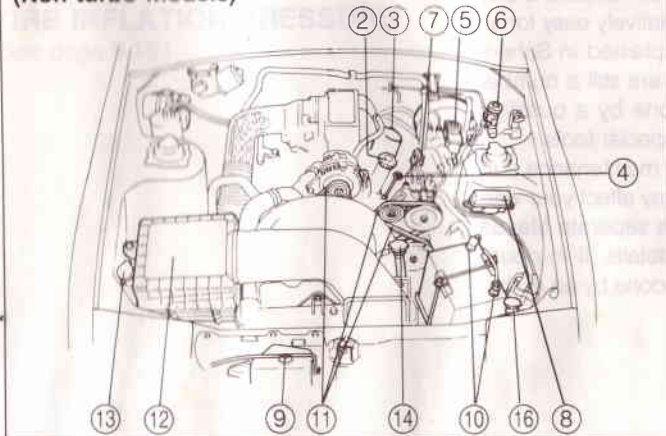

(Turbo models)

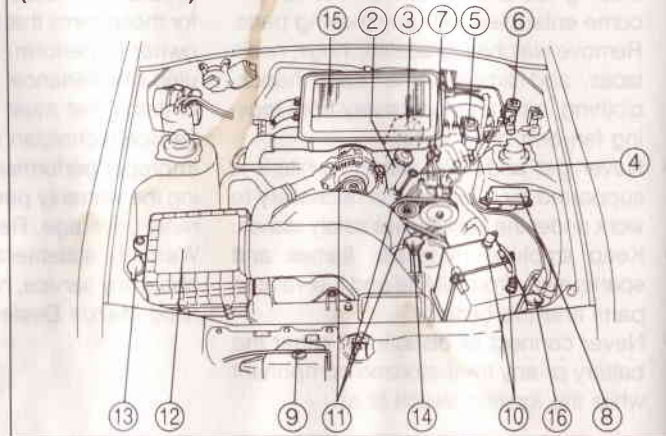

CHECKING ENGINE OIL LEVEL

1. Be sure the vehicle is on level ground.
2. Warm up the engine to the normal operating temperature.
3. Turn the engine off and wait five minutes.
4. Pull out the dipstick, wipe it clean, and reinsert it fully.
5. Pull the dipstick out again and note the reading. If the level is between the F and L marks, it is adequate.

If it is near or at the L line, add enough oil to bring the level to the F line.

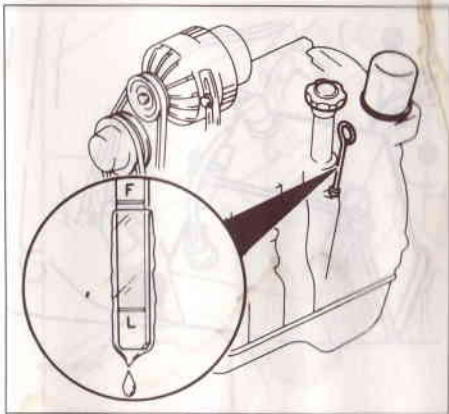

NOTE

Distance between the L and F marks on the dipstick represents the following.

1.0 liter (1.05 US qt, 0.87 Imp qt)

CHECKING WASHER FLUID LEVEL

WINDSHIELD WASHER FLUID LEVEL

The washer fluid levels can be checked through the function of the washer fluid low level warning light only.

If the warning light comes on, add washer fluid as soon as possible.

In cold weather, use washer fluid to prevent freezing.

CAUTION

Do not use radiator anti-freeze for washer fluid. This may result in damage to the paint.

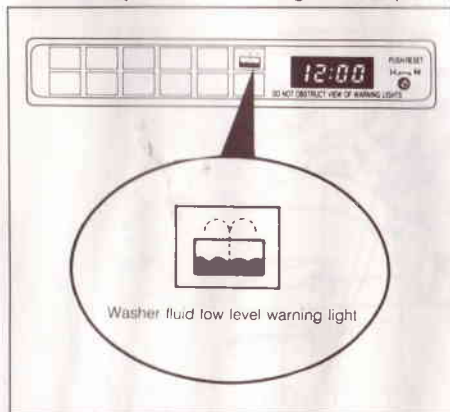

The reservoir is located at the right front fender.

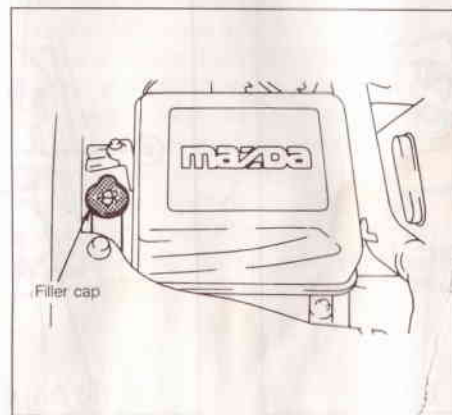

HEADLIGHT WASHER FLUID LEVEL

The reservoir is located at the left front fender.

CAUTION

Do not use radiator anti-freeze for washer fluid. This may result in damage to the paint.



REAR WINDOW WASHER FLUID LEVEL (if equipped)

Plain water may be used if washer fluid is not available. However, in cold weather, use washer solution to prevent freezing.

CAUTION

Do not use radiator anti-freeze for washer solution. This may result in damage to the paint.

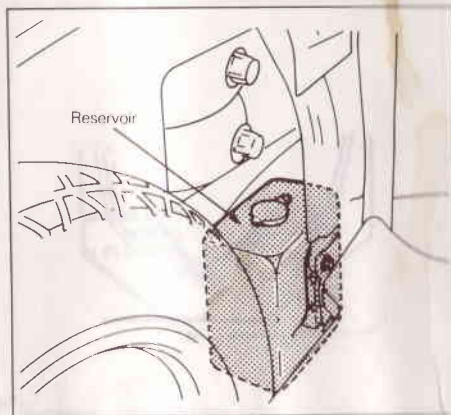

CHECKING ENGINE COOLANT LEVEL

WARNING!

- Never attempt to remove the radiator cap while the engine is operating. Doing so might lead to cooling system and engine damage and could result in serious personal injury from escaping hot coolant or steam. Turn off the engine and wait until it has cooled. Even then, use extreme care when removing the radiator cap. Wrap a thick cloth around it, and turn it slowly to the first stop. Step back while the pressure is being released from the cooling system. When you are sure all the pressure has been released, press down on the cap—still using a cloth—turn it, and slowly remove it.
- Even if the engine is not operating, do not remove the radiator cap while the engine and radiator are hot. Scalding hot coolant and steam may still blow out under pressure, which could cause serious injury.

The coolant level should be full in the radiator and between the FULL and LOW marks on the coolant reservoir when the engine is cool.

If the level is near or at the LOW mark, add enough specified coolant (see page 6-24 for cooling system), to bring the level to the FULL mark.

Do not OVERFILL. If frequent additions are required, see an Authorized Mazda Dealer for a cooling system inspection.

CAUTION

Radiator coolant will damage paint. Quickly rinse any spilled coolant from painted surfaces.

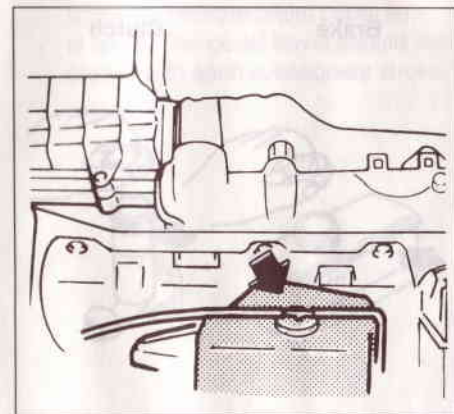

CHECKING BRAKE AND CLUTCH FLUID LEVEL

Before checking the fluid level, clean the area around the reservoir cap thoroughly. The fluid level must be kept at the MAX level line.

If the fluid level is near or at the MIN level line, add the fluid to the MAX level line.

CAUTION

- Use only the specified brake and clutch fluid (refer to chart on page 6-19).
- Do not mix different types of fluid.
- In the event the brake or clutch system requires frequent supplies of fluid, the vehicle should be inspected by your Authorized Mazda Dealer.
- Use caution in filling the reservoirs because brake fluid can harm your eyes and damage painted surfaces.

• Checking brake pedal freeplay

Turn off the engine and depress the brake pedal several times in order to deplete the vacuum in the power brake unit. Gently depress the brake pedal by hand and measure the distance it moves until slight resistance is felt.

If the freeplay is more or less than specification, have the brakes adjusted by your Authorized Mazda Dealer.

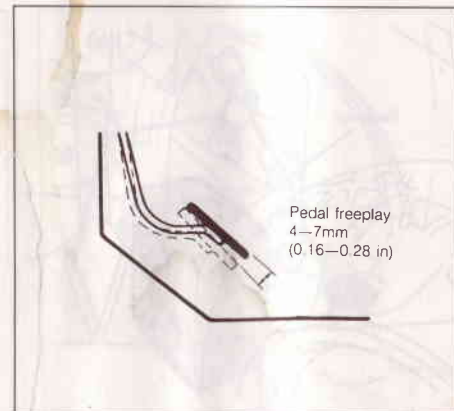
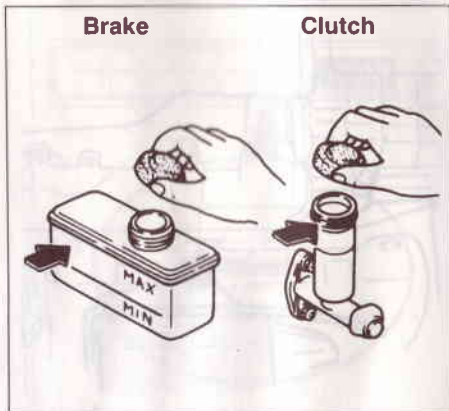

• Checking brake pedal clearance

Start the engine and check the brake pedal for smooth operation and proper clearance when it is fully depressed (approximately 589 N [60 kg, 132 lb]). The clearance is measured between the center of the upper surface of the brake pedal pad and the floorboard.

If the clearance is less than about 100mm (3.94 in), have the brakes adjusted by your Authorized Mazda Dealer.



97E6 0130E

CHECKING PARKING BRAKE

After depressing the brake pedal several times, check the stroke of the parking brake by counting the number of clicks heard while fully applying it from the released position. Also, the parking brake alone should securely hold the vehicle on a fairly steep grade. If the number of clicks is more or less than specification, have the parking brake adjusted by your Authorized Mazda Dealer.

Stroke: 5—7 clicks at a force of 98 N (10 kg, 22 lb)

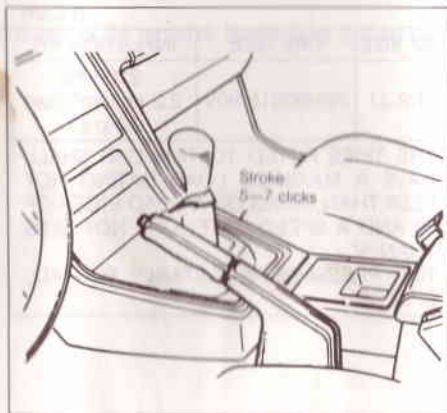

97E6 0140E

CHECKING POWER BRAKE UNIT AND HOSES

- Check the vacuum hoses, connectors, and check valve for cracks, chafing, and deterioration.
- Check the power brake unit for proper operation as described below.
 - Depress the brake pedal a few times and then hold it down. Start the engine and the pedal should drop slightly.
 - Depress the brake pedal, stop the engine and hold the pedal down for approx. 30 seconds. The pedal should neither drop nor rise.
 - Restart the engine and let it run for about 1 minute and turn it off. Then firmly depress the brake pedal several times. The pedal travel should decrease with each subsequent stroke.

CHECKING TIRE INFLATION PRESSURES

All tire pressures (including the spare) should be checked monthly when the tires are cold. Recommended pressures must be maintained for the best ride, top vehicle handling and minimum tire wear.

Refer to the tire pressure chart label (see page 7-3) or tire specification charts shown on this page.

NOTE

Warm tires normally exceed pressures recommended by the tire manufacturers; therefore, do not release air from warm tires to adjust the pressure.

WARNING!

Overinflation or underinflation can reduce tire life, adversely affect vehicle handling and lead to sudden tire failure. This could result in an unexpected loss of vehicle control.

European models (Except cabriolet models)

(FC39)			
RIM SIZE	TIRE SIZE	UNDER 200km/h	OVER 200km/h
7JJ	205/55ZR16	220 kPa 2.2 kgf/cm ² (bar) 32 p.s.i.	240 kPa 2.4 kgf/cm ² (bar) 35 p.s.i.
THE TIRES FITTED TO THIS CAR SHALL HAVE A MAXIMUM LOAD RATING NOT LESS THAN 580KG OR A LOAD INDEX OF 89 AND A SPEED CATEGORY NOT LESS THAN 'V'.			

(Cabriolet models)

(FC54)			
RIM SIZE	TIRE SIZE	INFLATION PR.	
61/2-JJ	205/60R15 90V	220 kPa 2.2 kgf/cm ² (bar) 32 p.s.i.	
THE TIRES FITTED TO THIS CAR SHALL HAVE A MAXIMUM LOAD RATING NOT LESS THAN 580KG OR A LOAD INDEX OF 89 AND A SPEED CATEGORY NOT LESS THAN 'V'. TIRE PRESSURE IS SUITABLE FOR ALL SPEEDS.			

Except European models

(FB25B)		
RIM SIZE	TIRE SIZE	INFLATION PR.
6-JJ	205/60VR15	220 kPa 2.2 kgf/cm ² (bar) 32 p.s.i.
THE TIRES FITTED TO THIS CAR SHALL HAVE A MAXIMUM LOAD RATING NOT LESS THAN 580KG OR A LOAD INDEX OF 89 AND A SPEED CATEGORY NOT LESS THAN 'V'. TIRE PRESSURE IS SUITABLE FOR ALL SPEEDS.		

RECOMMENDED LUBRICANTS

Item	Classification	Service intervals
Engine oil* ¹	API Service SD, SE or SF (Mineral oil only)	NOTE Refer to the scheduled maintenance chart.
Transmission oil* ¹	API Service GL-4, GL-5	
Power steering fluid	ATF Dexron [®] II or M-III	
Rear axle oil* ¹	API Service GL-5	
Wheel bearing grease	NLGI No. 2 (Lithium base)	
Multi-purpose grease	NLGI No. 2 (Lithium base)	
Brake and clutch fluid* ²	SAE J1703, or FMVSS116 DOT 3	

*¹ See page 6-20 for detailed information.

*² Change brake fluid every 40,000km (24,000 miles) or 24 months. Brake fluid should be changed annually under the following conditions:

- Continuous hard driving
- Operation in extremely humid climates
- Mountain driving
- Extensive use of brakes

RECOMMENDED SAE VISCOSITY NUMBERS

Temperature	°C											
	(°F)		-30	-20	-10	0	10	20	30	40	50	
			-20	0	20	40	60	80	100	120		
Engine oil	5W-30		▶									
	5W-20		▶									
	10W-30		▶									
	10W-40		▶									
	10W-50		▶									
Rear axle oil	80W		▶									
	90		▶									
Transmission oil	80W-90		▶									
	75W-90		▶									

NOTE

When you change or add oil, select the proper SAE viscosity. Check the accompanying table and select the one that most closely matches the temperature range you expect to encounter.

CAUTION BEFORE CHECKING LUBRICANTS:

Always be sure to clean the area around any filler plug, drain plug or dip stick before checking or draining any lubricant. This is especially important in dusty/sandy areas or when the vehicle is used on unpaved roads. Cleaning the plug and dipstick areas will prevent dirt and grit from entering the engine or other areas which could be damaged.

ENGINE OIL AND OIL FILTER

WARNING!

- Stop the engine before removing the oil filter or changing the engine oil. Only when the engine has cooled a little should you proceed to change the oil and replace the oil filter.
- Continuous contact with USED engine oil has caused skin cancer in laboratory mice. Protect your skin by washing with soap and water. Keep out of the reach of children.

CAUTION

- Follow these instructions carefully. An improper oil filter installation can cause oil leakage and engine damage.
- Although oil filters may have the same external appearance, their internal designs are significantly different, and these filters are not interchangeable. To avoid any potential engine damage, use only the specified filter for each application.

CHANGING ENGINE OIL

1. Drain the oil by removing the oil filler cap and drain plug while the engine is warm, **Be careful not to burn yourself.**
2. Replace the drain plug tightly, after the oil has thoroughly drained.
3. Refill the engine with new oil to the F level marked on the dipstick. **Do not overfill.**
4. Refit the oil filler cap securely.

NOTE

Use only the specified engine oil (refer to chart on page 6-19).

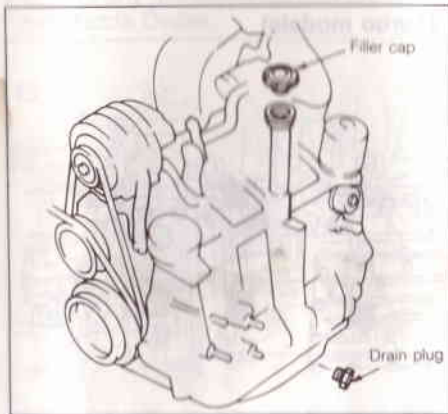

CHANGING OIL FILTER

1. Remove the engine oil filter with a suitable wrench.
2. Use a clean rag to wipe off the mounting surface on the engine.
3. Apply a small amount of engine oil to the rubber seal of the new oil filter.
4. Install the oil filter and tighten it. (Please refer to oil filter caution label for tightening instructions.)
5. Start the engine and inspect around the oil filter seal for leaks. Check the oil level and fill to the F mark if necessary.

Oil filter capacity:

0.17 liter (0.18 US qt, 0.15 Imp qt)

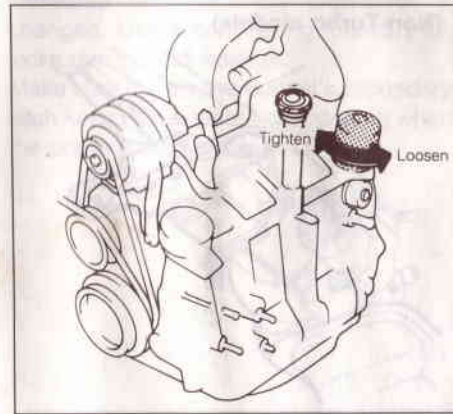

CHANGING TRANSMISSION OIL

1. Remove drain plug A and check plugs B (Non-turbo models) or B and C (Turbo models).
2. Wipe the drain plug clean.
3. After the oil has drained, install and retighten the drain plug.
4. **(Non-Turbo models)**
Add lubricant until the level reaches the bottom of the check plug hole.
(Turbo models)
Add lubricant from plug B port until it reaches the bottom of check plug C hole.

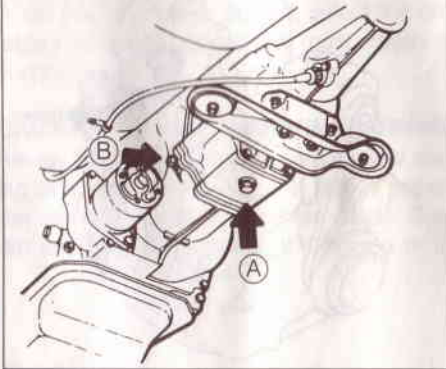
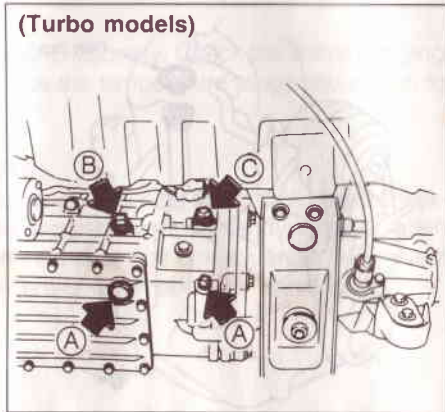
(Non-Turbo models)**(Turbo models)****CHECKING POWER STEERING PUMP FLUID LEVEL**

Check the fluid level in the pump each time the engine oil is changed. Add fluid if necessary. The fluid does not require periodic changing.

The level must be kept between the H and L level when fluid is cold.

Visually check the lines and hoses for leaks or damage.

CAUTION

To avoid damage to the power steering pump do not operate the vehicle for prolonged periods with a low power steering pump fluid level.

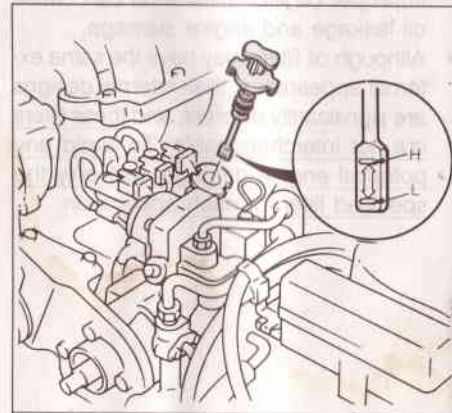

NOTE

Use only the specified power steering fluid (refer to chart on page 6-19).

Do not overfill. If overfilled, remove excess fluid with a suction device.

In the event the power steering system requires frequent supplies of fluid, the vehicle should be inspected by your Authorized Mazda Dealer.

97E6-0230E

CHANGING REAR AXLE OIL

1. Remove drain plug A and filler plug B while the oil is still warm.
2. Wipe the magnetic drain plug clean.
3. After the oil has drained completely, install and retighten the drain plug.
4. Refill with new oil until it reaches the bottom of the filler plug hole.
5. Install and retighten the filler plug.

NOTE

If your vehicle is equipped with a limited-slip differential, it requires API GL-5, SAE90 special lubricant for limited-slip differentials.

If you are not sure whether your vehicle is equipped with a limited-slip differential, or if you have any questions, contact an Authorized Mazda Dealer.

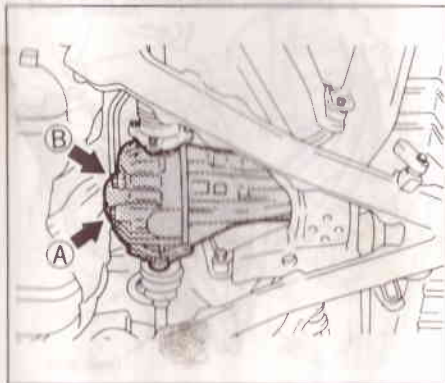

97E6-0240E

WHEEL BEARINGS

Consult your Authorized Mazda Dealer for proper detailed adjustment procedures and specifications.

97E6-0250E

STEERING LINKAGE

If the vehicle is used in very dusty or sandy areas, have this inspection done frequently. The steering linkage should be inspected for proper operation at each service.

76A6-0200E

BODY LUBRICATION

All moving points of the body, such as door and bonnet hinges and locks, should be lubricated each time the engine oil is changed. Use a nonfreezing lubricant on locks during cold weather.

Make sure the engine bonnet's secondary latch keeps the bonnet from opening when the primary latch is released.

COOLING SYSTEM

The cooling system is a high-pressure type with a see-through coolant reservoir and is filled with year-round coolant at the factory.

CAUTION

- The engine in your vehicle has aluminum engine parts and must be protected by the an ethylene glycol base coolant to prevent corrosion or freezing. **DO NOT USE** alcohol or methanol antifreeze, or mix them with the specified coolant.
- Do not use a solution that contains more than 60 percent antifreeze, which would reduce the effectiveness of solution.

For mixture percentage, refer to the table below.

Protection	Mixture percentage (volume) %	
	Anti-freeze solution	Water
Above -16°C (3°F)	35	65
Above -26°C (-15°F)	45	55
Above -40°C (-40°F)	55	45

Check the anti-freeze protection and coolant level in the radiator at least once a year—at the beginning of the winter season—and before traveling to a colder climate.

CHECKING COOLING SYSTEM

Check the condition and connections of all cooling system hoses and heater hoses. Replace any swollen or deteriorated hoses.

CHANGING COOLANT

CAUTION

- Do not use alcohol- or methanol-based coolants.
- Use only soft (demineralized) water in the coolant mixture.

WARNING!

- See warning on page 6-15 in regard to radiator cap removal.

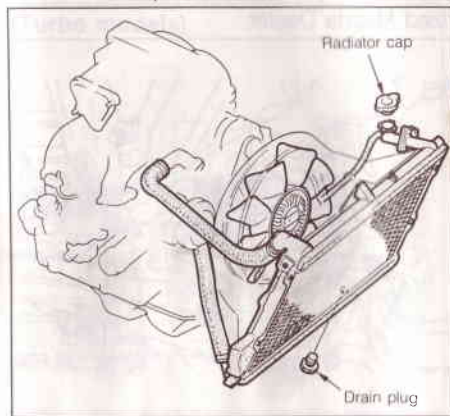

- Do not loosen the drain plug when the engine is hot.

1. Remove the radiator cap.
2. Loosen the radiator drain plug, and let the coolant drain.
3. Move the temperature control lever to the extreme right side.
4. With the drain plug left loose flush the system out with water.
5. Let the system drain completely and retighten the drain plug. Add the necessary amount of ethylene-glycol coolant and water to provide the required freezing and corrosion protection. In extremely cold climates, add the necessary amount of ethylene glycol-based coolant in accordance with the instructions of the coolant manufacturer.
6. Run the engine at idle speed with the radiator cap removed, and slowly add additional coolant if necessary.
7. At this point, wait until the engine reaches normal operating temperature. Depress the accelerator two or three times; then add coolant if required.
8. Install the radiator cap. Inspect all connections for leaks and recheck the coolant level in the reservoir.

AIR CLEANER

If the vehicle is operated in very dusty or sandy areas, it is recommended that the element be replaced more often than at the usual recommended intervals. When replacement is necessary, you should use only the Mazda genuine air cleaner element or one of equal quality which meets Mazda specifications.

CAUTION

Do not remove the air cleaner unless temporary removal is necessary during repair or maintenance of the vehicle.

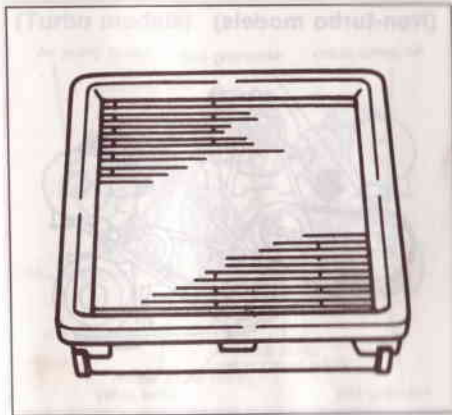

SPARK PLUGS

If necessary, clean the electrodes with a fine wire brush and carefully file the carbon off the insulator with a small file.

The plugs should then be blown clean with compressed air and the upper insulator wiped clean.

Recommended Spark Plugs (For European models)

NGK	BUR9EQ
-----	--------

(Except European models)

	Leading	Trailing
NGK	BR9ET	BR10ET
NIPPONDENSO	W27EBR	W29EBR

(Except European models)

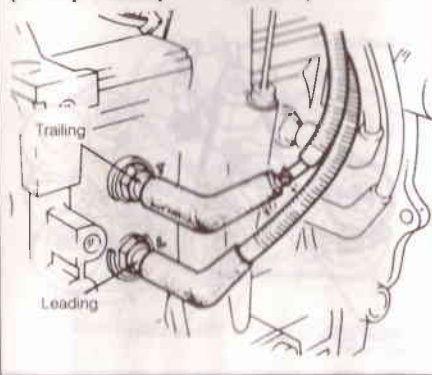

CAUTION

- Do not use conventional types of abrasive spark plug cleaners because sand may remain inside the plug and later cause damage to the engine.
- (Except European models)**
When you replace the spark plugs, make sure that you do not mix the Leading and Trailing sides.

NOTE

- When installing the plugs, use a small amount of anti-seize compound or molybdenum-based thread lubricant on the first few threads.
- When removing the spark plug cables, pull on the boot, not on cable itself.

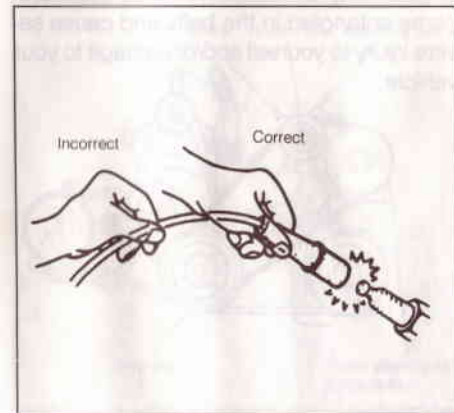

CHECKING BELT TENSION

Apply moderate thumb pressure (approximately 98N, 10 kg, 22 lbs) midway between pulleys, and check the deflection.

NOTE

If the drive belt becomes worn, cracked or frayed, it should be replaced.

WARNING!

Keep hair, loose clothing, neckties, necklaces, etc. away from drive belts especially when the engine is running. ALWAYS REMOVE ALL TOOLS from the engine compartment before attempting to start the engine. Any of the above items could become entangled in the belts and cause severe injury to yourself and/or damage to your vehicle.

Alternator drive belt

1. Loosen the alternator mounting bolt and adjusting bar bolt.
2. Move the alternator to obtain proper belt tension.
3. Tighten the bolts and recheck the tension.

Deflection	New	12–15mm
	Used	14–17mm

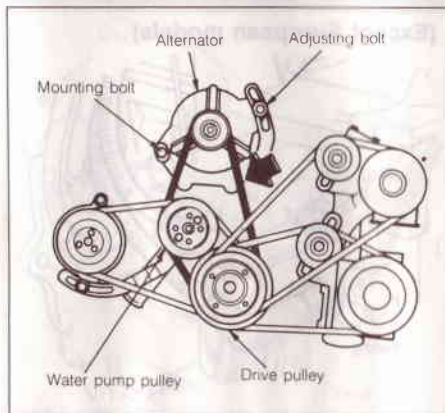

Air pump drive belt

1. Loosen the air pump mounting bolt and adjusting bar bolt.
2. Move the air pump to obtain proper belt tension.
3. Tighten the bolts and recheck the tension.

Deflection	New	9–11mm	
	Used	When applying pressure	11–13mm
		*When pulling	12–14.5mm

*Turbo models

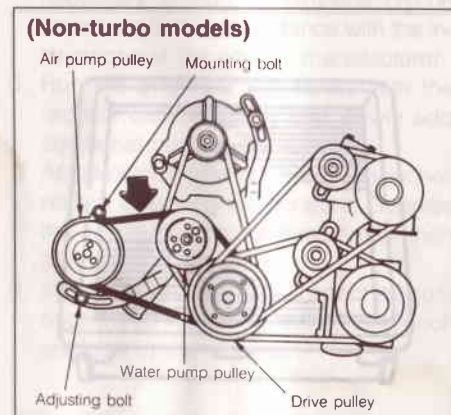

FUSES

The only specified fuse is the one used in the engine compartment. If an electrical failure occurs, check for a blown fuse and replace as necessary. If the fuse has blown again, avoid using the system involved and have the system immediately repaired by your Authorized Mazda Dealer.

CAUTION

Always replace a blown fuse with the same rating as specified.

Never install a fuse that is the wrong size even for a temporary repair. It may cause electrical damage and possibly a fire.

Air conditioner drive belt (if equipped)

1. Loosen the lock nut on the idler pulley.
2. Turn the adjusting bolt until the correct tension is obtained.
3. Tighten the lock nut and recheck the tension.

Deflection	New	6–8mm
	Used	8–9mm

Power steering pump drive belt (if equipped)

1. Loosen the lock nut on the idler pulley.
2. Turn the adjusting bolt until the correct tension is obtained.
3. Tighten the lock nut and recheck the tension.

Deflection	New	11–13mm
	Used	14–16mm

(Turbo models)

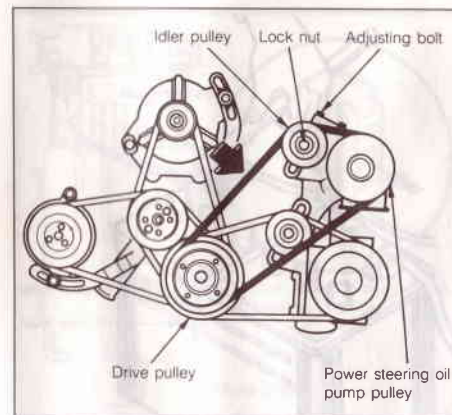
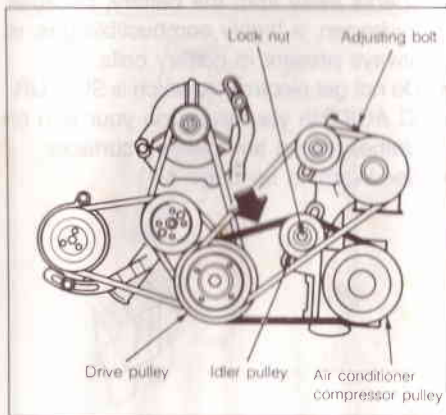
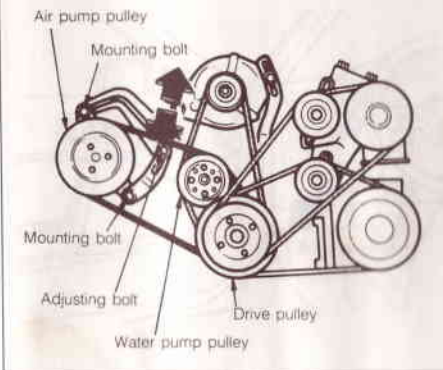

BATTERY

Inspect the electrolyte level at least once a week. If it is low, add enough distilled water to keep between upper level and lower level. Do not overfill.

The specific gravity of the electrolyte should be examined with a hydrometer, particularly during cold weather. If the reading is low, have the battery recharged.

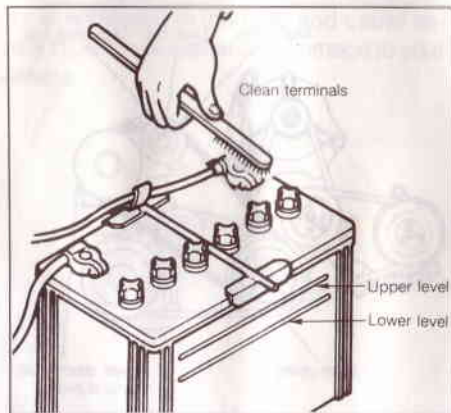

For the best service from your vehicles battery, follow these tips.

1. Keep the battery securely mounted.
2. Keep the battery top clean and dry.
3. Keep the terminals and connections clean and tight and the terminals coated with petroleum jelly or terminal grease.
4. Rinse off any spilled electrolyte immediately with a solution of water and baking soda.
5. If the vehicle is not being used for an extended time, disconnect the cables and charge the battery every six weeks.

WARNING!

- Keep lighted cigarettes, flames and sparks away from the battery, because hydrogen, a highly combustible gas, is always present in battery cells.
- Do not get electrolyte, which is SULFURIC ACID, in your eyes, on your skin or clothes, or on any painted surfaces.
- See Warning on page 4-1.

FUSES

Use only specified fuses if replacement is necessary. If an electrical failure occurs, check for a blown fuse and replace as necessary. If the same fuse blows again, avoid using the system involved and bring the problem immediately to the attention of your Authorized Mazda Dealer.

CAUTION

Always replace a blown fuse with the same rating as specified.
Never install a wire instead of the proper fuse even for a temporary repair. It may cause extensive damage and possibly a fire.

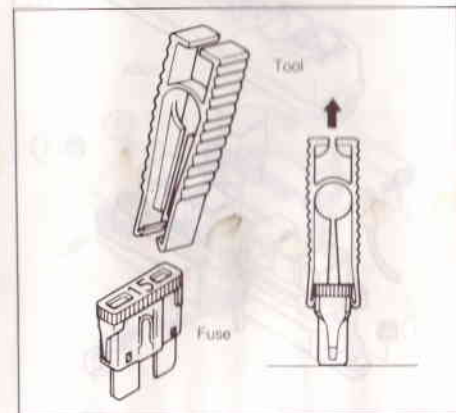
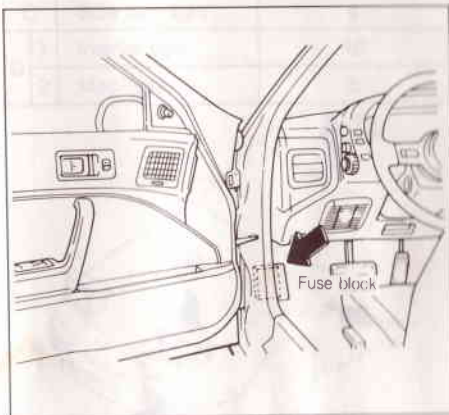

Do not use a screwdriver or any other metal object to remove fuses, as an electrical short circuit may occur and damage the system.

When replacing a fuse, turn the Ignition switch off. Pull the blown fuse straight out using the removal tool provided. Push a new one in place.

Because the heater, air conditioner and rear window defroster consume a large amount of power, circuit breakers are provided in their circuits for safety.

If the circuit is broken by the circuit breaker, turn all heater and air conditioner switches off and restore the circuit by pushing the reset button. If the circuit breaks again, have the vehicle inspected by an Authorized Mazda Dealer.

1. For heater/air conditioner.
2. For rear window defroster.

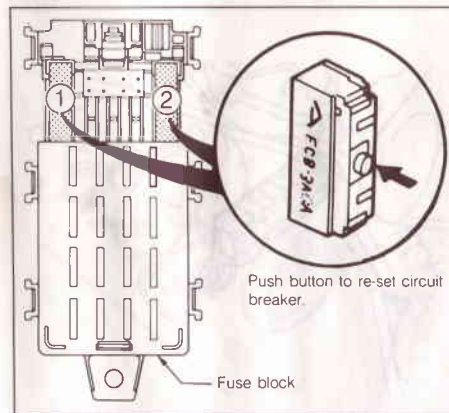

Main fuse block

If the headlights or other electrical components do not work and the fuses in the passenger's compartment are O.K., check the main fuses. In the engine compartment open the cover over the main fuses by lifting the tab on the cover end. Then tilt the cover up and away. If a fuse is melted, it must be replaced.

Replacing a main fuse

When replacing a fuse, make sure the ignition switch is off. For all main fuses EXCEPT the 100A central fuse, pull the blown fuse straight up and out. Push a new one in place. For the 100A fuse, see the following note.

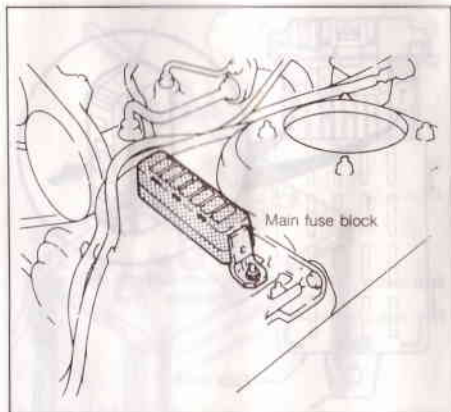

NOTE

When replacing the 100A fuse, follow these steps:

1. Disconnect the battery negative cable.
2. Remove the nuts 1, holding the fuse block, to gain access to the 100A fuse bolts 2. Remove as in the illustration.

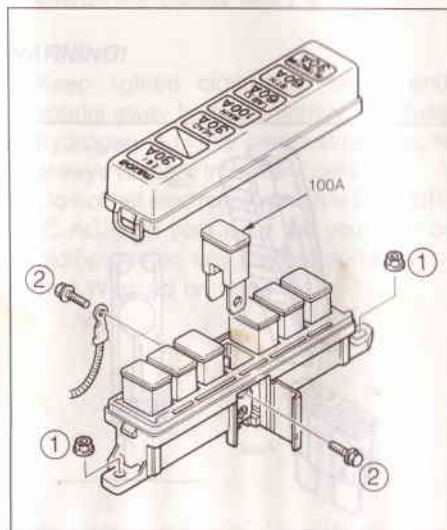

LIGHT BULBS**FRONT**

	Light bulb	Wattage	
		For European models	Except European models
A	Headlight High/Low	60/55	65/35
	Running light (models for Sweden and Norway)	55	
B	1 Turn signal light	21	27
	2 Parking light	5	8
C	Side turn light	4	
D	1 Interior light	10	
	2 Map light	5	

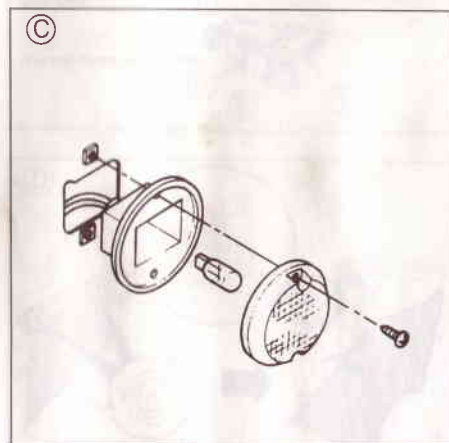
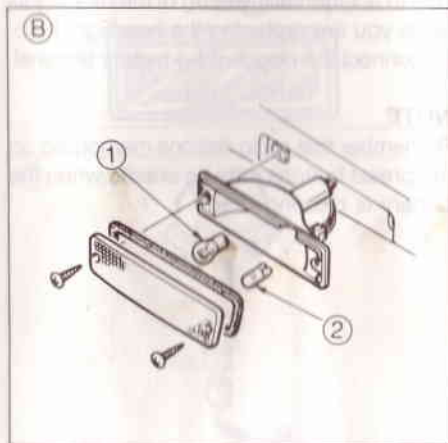
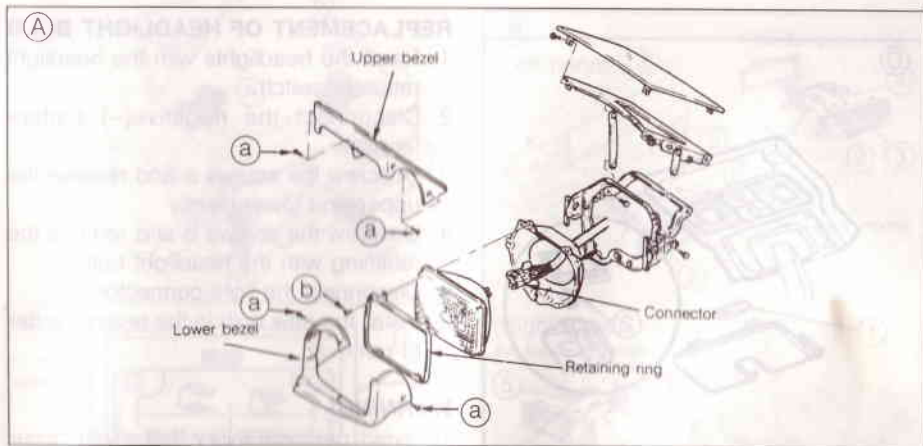
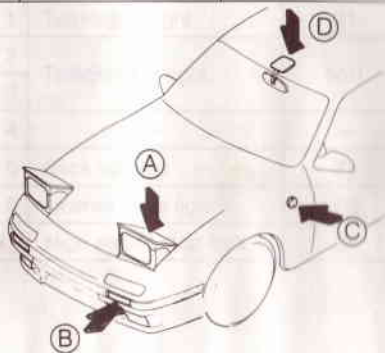

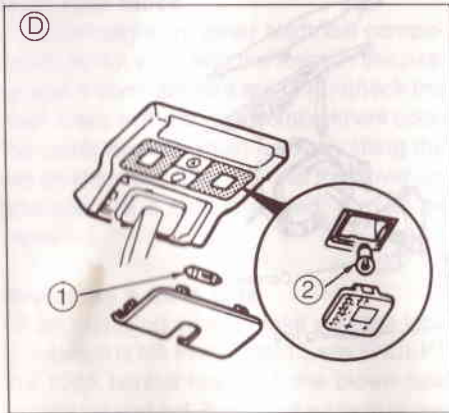

REPLACEMENT OF HEADLIGHT BULB

1. Raise the headlights with the headlight retractor switch.
2. Disconnect the negative(-) battery terminal.
3. Unscrew the screws a and remove the upper and lower bezel.
4. Unscrew the screws b and remove the retaining with the headlight bulb.
5. Disconnect the light connector.
6. Install the new bulb in the reverse order of removal.

WARNING!

To avoid personal injury that might occur due to accidental lowering of the headlights while you are replacing the headlight bulb, disconnect the negative (-) battery terminal.

NOTE

Remember that radio stations memorized on the preset buttons may be erased when the battery is disconnected.

CAUTION

- Halogen bulbs contain pressurized gas which will produce flying pieces of glass if broken. Therefore, always handle carefully, and avoid scratching or abrasion of the bulbs, and if the bulbs are lit, avoid contact with liquids. The bulb should only be operated when installed in a headlamp.
If a bulb becomes damaged or cracked, replace it immediately and carefully dispose of the damaged bulb.
Keep bulbs **out of the reach of children.**
- Wear eye protection when changing the bulb. Allow the bulb to cool before handling.

(Cabriolet models)

	Light bulb	Wattage
A	Luggage compartment light	5
B	1 Turn-signal light	21
	2 Taillight/Stop light	5/21
	3 Taillight	5
	4 Rear fog light	21
	5 Back up light	21
C	License plate light	5

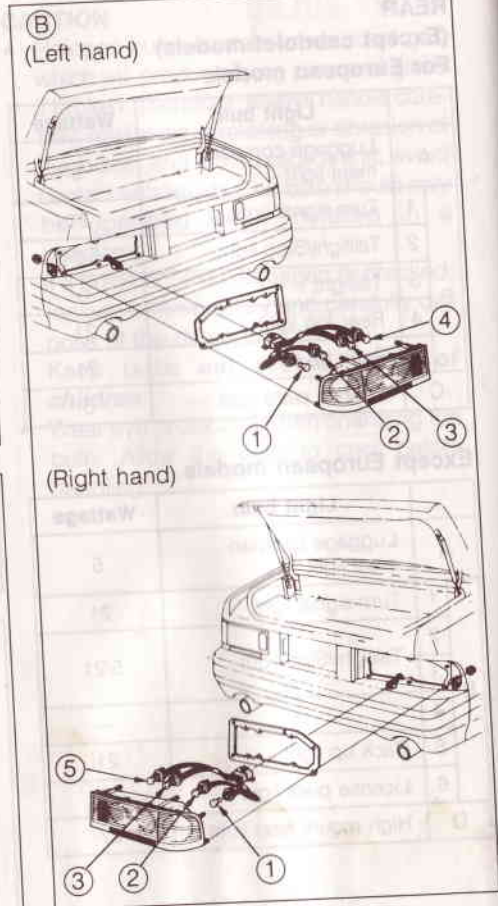
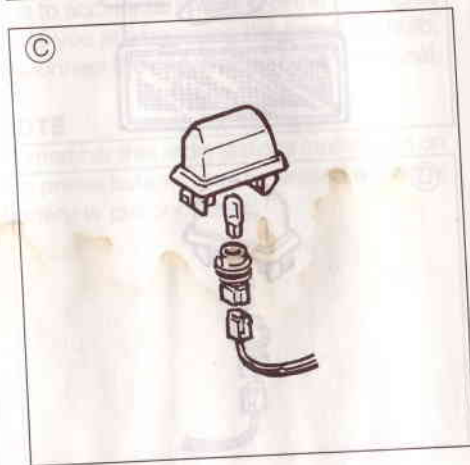
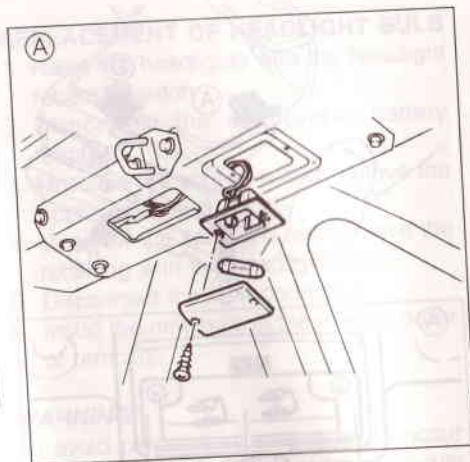
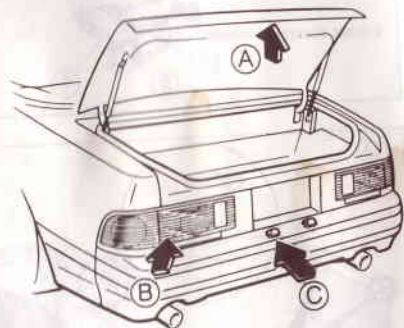

MINOR TROUBLESHOOTING GUIDE

The following procedures may help if any of the problems listed below should occur.

These suggestions are intended only as emergency measures. If you are in doubt whether the problem is fully corrected, see your Authorized Mazda Dealer as soon as possible. Minor problems may lead to serious ones, if neglected.

ENGINE WILL NOT START

If the engine will not turn over, inspect these items:

1. Ignition switch.
2. Fuses, including main fuse block in the engine compartment.
3. Battery and connections.
4. Cable connections to starter and solenoid.
5. Automatic transmission selector, to see if it is in N or P position.

If the engine turns over, inspect these items:

1. Fuel gauge, to see that the tank is not empty.
2. Ignition system-ignition leads, coil.
3. Spark plugs.
4. Fuel system and air flow system.

ENGINE STARTS, BUT ...

If the oil pressure warning light comes on, inspect these items:

1. Engine oil level.
2. Electric circuit and switch.

If the alternator warning light comes on, inspect these items:

1. Drive belt, broken, or needs adjustment tension and condition.
2. Alternator.
3. Battery and connections.

If stalling occurs while idling, inspect these items:

1. Idle speed and idle mixture adjustment (adjustment by an Authorized Mazda Dealer).
2. Spark plugs.
3. Fuel system and air flow system.
4. Compression pressure.

If idling is rough, inspect these items:

1. Air cleaner element.
2. Spark plugs.
3. Idle speed and idle mixture adjustment (adjustment by an Authorized Mazda Dealer).

If acceleration is poor, inspect these items:

1. Ignition system including spark plugs.
2. Air cleaner element.
3. Fuel system and air flow system.
4. Compression pressure.

If overheating occurs, inspect these items:

1. Radiator coolant level.
2. Restriction of airflow through radiator.
3. Drive belt tension and condition.
4. Engine oil level.
5. Thermostat.
6. Ignition timing.

If a flat spot occurs when accelerating, inspect these items:

1. Fuel system and filter.
2. Air cleaner element.

If full engine power is not obtained, inspect these items:

1. Air cleaner element and fuel filter.
2. Spark plugs and ignition system.
3. Fuel system and air flow system.

BRAKES DO NOT WORK PROPERLY

1. After driving through deep water, apply the brakes gently while moving and hold them there until normal braking action returns.

WARNING!

Brakes may pull vehicle to either side.

2. Check the brake system warning light for indication of fluid leaks in the system.
3. If the brake pedal resistance is spongy, have the hydraulic system inspected by your Authorized Mazda Dealer.
4. Let brakes cool after heavy use, such as in mountain driving.
5. If braking action is uneven (pulls to either side), check tire pressures and brake lining/pads.

STEERING PROBLEMS ...

If the vehicle steers hard, inspect these items:

1. Tire pressures.
2. Front wheel alignment.

If the vehicle wanders or pulls to either side, inspect these items:

1. Tire pressures.
2. Wheel balance.
3. Steering system preload.
4. Overloading or uneven loading of vehicle.
5. Front wheel alignment.

ELECTRICAL SYSTEM PROBLEMS ...

If a light does not come on, inspect these items.

1. Bulb and fuse.
2. Terminal connections and system ground.

7. SPECIFICATIONS

97C8 0010E

MEASUREMENT

Overall length	4,315mm (169.9 in)
Overall width	1,690mm (66.5 in)
Overall height	1,265mm (49.8 in)
Front tread	1,450mm (57.1 in)
Rear tread	1,440mm (56.7 in)
Wheel base	2,430mm (95.7 in)

97E8 0020E

ENGINE

Engine type		Rotary engine	
Displacement cc (cu in)		654 x 2 (40.0 x 2)	
Compression ratio		Except European models (Non-turbo models)	9.4
		For European models (Turbo models)	9.0
Idle speed		750 rpm in neutral	
Ignition timing (at idle)	Trailing	20° ATDC in neutral	
	Leading	5° ATDC in neutral	
Oil capacity	Full	5.8 liters (6.1 US qt, 5.1 Imp qt)	
	Oil pan	4.4 liters (4.7 US qt, 3.9 Imp qt)	
Oil filter capacity		0.17 liter (0.18 US qt, 0.15 Imp qt)	

97E8 0030E

FUEL SYSTEM

Tank capacity	Except European models (Non-turbo models)	70 liters (18.5 US gal, 15.4 Imp gal)
	For European models (Turbo models)	72 liters (19.0 US gal, 15.8 Imp gal)

97E8 0050E

COOLING SYSTEM

Coolant capacity	8.7 liters (9.2 US gal, 7.7 Imp gal)
------------------	--------------------------------------

97E8 0055E

ELECTRICAL SYSTEM

Battery	50D 20L or 65D 23LMF
Alternator	12V — 80 amp
Starter	12V — 1.2 kw

97E8-0060E

TRANSMISSION

Item	Models	Except European models (Non-turbo models)	For European models (Turbo models)
	Gear ratio	1st	3.475
2nd		2.002	2.015
3rd		1.366	1.391
4th		1.000	1.000
5th		0.756	0.719
	Rev.	3.493	3.288
Oil capacity		2.5 liters (2.6 US qt, 2.2 Imp qt)	

97E8-0070E

REAR AXLE

Models Item	Except European models (Non-turbo models)	For European models (Turbo models)
Final gear ratio	4.300	4.100
Oil capacity	1.3 liters (1.4 US qt, 1.1 Imp qt)	1.4 liters (1.5 US qt, 1.2 Imp qt)

97C8 0080E

STEERING

Steering type	Rack and pinion
Min. turning radius	5.3m (17.4 ft)

97E8-0090E

BRAKE (with power assist unit)

Brake type	Ventilated disc
------------	-----------------

97E8-0100E

SUSPENSION

Suspension type	Front	Strut with coil springs
	Rear	Multi-link, Semi-trailing

7. SPECIFICATIONS**MEASUREMENT**

Wheel base	2.400mm (95.1")
Rear wheel	1.400mm (55.1")
Front wheel	1.400mm (55.1")
Front track	1.400mm (55.1")
Rear track	1.400mm (55.1")
Overall length	4.315mm (169.5")
Overall width	1.800mm (70.9")
Overall height	1.500mm (59.1")

ENGINE

Engine type	Four-cylinder
Displacement (cc)	654 x 71.0
Compression ratio	10.0
Oil capacity	3.5 liters (3.7 US qt, 3.1 Imp qt)
Idle speed (rpm)	750
Idle timing (in. (mm))	0.0 (0.0)
Overhaul interval (km)	100,000 (62,000)
Oil filter capacity (liters)	3.5 (3.7 US qt, 3.1 Imp qt)
Oil filter capacity (US qt)	3.7
Oil filter capacity (Imp qt)	3.1

VEHICLE IDENTIFICATION

1. ENGINE NUMBER
2. CHASSIS NUMBER
3. MODEL PLATE
4. TIRE PRESSURE LABEL
5. OIL LABEL

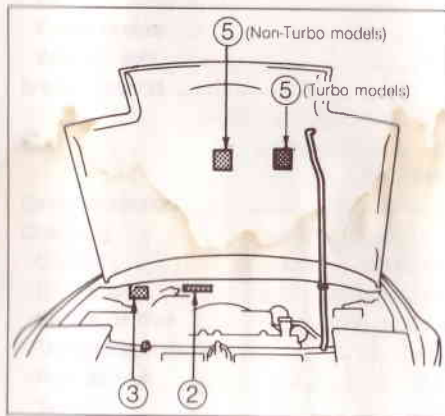
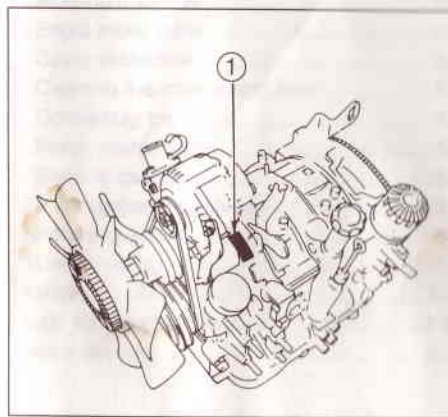
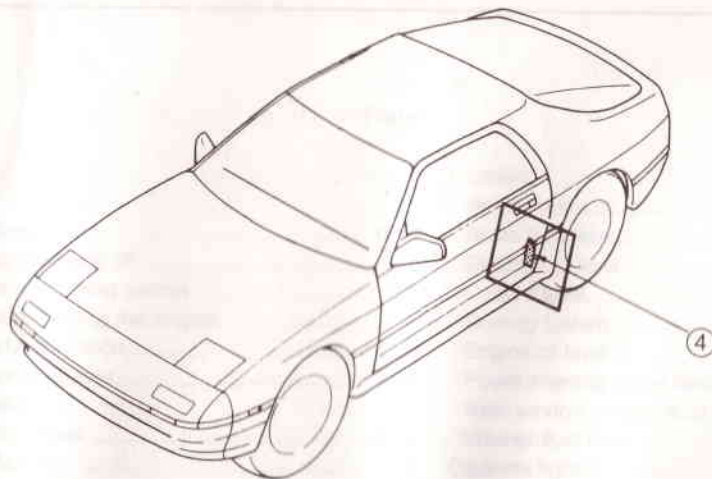

VEHICLE IDENTIFICATION

ENGINE NUMBER

CHASSIS NUMBER

MODEL PLATE

TIRE PRESSURE LABEL

OIL LABEL

YEAR LABEL

Year	Model	Engine	Chassis	Model Plate	Tire Pressure	Oil Label
1988	1988	1988	1988	1988	1988	1988
1989	1989	1989	1989	1989	1989	1989
1990	1990	1990	1990	1990	1990	1990
1991	1991	1991	1991	1991	1991	1991
1992	1992	1992	1992	1992	1992	1992
1993	1993	1993	1993	1993	1993	1993
1994	1994	1994	1994	1994	1994	1994
1995	1995	1995	1995	1995	1995	1995
1996	1996	1996	1996	1996	1996	1996
1997	1997	1997	1997	1997	1997	1997
1998	1998	1998	1998	1998	1998	1998
1999	1999	1999	1999	1999	1999	1999
2000	2000	2000	2000	2000	2000	2000
2001	2001	2001	2001	2001	2001	2001
2002	2002	2002	2002	2002	2002	2002
2003	2003	2003	2003	2003	2003	2003
2004	2004	2004	2004	2004	2004	2004
2005	2005	2005	2005	2005	2005	2005
2006	2006	2006	2006	2006	2006	2006
2007	2007	2007	2007	2007	2007	2007
2008	2008	2008	2008	2008	2008	2008
2009	2009	2009	2009	2009	2009	2009
2010	2010	2010	2010	2010	2010	2010
2011	2011	2011	2011	2011	2011	2011
2012	2012	2012	2012	2012	2012	2012
2013	2013	2013	2013	2013	2013	2013
2014	2014	2014	2014	2014	2014	2014
2015	2015	2015	2015	2015	2015	2015
2016	2016	2016	2016	2016	2016	2016
2017	2017	2017	2017	2017	2017	2017
2018	2018	2018	2018	2018	2018	2018
2019	2019	2019	2019	2019	2019	2019
2020	2020	2020	2020	2020	2020	2020
2021	2021	2021	2021	2021	2021	2021
2022	2022	2022	2022	2022	2022	2022

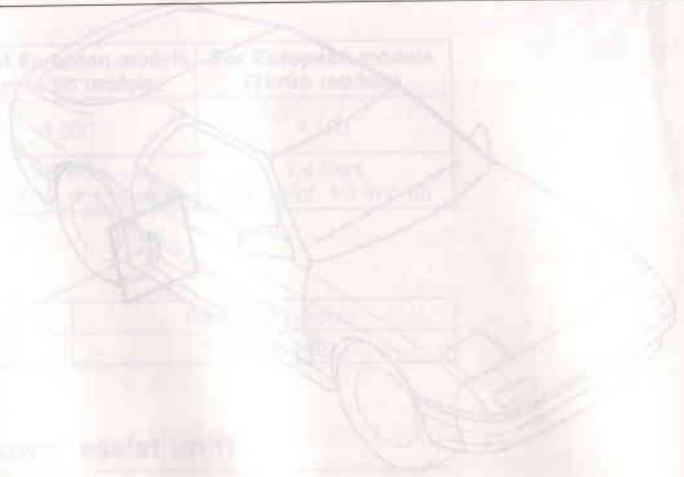

TAKE (with your hand)

MEASUREMENTS

1. Wheelbase

2. Overall length

3. Overall width

4. Overall height

5. Ground clearance

6. Wheel diameter

7. Tire width

8. Tire height

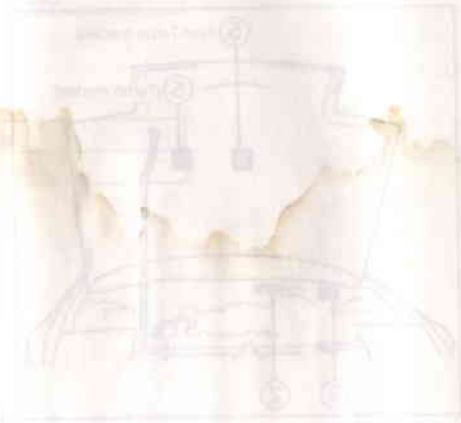

8. INDEX

	Page
A	
Air cleaner.....	6-25
Air conditioner.....	3-35
Drive belt.....	6-27
Alternator	
Drive belt.....	6-26
Warning light.....	3-23
Aluminum wheels.....	4-19
Anti-theft steering column lock.....	3-2
Appearance care	
Aluminum wheels.....	5-4
Bright metal parts.....	5-4
Cavity protection.....	5-5
Cleaning the interior and floor.....	5-3
Convertible top.....	5-6
Finish maintenance.....	5-1
General caution.....	5-5
Paint damage touch-up.....	5-5
Polishing and waxing.....	5-4
Undercoating.....	5-5
Ashtray.....	3-28
Auto adjusting suspension.....	3-25
Audio system.....	3-36

B

Battery.....	6-28
Before driving off.....	2-1
Before entering vehicle.....	2-1
Before starting the engine.....	3-3
Body lubrication.....	6-23
Bonnet release.....	3-24
Brake	
Fluid level.....	6-16
Parking.....	3-62
Pedal.....	3-62
Power brakes.....	3-63
Warning light.....	3-22
Break-in period.....	2-1
C	
Cavity protection.....	5-5
Changing	
Coolant.....	6-24
Engine oil.....	6-21
Engine oil filter.....	6-21
Transmission oil.....	6-22
Rear axle oil.....	6-23
Tire.....	4-10

Page

Checking

Belt tension.....	6-26
Brake fluid level.....	6-16
Clutch fluid level.....	6-16
Coolant level.....	6-15
Cooling system.....	6-24
Engine oil level.....	6-13
Power steering pump fluid level.....	6-22
Rear window washer fluid level.....	6-15
Washer fluid level.....	6-14
Cigarette lighter.....	3-28
Cleaning the interior and floor.....	5-3
Clock.....	3-27
Cooling system.....	6-24
Checking.....	6-24
Cruise control.....	3-6

D

Day-night rearview mirror.....	2-16
Digital electric clock.....	3-27
Door lock cylinder illumination.....	2-4
Door locks.....	2-3
Power door lock.....	2-4
Door ajar warning light.....	2-5

	Page
E	
Economical operation.....	3-5
Emergency starting.....	4-1
Jump-starting with auxiliary battery.....	4-1
Push starting.....	4-3
Engine compartment.....	6-12
Engine exhaust gas caution.....	1-5
Engine oil	
Changing.....	6-21
Level.....	6-13
Pressure gauge.....	3-19
Warning light/Buzzer.....	3-23
Engine oil filter	
Changing.....	6-21
F	
Floor controls.....	3-62
Folding rear seat.....	2-8
Foot rest.....	3-51
Front seats.....	2-6
Rear seat access.....	2-8
Seat reclining adjustment.....	2-7
Seat slide adjustment.....	2-7
Front side turn light.....	6-31
Front turn signal light.....	6-31
Fuel gauge.....	3-19
Fuel recommendation.....	1-4

Fuel tank.....	2-13
Fuel tank filler cap.....	2-13
Fuel filler lid.....	2-13
Fuses.....	6-29
G	
Gauge	
Boost meter.....	3-20
Fuel gauge.....	3-19
Oil pressure gauge.....	3-19
Voltmeter.....	3-20
Water temperature gauge.....	3-18
General caution.....	5-5
Glove box.....	3-28
H	
Hazardous driving conditions.....	4-5
Hazard warning flasher.....	4-1
Headlight	
Headlights.....	6-31
Headlight retractor.....	3-11
High beam indicator light.....	3-23
Leveling switch.....	3-9
Lighting control.....	3-8
Switch.....	3-8
Washer.....	3-14

Heating and defrosting system.....	3-30
Control panel and switch.....	3-30
Fan speed control.....	3-30
Heater controls.....	3-31
Horn control.....	3-26
I	
Ignition switch.....	3-2
Illumination.....	3-2
Important preliminary information.....	1-1
Instruments and controls.....	3-1
Instrument panel.....	3-17
Instrument panel illumination	
control.....	3-15
Interior light and map light.....	3-49,6-32

J	
Jack and jack handle.....	4-8
Jacking instructions.....	4-10
Jump-starting with an auxiliary battery.....	4-1

K	
Key.....	2-3

L

License plate light	6-33,6-34
Light bulbs	6-31
Lighting control	3-8
Lights reminder buzzer	3-8
Lock	
Anti-theft steering column lock	3-2
Door lock cylinder illumination	2-4
Door locks	2-3
Low fuel level warning light	3-23
Luggage compartment light	3-49,6-33,6-34
Luggage straps	2-16

M

Maintenance and warranties	1-3
Maintenance service precautions	6-11
Transmission	
Oil	6-22
Operation	3-4
Shift point recommendations	3-5
Map light	3-48,6-32
Minor troubleshooting guide	6-35
Mirror	
Day-night rearview	2-16
Mobile two-way radio system	1-5

O

Odometer	3-17
One-touch mist	3-13
Operating caution	1-5

P

Paint damage touch-up	5-5
Parking brake	3-62
Parking light	6-31
Polishing and waxing	5-4
Power brakes	3-63
Power door locks	2-4
Power outside rearview mirror	2-15
Power sliding sunroof	3-50
Power steering pump	
Drive belt	6-28
Fluid level	6-22
Power windows	2-5
Push starting	4-3

R

Rear combination light	6-33,6-34
Rear fog light	3-11
Rear glass hatch	2-11
Remote rear glass hatch release	2-12
Warning light	2-12,3-21
Rear window	
Defroster	3-15
Washer	3-16
Fluid level	6-15
Wiper	3-16
Recommended lubricants	6-19
Recommended SAE viscosity numbers	6-20
Refueling	2-13
Registering your vehicle	
in a foreign country	1-4
Replacement wheels	4-18
Rocking the vehicle	4-5
Routine service	6-10

S

Scheduled maintenance service	6-2
Seat belt restraint system	2-9
Proper use and care	2-10
Seats	2-6
Side air vent operation	3-29
Sliding sunroof	3-50
Sound warning system	2-2
Spare tire	4-6
Spark plugs	6-25
Specifications	7-1
Speedometer	3-18
Starting the engine	3-3
Steering column lock	3-2
Steering linkage	6-23
Steering wheel	2-9
Suggestions for economical operation	3-5

Page

T

Tachometer	3-20
Temporary spare tire	4-9
Tilt steering wheel	2-9
Tire	
Care	4-17
Changing	4-10
Checking tire inflation pressure	6-18
Directional tires	4-16
Rotation	4-17
Snow tires	4-17
Temporary spare tire	4-9
Usage	4-18
Wear	4-18
Tips on starting	3-3
Towing	4-3
Transmission oil	6-22
Tripmeter	3-18
Tripmeter reset knob	3-18
Turn and lane-change signals	3-10
Turn signal/Hazard warning flasher indicator light	3-18

Page

U

Undercoating	5-5
Use of aluminum wheel	4-19
Use of directional tires	4-16
Use of snow tires	4-17

V

Vehicle identifications	7-3
Voltmeter	3-20

W

Warning and indicator lights	3-21
Alternator	3-23
Anti-lock brake	3-21
Brake system	3-22
Coolant level	3-23
Door ajar	2-5,3-21
Engine oil level	3-23
Hazard warning flasher	3-21
Headlight high beam	3-23
Headlight washer fluid low level	3-21
Low fuel level	3-23
Rear fog light	3-23
Rear glass hatch ajar	2-12,3-21
Washer fluid low level	3-22

Page



