

DO NOT CHASE THREADS
AFTER MILLING THROTTLE SHAFT.
OWNER WILL CLEAN & DEBUR THREADS.

M3 X 0.5 THREAD
(TYP OF 4)

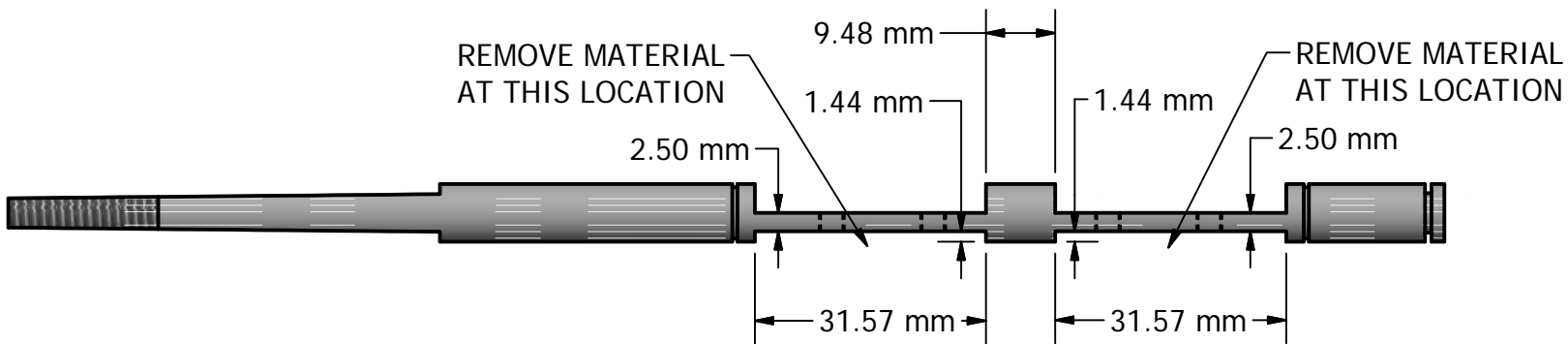

TOP VIEW
SCALE 1 : 1



SIDE VIEW
SCALE 1 : 1

DO NOT CHASE THREADS
AFTER MILLING THROTTLE SHAFT.
OWNER WILL CLEAN AND DEBUR THREADS.

M4 X 0.7 THREAD
(TYP OF 4)



TOP VIEW
SCALE 1 : 1

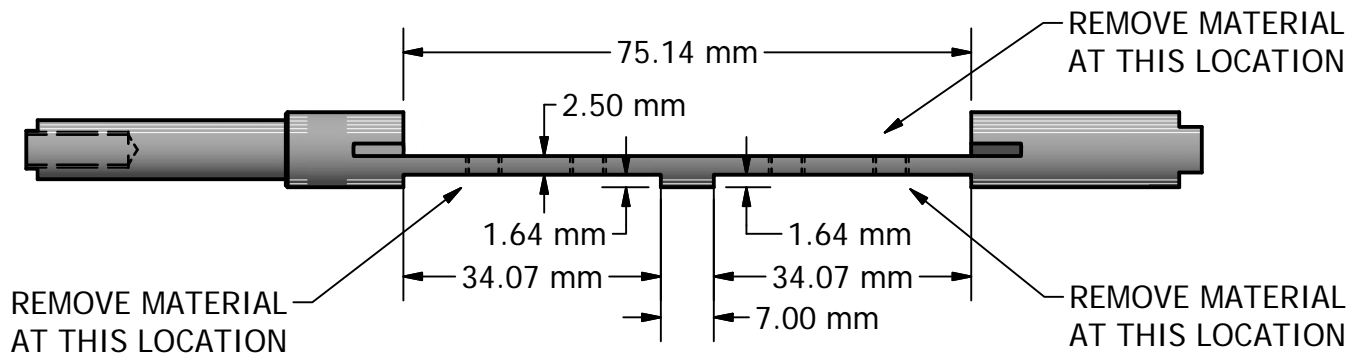

SIDE VIEW
SCALE 1 : 1