



DO NOT CHASE THREADS  
AFTER MILLING THROTTLE SHAFT.  
OWNER WILL CLEAN & DEBUR THREADS.

M3 X 0.5 THREAD  
(TYP OF 4)



TOP VIEW  
SCALE 1 : 1

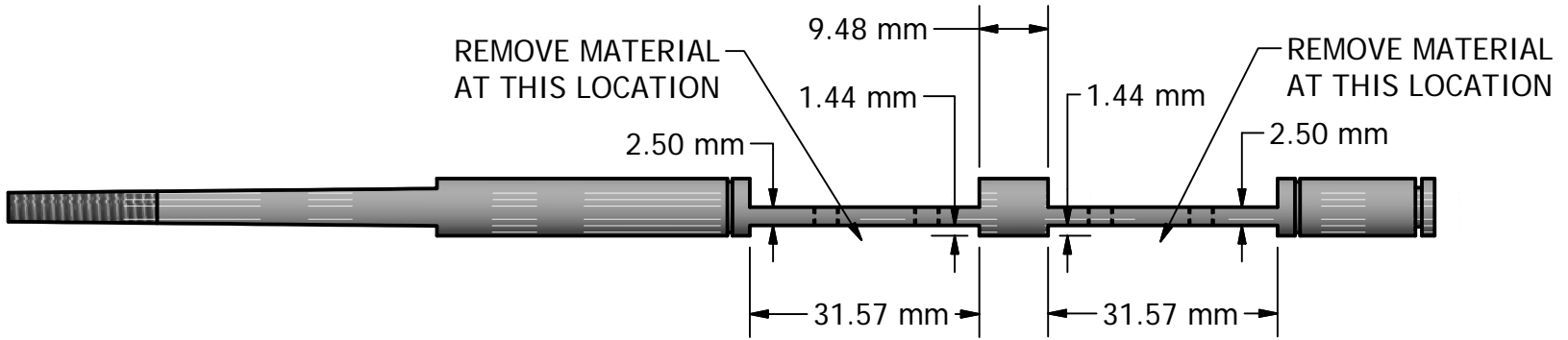

SIDE VIEW  
SCALE 1 : 1

DO NOT CHASE THREADS  
AFTER MILLING THROTTLE SHAFT.  
OWNER WILL CLEAN AND DEBUR THREADS.

M4 X 0.7 THREAD  
(TYP OF 4)



TOP VIEW  
SCALE 1 : 1

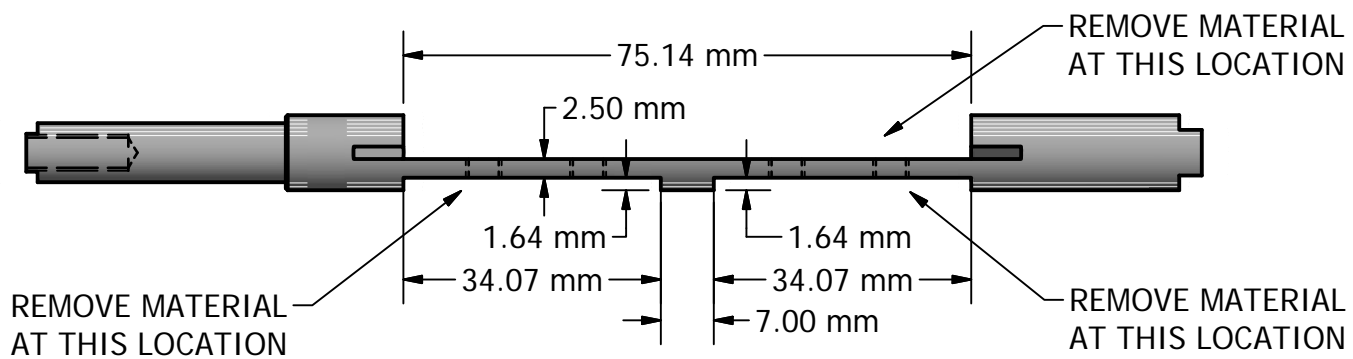

SIDE VIEW  
SCALE 1 : 1